

Issued 1994-08
Revised 2003-12

Superseding J1939-71 AUG2002

Vehicle Application Layer — J1939-71 (through December 2001)***Foreword***

This document has also changed to comply with the SAE Technical Standards Board format. Definitions have changed to Section 3 and Abbreviations to Section 4. All other section numbers have changed accordingly. This series of SAE Recommended Practices has been developed by the SAE Truck and Bus Control and Communications Network Subcommittee of the SAE Truck and Bus Electrical and Electronics Committee. The objectives of the subcommittee are to develop information reports, recommended practices, and standards concerned with the requirements design and usage of devices which transmit electronic signals and control information among vehicle components. The usage of these documents is not limited to truck and bus applications; other applications may be accommodated with immediate support being provided for construction and agricultural equipment, and stationary power systems. These documents are intended as a guide toward standard practice and are subject to change as to keep pace with experience and technical advances.

New parameters and parameter groups are reviewed and discussed by the Subcommittee on a regular basis. This document reflects all changes and additions approved and balloted through December 2001.

SAE Technical Standards Board Rules provide that: "This report is published by SAE to advance the state of technical and engineering sciences. The use of this report is entirely voluntary, and its applicability and suitability for any particular use, including any patent infringement arising therefrom, is the sole responsibility of the user."

SAE reviews each technical report at least every five years at which time it may be reaffirmed, revised, or cancelled. SAE invites your written comments and suggestions.

Copyright © 2003 SAE International

All rights reserved. No part of this publication may be reproduced, stored in a retrieval system or transmitted, in any form or by any means, electronic, mechanical, photocopying, recording, or otherwise, without the prior written permission of SAE.

TO PLACE A DOCUMENT ORDER: Tel: 877-606-7323 (inside USA and Canada)
Tel: 724-776-4970 (outside USA)
Fax: 724-776-0790
Email: custsvc@sae.org
SAE WEB ADDRESS: <http://www.sae.org>

Vehicle Application Layer - J1939-71 (through December 2001)

Table Of Contents

1.	Scope	22
2.	References	22
2.1.	Applicable Documents	22
2.1.1.	SAE Publications	22
2.1.2.	ISO Publications	22
3.	Definitions	22
4.	Abbreviations	22
5.	Technical Requirements	22
5.1.	General Guidelines	23
5.1.1.	Signal Characterization	23
5.1.2.	Message Format	23
5.1.3.	ISO Latin 1 Character Set	23
5.1.4.	Parameter Ranges	24
5.1.5.	Assignment of Ranges to new Parameters	25
5.1.6.	Adding Parameters to Parameter Groups	28
5.1.7.	Transmission Repetition Rates (Update Rates)	28
5.1.8.	Naming Convention For Engine Parameters	29
5.1.9.	Application Notes	29
5.2.	Parameter Definitions	29
spn16 -	Fuel Filter (Suction Side) Differential Pressure (see also SPN 1382)	30
spn21 -	Engine ECU Temperature (use SPN 1136)	30
spn22 -	Extended Crankcase Blow-by Pressure	30
spn39 -	Tire Pressure Check Interval	31
spn46 -	Pneumatic Supply Pressure	31
spn51 -	Throttle Position	31
spn52 -	Engine Intercooler Temperature	31
spn53 -	Transmission Synchronizer Clutch Value	31
spn54 -	Transmission Synchronizer Brake Value	31
spn59 -	Shift Finger Gear Position	32
spn60 -	Shift Finger Rail Position	32
spn69 -	Two Speed Axle Switch	32
spn70 -	Parking Brake Switch	32
spn72 -	Blower Bypass Valve Position	32
spn73 -	Auxiliary Pump Pressure	33
spn74 -	Maximum Vehicle Speed Limit	33
spn75 -	Steering Axle Temperature	33
spn79 -	Road Surface Temperature	33
spn80 -	Washer Fluid Level	33
spn81 -	Particulate Trap Inlet Pressure	34
spn82 -	Air Start Pressure	34
spn84 -	Wheel-Based Vehicle Speed	34
spn86 -	Cruise Control Set Speed	34
spn87 -	Cruise Control High Set Limit Speed	34
spn88 -	Cruise Control Low Set Limit Speed	34
spn90 -	Power Takeoff Oil Temperature	35
spn91 -	Accelerator Pedal Position 1	35
spn92 -	Percent Load At Current Speed	35
spn94 -	Fuel Delivery Pressure	35
spn95 -	Fuel Filter Differential Pressure	36
spn96 -	Fuel Level	36
spn97 -	Water In Fuel Indicator	36
spn98 -	Engine Oil Level	36
spn99 -	Engine Oil Filter Differential Pressure	36
spn100 -	Engine Oil Pressure	37
spn101 -	Crankcase Pressure	37
spn102 -	Boost Pressure	37

spn103 -	Turbocharger 1 Speed	37
spn104 -	Turbocharger Lube Oil Pressure 1	37
spn105 -	Intake Manifold 1 Temperature	38
spn106 -	Air Inlet Pressure	38
spn107 -	Air Filter 1 Differential Pressure	38
spn108 -	Barometric Pressure	38
spn109 -	Coolant Pressure	38
spn110 -	Engine Coolant Temperature	39
spn111 -	Coolant Level	39
spn112 -	Coolant Filter Differential Pressure	39
spn114 -	Net Battery Current	39
spn115 -	Alternator Current	39
spn116 -	Brake Application Pressure	39
spn117 -	Brake Primary Pressure	40
spn118 -	Brake Secondary Pressure	40
spn119 -	Hydraulic Retarder Pressure	40
spn120 -	Hydraulic Retarder Oil Temperature	40
spn123 -	Clutch Pressure	40
spn124 -	Transmission Oil Level	41
spn126 -	Transmission Filter Differential Pressure	41
spn127 -	Transmission Oil Pressure	41
spn129 -	Injector Metering Rail 2 Pressure (duplicate, use 1349)	41
spn132 -	Inlet Air Mass Flow Rate	41
spn136 -	Auxiliary Vacuum Pressure Reading	42
spn137 -	Auxiliary Gage Pressure Reading 1	42
spn138 -	Auxiliary Absolute Pressure Reading	42
spn141 -	Trailer, Tag Or Push Channel Tire Pressure Target	42
spn142 -	Drive Channel Tire Pressure Target	42
spn143 -	Steer Channel Tire Pressure Target	43
spn144 -	Trailer, Tag Or Push Channel Tire Pressure	43
spn145 -	Drive Channel Tire Pressure	43
spn146 -	Steel Channel Tire Pressure	43
spn156 -	Injector Timing Rail 1 Pressure	43
spn157 -	Injector Metering Rail 1 Pressure	44
spn158 -	Battery Potential (Voltage), Switched	44
spn159 -	Gas Supply Pressure	44
spn160 -	Main Shaft Speed	44
spn161 -	Input Shaft Speed	44
spn162 -	Transmission Requested Range	45
spn163 -	Transmission Current Range	45
spn164 -	Injection Control Pressure	45
spn165 -	Compass Bearing	45
spn166 -	Rated Engine Power	46
spn167 -	Alternator Potential (Voltage)	46
spn168 -	Electrical Potential (Voltage)	46
spn169 -	Cargo Ambient Temperature	46
spn170 -	Cab Interior Temperature	46
spn171 -	Ambient Air Temperature	46
spn172 -	Air Inlet Temperature	47
spn173 -	Exhaust Gas Temperature	47
spn174 -	Fuel Temperature	47
spn175 -	Engine Oil Temperature 1	47
spn176 -	Turbo Oil Temperature	47
spn177 -	Transmission Oil Temperature	48
spn180 -	Trailer Weight	48
spn181 -	Cargo Weight	48
spn182 -	Trip Fuel	48
spn183 -	Fuel Rate	48
spn184 -	Instantaneous Fuel Economy	49
spn185 -	Average Fuel Economy	49
spn186 -	Power Takeoff Speed	49
spn187 -	Power Takeoff Set Speed	49
spn188 -	Engine Speed At Idle, Point 1 (Engine Configuration)	49
spn189 -	Rated Engine Speed	49

spn190 -	Engine Speed	50
spn191 -	Output Shaft Speed	50
spn233 -	Unit Number (Power Unit)	50
spn234 -	Software Identification	50
spn235 -	Total Idle Hours	51
spn236 -	Total Idle Fuel Used	51
spn237 -	Vehicle Identification Number	51
spn241 -	Tire Pressure	51
spn242 -	Tire Temperature	51
spn244 -	Trip Distance	51
spn245 -	Total Vehicle Distance	52
spn246 -	Total Vehicle Hours	52
spn247 -	Total Engine Hours	52
spn248 -	Total Power Takeoff Hours	52
spn249 -	Total Engine Revolutions	52
spn250 -	Total Fuel Used	53
spn411 -	Exhaust Gas Recirculation Differential Pressure	53
spn412 -	Exhaust Gas Recirculation Temperature	53
spn441 -	Auxiliary Temperature 1	53
spn442 -	Auxiliary Temperature 2	53
spn444 -	Battery 2 Potential (Voltage)	54
spn512 -	Driver's Demand Engine - Percent Torque	54
spn513 -	Actual Engine - Percent Torque	55
spn514 -	Nominal Friction - Percent Torque	56
spn515 -	Engine's Desired Operating Speed	56
spn516 -	Ground-Based Vehicle Speed	56
spn517 -	Navigation-Based Vehicle Speed	56
spn518 -	Requested Torque/Torque Limit	57
spn519 -	Engine's Desired Operating Speed Asymmetry Adjustment	60
spn520 -	Actual Retarder - Percent Torque	61
spn521 -	Brake Pedal Position	61
spn522 -	Percent Clutch Slip	62
spn523 -	Current Gear	62
spn524 -	Selected Gear	62
spn525 -	Requested Gear	62
spn526 -	Actual Gear Ratio	63
spn527 -	Cruise Control States	63
spn528 -	Engine Speed At Point 2 (Engine Configuration)	64
spn529 -	Engine Speed At Point 3 (Engine Configuration)	64
spn530 -	Engine Speed At Point 4 (Engine Configuration)	65
spn531 -	Engine Speed At Point 5 (Engine Configuration)	65
spn532 -	Engine Speed At High Idle, Point 6 (Engine Configuration)	65
spn533 -	Maximum Momentary Engine Override Speed, Point 7 (Engine Configuration)	65
spn534 -	Maximum Momentary Override Time Limit (Engine Configuration)	66
spn535 -	Requested Speed Control Range Lower Limit (Engine Configuration)	66
spn536 -	Requested Speed Control Range Upper Limit (Engine Configuration)	66
spn537 -	Requested Torque Control Range Lower Limit (Engine Configuration)	66
spn538 -	Requested Torque Control Range Upper Limit (Engine Configuration)	66
spn539 -	Percent Torque At Idle, Point 1 (Engine Configuration)	67
spn540 -	Percent Torque At Point 2 (Engine Configuration)	67
spn541 -	Percent Torque At Point 3 (Engine Configuration)	67
spn542 -	Percent Torque At Point 4 (Engine Configuration)	68
spn543 -	Percent Torque At Point 5 (Engine Configuration)	68
spn544 -	Reference Engine Torque (Engine Configuration)	68
spn545 -	Gain (Kp) Of The Endspeer Governor (Engine Configuration)	68
spn546 -	Retarder Speed At Idle, Point 1 (Retarder Configuration)	69
spn547 -	Retarder Speed At Peak Torque, Point 5 (Retarder Configuration)	69
spn548 -	Maximum Retarder Speed, Point 2 (Retarder Configuration)	69
spn549 -	Retarder Speed At Point 3 (Retarder Configuration)	69
spn550 -	Retarder Speed At Point 4 (Retarder Configuration)	69
spn551 -	Percent Torque At Idle, Point 1 (Retarder Configuration)	69
spn552 -	Percent Torque At Maximum Speed, Point 2 (Retarder Configuration)	70
spn553 -	Percent Torque At Point 3 (Retarder Configuration)	70
spn554 -	Percent Torque At Point 4 (Retarder Configuration)	70

spn555 -	Percent Torque At Peak Torque, Point 5 (Retarder Configuration)	70
spn556 -	Reference Retarder Torque (Retarder Configuration)	71
spn557 -	Retarder Control Method (Retarder Configuration)	71
spn558 -	Accelerator Pedal 1 Low Idle Switch	71
spn559 -	Accelerator Pedal Kickdown Switch	71
spn560 -	Driveline Engaged	72
spn561 -	ASR Engine Control Active	72
spn562 -	ASR Brake Control Active	72
spn563 -	Anti-Lock Braking (ABS) Active	72
spn564 -	Differential Lock State - Central	72
spn565 -	Differential Lock State - Central Front	73
spn566 -	Differential Lock State - Central Rear	73
spn567 -	Differential Lock State - Front Axle 1	73
spn568 -	Differential Lock State - Front Axle 2	74
spn569 -	Differential Lock State - Rear Axle 1	74
spn570 -	Differential Lock State - Rear Axle 2	74
spn571 -	Retarder Enable - Brake Assist Switch	74
spn572 -	Retarder Enable - Shift Assist Switch	74
spn573 -	Torque Converter Lockup Engaged	75
spn574 -	Shift In Process	75
spn575 -	ABS Off-road Switch	75
spn576 -	ASR Off-road Switch	75
spn577 -	ASR "Hill Holder" Switch	76
spn578 -	Drive Axle Temperature	76
spn579 -	Drive Axle Lift Air Pressure	76
spn580 -	Altitude	76
spn581 -	Transmission Gear Ratio	76
spn582 -	Axle Weight	76
spn583 -	Pitch	77
spn584 -	Latitude	77
spn585 -	Longitude	77
spn586 -	Make	77
spn587 -	Model	77
spn588 -	Serial Number	78
spn589 -	Alternator Speed	78
spn590 -	Idle Shutdown Timer State	78
spn591 -	Idle Shutdown Timer Function	79
spn592 -	Idle Shutdown Timer Override	79
spn593 -	Idle Shutdown has Shutdown Engine	80
spn594 -	Idle Shutdown Driver Alert Mode	80
spn595 -	Cruise Control Active	80
spn596 -	Cruise Control Enable Switch	80
spn597 -	Brake Switch	80
spn598 -	Clutch Switch	81
spn599 -	Cruise Control Set Switch	81
spn600 -	Cruise Control Coast (Decelerate) Switch	81
spn601 -	Cruise Control Resume Switch	81
spn602 -	Cruise Control Accelerate Switch	81
spn604 -	Transmission Neutral Switch	82
spn605 -	Refrigerant High Pressure Switch	82
spn606 -	Momentary Engine Overspeed Enable	82
spn607 -	Progressive Shift Disable	82
spn619 -	Parking Brake Actuator	82
spn681 -	Gear Shift Inhibit Request	83
spn682 -	Torque Converter Lockup Disable Request	83
spn683 -	Disengage Driveline Request	83
spn684 -	Requested Percent Clutch Slip	83
spn685 -	Disengage Differential Lock Request - Front Axle 1	83
spn686 -	Disengage Differential Lock Request - Front Axle 2	84
spn687 -	Disengage Differential Lock Request - Rear Axle 1	84
spn688 -	Disengage Differential Lock Request - Rear Axle 2	84
spn689 -	Disengage Differential Lock Request - Central	84
spn690 -	Disengage Differential Lock Request - Central Front	84
spn691 -	Disengage Differential Lock Request - Central Rear	85

spn692 -	ABS Offroad Switch Request	85
spn693 -	ASR Offroad Switch Request	85
spn694 -	ASR "Hill Holder" Switch Request	85
spn695 -	Override Control Mode	85
spn696 -	Requested Speed Control Conditions	87
spn701 -	Auxiliary I/O #01	88
spn702 -	Auxiliary I/O #02	88
spn703 -	Auxiliary I/O #03	88
spn704 -	Auxiliary I/O #04	88
spn705 -	Auxiliary I/O #05	89
spn706 -	Auxiliary I/O #06	89
spn707 -	Auxiliary I/O #07	89
spn708 -	Auxiliary I/O #08	89
spn709 -	Auxiliary I/O #09	89
spn710 -	Auxiliary I/O #10	90
spn711 -	Auxiliary I/O #11	90
spn712 -	Auxiliary I/O #12	90
spn713 -	Auxiliary I/O #13	90
spn714 -	Auxiliary I/O #14	90
spn715 -	Auxiliary I/O #15	90
spn716 -	Auxiliary I/O #16	91
spn740 -	Lockup Clutch Actuator	91
spn748 -	Transmission Output Retarder	91
spn767 -	Transmission Reverse Direction Switch	91
spn768 -	Range High Actuator	91
spn769 -	Range Low Actuator	91
spn770 -	Splitter Direct Actuator	92
spn771 -	Splitter Indirect Actuator	92
spn772 -	Shift Finger Rail Actuator 1	92
spn773 -	Shift Finger Gear Actuator 1	92
spn778 -	Transmission High Range Sense Switch	92
spn779 -	Transmission Low Range Sense Switch	93
spn780 -	Shift Finger Neutral Indicator	93
spn781 -	Shift Finger Engagement Indicator	93
spn782 -	Shift Finger Center Rail Indicator	93
spn783 -	Shift Finger Rail Actuator 2	93
spn784 -	Shift Finger Gear Actuator 2	93
spn786 -	Defuel Actuator	94
spn787 -	Inertia Brake Actuator	94
spn788 -	Clutch Actuator	94
spn875 -	Refrigerant Low Pressure Switch	94
spn897 -	Override Control Mode Priority	94
spn898 -	Requested Speed/Speed Limit	95
spn899 -	Engine Torque Mode	95
spn900 -	Retarder Torque Mode	96
spn901 -	Retarder Type	97
spn902 -	Retarder Location	98
spn903 -	Transmission Forward Direction Switch	99
spn904 -	Front Axle Speed	99
spn905 -	Relative Speed; Front Axle, Left Wheel	99
spn906 -	Relative Speed; Front Axle, Right Wheel	99
spn907 -	Relative Speed; Rear Axle #1, Left Wheel	99
spn908 -	Relative Speed; Rear Axle #1, Right Wheel	100
spn909 -	Relative Speed; Rear Axle #2, Left Wheel	100
spn910 -	Relative Speed; Rear Axle #2, Right Wheel	100
spn911 -	Service Component Identification	100
spn912 -	Service Component Identification	101
spn913 -	Service Component Identification	101
spn914 -	Service Distance	102
spn915 -	Service Delay/Calendar Time Based	102
spn916 -	Service Delay/Operational Time Based	102
spn917 -	High Resolution Total Vehicle Distance	102
spn918 -	High Resolution Trip Distance	103
spn927 -	Location	103

spn928 -	Axle Location	103
spn929 -	Tire Location	103
spn930 -	Drive Axle Location	103
spn957 -	Number of Forward Gear Ratios	104
spn958 -	Number of Reverse Gear Ratios	104
spn959 -	Seconds	104
spn960 -	Minutes	104
spn961 -	Hours	105
spn962 -	Day	105
spn963 -	Month	105
spn964 -	Year	105
spn965 -	Number of Software Identification Fields	105
spn966 -	Engine Test Mode Switch	106
spn967 -	Idle Decrement Switch	106
spn968 -	Idle Increment Switch	106
spn969 -	Remote Accelerator Enable Switch	106
spn970 -	Auxiliary Engine Shutdown Switch	106
spn971 -	Engine Derate Switch	107
spn972 -	Accelerator Interlock Switch	107
spn973 -	Engine Retarder Selection	107
spn974 -	Remote Accelerator Pedal Position	107
spn975 -	Estimated Percent Fan Speed	107
spn976 -	PTO State	108
spn977 -	Fan Drive State	109
spn978 -	Remote PTO Variable Speed Control Switch	110
spn979 -	Remote PTO Preprogrammed Speed Control Switch	110
spn980 -	PTO Enable Switch	110
spn981 -	PTO Accelerate Switch	111
spn982 -	PTO Resume Switch	111
spn983 -	PTO Coast/Decelerate Switch	111
spn984 -	PTO Set Switch	111
spn985 -	A/C High Pressure Fan Switch	111
spn986 -	Requested Percent Fan Speed	111
spn988 -	Trip Group 1	112
spn989 -	Trip Group 2 - Proprietary	112
spn990 -	Total Compression Brake Distance	112
spn991 -	Trip Compression Brake Distance	113
spn992 -	Trip Service Brake Distance	113
spn993 -	Trip Service Brake Applications	113
spn994 -	Trip Fan On Time	113
spn995 -	Trip Fan On Time Due to the Engine System	114
spn996 -	Trip Fan On Time Due to a Manual Switch	114
spn997 -	Trip Fan On Time Due to the A/C System	114
spn998 -	Trip Distance on VSL	114
spn999 -	Trip Gear Down Distance	114
spn1000 -	Trip Distance in Top Gear	115
spn1001 -	Trip Drive Fuel Used	115
spn1002 -	Trip PTO Moving Fuel Used	115
spn1003 -	Trip PTO Non-moving Fuel Used	115
spn1004 -	Trip Vehicle Idle Fuel Used	116
spn1005 -	Trip Cruise Fuel Used	116
spn1006 -	Trip Drive Fuel Economy	116
spn1007 -	Trip Drive Fuel Used (Gaseous)	116
spn1008 -	Trip PTO Moving Fuel Used (Gaseous)	117
spn1009 -	Trip PTO Non-moving Fuel Used (Gaseous)	117
spn1010 -	Trip Vehicle Idle Fuel Used (Gaseous)	117
spn1011 -	Trip Cruise Fuel Used (Gaseous)	117
spn1012 -	Trip Drive Fuel Economy (Gaseous)	118
spn1013 -	Trip Maximum Engine Speed	118
spn1014 -	Trip Average Engine Speed	118
spn1015 -	Trip Drive Average Load Factor	118
spn1016 -	Total Drive Average Load Factor	119
spn1017 -	Total Engine Cruise Time	119
spn1018 -	Trip Maximum Vehicle Speed	119

spn1019 -	Trip Cruise Distance	119
spn1020 -	Trip Number of Hot Shutdowns	120
spn1021 -	Trip Number of Idle Shutdowns	120
spn1022 -	Trip Number of Idle Shutdown Overrides	120
spn1023 -	Trip Sudden Decelerations	120
spn1024 -	Trip Time in VSL	120
spn1025 -	Trip Time in Top Gear	121
spn1026 -	Trip Time in Gear Down	121
spn1027 -	Trip Time in Derate by Engine	121
spn1028 -	Total Engine PTO Fuel Used	121
spn1029 -	Trip Average Fuel Rate	121
spn1030 -	Total Engine PTO Fuel Used (Gaseous)	122
spn1031 -	Trip Average Fuel Rate (Gaseous)	122
spn1032 -	Total ECU Distance	122
spn1033 -	Total ECU Run Time	122
spn1034 -	Trip Cruise Time	123
spn1035 -	Trip PTO Time	123
spn1036 -	Trip Engine Running Time	123
spn1037 -	Trip Idle Time	123
spn1038 -	Trip Air Compressor On Time	123
spn1039 -	Trip Fuel (Gaseous)	124
spn1040 -	Total Fuel Used (Gaseous)	124
spn1081 -	Wait to Start Lamp	124
spn1082 -	Engine Coolant Load Increase	124
spn1083 -	Auxiliary I/O Channel #1	124
spn1084 -	Auxiliary I/O Channel #2	125
spn1085 -	Intended Retarder Percent Torque	125
spn1086 -	Parking and/or Trailer Air Pressure	125
spn1087 -	Service Brake Air Pressure Circuit #1	126
spn1088 -	Service Brake Air Pressure Circuit #2	126
spn1089 -	Auxiliary Equipment Supply Pressure	126
spn1090 -	Air Suspension Supply Pressure	126
spn1091 -	Brake Application Pressure High Range, Front Axle, Left Wheel	126
spn1092 -	Brake Application Pressure High Range, Front Axle, Right Wheel	126
spn1093 -	Brake Application Pressure High Range, Rear Axle #1, Left Wheel	127
spn1094 -	Brake Application Pressure High Range, Rear Axle #1, Right Wheel	127
spn1095 -	Brake Application Pressure High Range, Rear Axle #2, Left Wheel	127
spn1096 -	Brake Application Pressure High Range, Rear Axle #2, Right Wheel	127
spn1097 -	Brake Application Pressure High Range, Rear Axle #3, Left Wheel	127
spn1098 -	Brake Application Pressure High Range, Rear Axle #3, Right Wheel	128
spn1099 -	Brake Lining Remaining, Front Axle, Left Wheel	128
spn1100 -	Brake Lining Remaining, Front Axle, Right Wheel	128
spn1101 -	Brake Lining Remaining, Rear Axle #1, Left Wheel	128
spn1102 -	Brake Lining Remaining, Rear Axle #1, Right Wheel	129
spn1103 -	Brake Lining Remaining, Rear Axle #2, Left Wheel	129
spn1104 -	Brake Lining Remaining, Rear Axle #2, Right Wheel	129
spn1105 -	Brake Lining Remaining, Rear Axle #3, Left Wheel	129
spn1106 -	Brake Lining Remaining, Rear Axle #3, Right Wheel	129
spn1107 -	Engine Protection System Timer State	130
spn1108 -	Engine Protection System Timer Override	130
spn1109 -	Engine Protection System Approaching Shutdown	131
spn1110 -	Engine Protection System has Shutdown Engine	131
spn1111 -	Engine Protection System Configuration	131
spn1113 -	Recommended Gear	131
spn1114 -	Lowest Possible Gear	131
spn1115 -	Highest Possible Gear	132
spn1116 -	Gaseous Fuel Correction Factor	132
spn1117 -	Desired Rated Exhaust Oxygen	132
spn1118 -	Desired Exhaust Oxygen	132
spn1119 -	Actual Exhaust Oxygen	132
spn1120 -	Articulation Angle	133
spn1121 -	EBS Brake Switch	133
spn1122 -	Alternator Bearing 1 Temperature	133
spn1123 -	Alternator Bearing 2 Temperature	133

spn1124 -	Alternator Winding 1 Temperature	133
spn1125 -	Alternator Winding 2 Temperature	134
spn1126 -	Alternator Winding 3 Temperature	134
spn1127 -	Turbocharger 1 Boost Pressure	134
spn1128 -	Turbocharger 2 Boost Pressure	134
spn1129 -	Turbocharger 3 Boost Pressure	134
spn1130 -	Turbocharger 4 Boost Pressure	135
spn1131 -	Intake Manifold 2 Temperature	135
spn1132 -	Intake Manifold 3 Temperature	135
spn1133 -	Intake Manifold 4 Temperature	135
spn1134 -	Engine Intercooler Thermostat Opening	136
spn1135 -	Engine Oil Temperature 2	136
spn1136 -	Engine ECU Temperature	136
spn1137 -	Exhaust Gas Port 1 Temperature	136
spn1138 -	Exhaust Gas Port 2 Temperature	136
spn1139 -	Exhaust Gas Port 3 Temperature	136
spn1140 -	Exhaust Gas Port 4 Temperature	137
spn1141 -	Exhaust Gas Port 5 Temperature	137
spn1142 -	Exhaust Gas Port 6 Temperature	137
spn1143 -	Exhaust Gas Port 7 Temperature	137
spn1144 -	Exhaust Gas Port 8 Temperature	137
spn1145 -	Exhaust Gas Port 9 Temperature	138
spn1146 -	Exhaust Gas Port 10 Temperature	138
spn1147 -	Exhaust Gas Port 11 Temperature	138
spn1148 -	Exhaust Gas Port 12 Temperature	138
spn1149 -	Exhaust Gas Port 13 Temperature	138
spn1150 -	Exhaust Gas Port 14 Temperature	138
spn1151 -	Exhaust Gas Port 15 Temperature	139
spn1152 -	Exhaust Gas Port 16 Temperature	139
spn1153 -	Exhaust Gas Port 17 Temperature	139
spn1154 -	Exhaust Gas Port 18 Temperature	139
spn1155 -	Exhaust Gas Port 19 Temperature	139
spn1156 -	Exhaust Gas Port 20 Temperature	140
spn1157 -	Main Bearing 1 Temperature	140
spn1158 -	Main Bearing 2 Temperature	140
spn1159 -	Main Bearing 3 Temperature	140
spn1160 -	Main Bearing 4 Temperature	140
spn1161 -	Main Bearing 5 Temperature	140
spn1162 -	Main Bearing 6 Temperature	141
spn1163 -	Main Bearing 7 Temperature	141
spn1164 -	Main Bearing 8 Temperature	141
spn1165 -	Main Bearing 9 Temperature	141
spn1166 -	Main Bearing 10 Temperature	141
spn1167 -	Main Bearing 11 Temperature	142
spn1168 -	Turbocharger Lube Oil Pressure 2	142
spn1169 -	Turbocharger 2 Speed	142
spn1170 -	Turbocharger 3 Speed	142
spn1171 -	Turbocharger 4 Speed	142
spn1172 -	Turbocharger 1 Compressor Inlet Temperature	143
spn1173 -	Turbocharger 2 Compressor Inlet Temperature	143
spn1174 -	Turbocharger 3 Compressor Inlet Temperature	143
spn1175 -	Turbocharger 4 Compressor Inlet Temperature	143
spn1176 -	Turbocharger 1 Compressor Inlet Pressure	143
spn1177 -	Turbocharger 2 Compressor Inlet Pressure	144
spn1178 -	Turbocharger 3 Compressor Inlet Pressure	144
spn1179 -	Turbocharger 4 Compressor Inlet Pressure	144
spn1180 -	Turbocharger 1 Turbine Inlet Temperature	144
spn1181 -	Turbocharger 2 Turbine Inlet Temperature	144
spn1182 -	Turbocharger 3 Turbine Inlet Temperature	145
spn1183 -	Turbocharger 4 Turbine Inlet Temperature	145
spn1184 -	Turbocharger 1 Turbine Outlet Temperature	145
spn1185 -	Turbocharger 2 Turbine Outlet Temperature	145
spn1186 -	Turbocharger 3 Turbine Outlet Temperature	145
spn1187 -	Turbocharger 4 Turbine Outlet Temperature	145

spn1188 -	Turbocharger 1 Wastegate Drive	146
spn1189 -	Turbocharger 2 Wastegate Drive	146
spn1190 -	Turbocharger 3 Wastegate Drive	146
spn1191 -	Turbocharger 4 Wastegate Drive	146
spn1192 -	Turbocharger Wastegate Actuator Control Air Pressure	147
spn1193 -	Engine Operation Time Since Rebuild	147
spn1194 -	Anti-theft Encryption Seed Present Indicator	147
spn1195 -	Anti-theft Password Valid Indicator	147
spn1196 -	Anti-theft Component Status States	147
spn1197 -	Anti-theft Modify Password States	148
spn1198 -	Anti-theft Random Number	148
spn1199 -	Anti-theft Encryption Indicator States	148
spn1200 -	Anti-theft Desired Exit Mode States	148
spn1201 -	Anti-theft Command States	149
spn1202 -	Anti-theft Password Representation	149
spn1203 -	Engine Auxiliary Coolant Pressure	149
spn1204 -	Electrical Load	150
spn1205 -	Safety Wire Status	150
spn1206 -	Turning Gear Engaged	150
spn1207 -	Engine ECU Temperature (OBSOLETE use SPN 1136)	150
spn1208 -	Pre-filter Oil Pressure	150
spn1209 -	Exhaust Gas Pressure	150
spn1210 -	Fuel Rack Position	151
spn1211 -	Engine Build Hours Reset	151
spn1212 -	Engine Auxiliary Coolant Temperature	151
spn1237 -	Engine Shutdown Override Switch	151
spn1238 -	Traction Control Override Switch	151
spn1239 -	Fuel Leakage 1	152
spn1240 -	Fuel Leakage 2	152
spn1241 -	Mass Flow (Gaseous)	152
spn1242 -	Instantaneous Estimated Brake Power	152
spn1243 -	ABS Fully Operational	152
spn1246 -	Number of Torque History Records	153
spn1247 -	Engine Power	153
spn1248 -	Peak Engine Torque 1	153
spn1249 -	Peak Engine Torque 2	153
spn1250 -	Calibration Record Start Month	153
spn1251 -	Calibration Record Start Day	154
spn1252 -	Calibration Record Start Year	154
spn1253 -	Calibration Record Duration Time	154
spn1254 -	Torque Limiting Feature Status	154
spn1255 -	Transmission Gear Ratio 1	155
spn1256 -	Engine Torque Limit 1, Transmission	155
spn1257 -	Transmission Gear Ratio 2	155
spn1258 -	Engine Torque Limit 2, Transmission	155
spn1259 -	Transmission Gear Ratio 3	155
spn1260 -	Engine Torque Limit 3, Transmission	156
spn1261 -	Engine Torque Limit 4, Transmission	156
spn1262 -	Engine Torque Limit 5, Switch	156
spn1263 -	Engine Torque Limit 6, Axle Input	156
spn1264 -	Extended Crankcase Blow-by Pressure - duplicate (see SPN 22)	157
spn1320 -	Externally Supplied Air Pressure	157
spn1349 -	Injector Metering Rail 2 Pressure	157
spn1350 -	Time Since Last Service	157
spn1376 -	Battery 2 Potential (Voltage) (duplicate - see also SPN 444)	157
spn1379 -	Service Component Identification	158
spn1380 -	Engine Oil Level Remote Reservoir	158
spn1381 -	Fuel Supply Pump Inlet Pressure	158
spn1382 -	Fuel Filter (suction side) Differential Pressure	158
spn1385 -	Auxiliary Temperature #1 (duplicate see also SPN 441)	158
spn1386 -	Auxiliary Temperature #2 (duplicate see also SPN 442)	159
spn1387 -	Auxiliary Pressure #1	159
spn1388 -	Auxiliary Pressure #2	159
spn1389 -	Fuel Specific Gravity	159

spn1390 -	Absolute Fuel Valve Inlet Pressure	159
spn1391 -	Outlet to Inlet Fuel Valve Differential Pressure	160
spn1392 -	Air to Fuel Differential Pressure	160
spn1393 -	Cylinder 1 Ignition Transformer Secondary Output	160
spn1394 -	Cylinder 2 Ignition Transformer Secondary Output	160
spn1395 -	Cylinder 3 Ignition Transformer Secondary Output	160
spn1396 -	Cylinder 4 Ignition Transformer Secondary Output	161
spn1397 -	Cylinder 5 Ignition Transformer Secondary Output	161
spn1398 -	Cylinder 6 Ignition Transformer Secondary Output	161
spn1399 -	Cylinder 7 Ignition Transformer Secondary Output	161
spn1400 -	Cylinder 8 Ignition Transformer Secondary Output	161
spn1401 -	Cylinder 9 Ignition Transformer Secondary Output	162
spn1402 -	Cylinder 10 Ignition Transformer Secondary Output	162
spn1403 -	Cylinder 11 Ignition Transformer Secondary Output	162
spn1404 -	Cylinder 12 Ignition Transformer Secondary Output	162
spn1405 -	Cylinder 13 Ignition Transformer Secondary Output	163
spn1406 -	Cylinder 14 Ignition Transformer Secondary Output	163
spn1407 -	Cylinder 15 Ignition Transformer Secondary Output	163
spn1408 -	Cylinder 16 Ignition Transformer Secondary Output	163
spn1409 -	Cylinder 17 Ignition Transformer Secondary Output	163
spn1410 -	Cylinder 18 Ignition Transformer Secondary Output	164
spn1411 -	Cylinder 19 Ignition Transformer Secondary Output	164
spn1412 -	Cylinder 20 Ignition Transformer Secondary Output	164
spn1413 -	Cylinder 1 Ignition Timing	164
spn1414 -	Cylinder 2 Ignition Timing	164
spn1415 -	Cylinder 3 Ignition Timing	164
spn1416 -	Cylinder 4 Ignition Timing	165
spn1417 -	Cylinder 5 Ignition Timing	165
spn1418 -	Cylinder 6 Ignition Timing	165
spn1419 -	Cylinder 7 Ignition Timing	165
spn1420 -	Cylinder 8 Ignition Timing	165
spn1421 -	Cylinder 9 Ignition Timing	166
spn1422 -	Cylinder 10 Ignition Timing	166
spn1423 -	Cylinder 11 Ignition Timing	166
spn1424 -	Cylinder 12 Ignition Timing	166
spn1425 -	Cylinder 13 Ignition Timing	166
spn1426 -	Cylinder 14 Ignition Timing	166
spn1427 -	Cylinder 15 Ignition Timing	167
spn1428 -	Cylinder 16 Ignition Timing	167
spn1429 -	Cylinder 17 Ignition Timing	167
spn1430 -	Cylinder 18 Ignition Timing	167
spn1431 -	Cylinder 19 Ignition Timing	167
spn1432 -	Cylinder 20 Ignition Timing	168
spn1433 -	Desired Ignition Timing #1	168
spn1434 -	Desired Ignition Timing #2	168
spn1435 -	Desired Ignition Timing #3	168
spn1436 -	Actual Ignition Timing	168
spn1437 -	Road Speed Limit Status	169
spn1438 -	ABS/EBS Amber Warning Signal (Powered Vehicle)	169
spn1439 -	EBS Red Warning Signal	169
spn1440 -	Fuel Flow Rate 1	169
spn1441 -	Fuel Flow Rate 2	169
spn1442 -	Fuel Valve 1 Position	170
spn1443 -	Fuel Valve 2 Position	170
spn1444 -	Cylinder 1 Combustion Time	170
spn1445 -	Cylinder 2 Combustion Time	170
spn1446 -	Cylinder 3 Combustion Time	170
spn1447 -	Cylinder 4 Combustion Time	171
spn1448 -	Cylinder 5 Combustion Time	171
spn1449 -	Cylinder 6 Combustion Time	171
spn1450 -	Cylinder 7 Combustion Time	171
spn1451 -	Cylinder 8 Combustion Time	171
spn1452 -	Cylinder 9 Combustion Time	172
spn1453 -	Cylinder 10 Combustion Time	172

spn1454 -	Cylinder 11 Combustion Time	172
spn1455 -	Cylinder 12 Combustion Time	172
spn1456 -	Cylinder 13 Combustion Time	172
spn1457 -	Cylinder 14 Combustion Time	173
spn1458 -	Cylinder 15 Combustion Time	173
spn1459 -	Cylinder 16 Combustion Time	173
spn1460 -	Cylinder 17 Combustion Time	173
spn1461 -	Cylinder 18 Combustion Time	173
spn1462 -	Cylinder 19 Combustion Time	174
spn1463 -	Cylinder 20 Combustion Time	174
spn1464 -	Desired Combustion Time	174
spn1465 -	Average Engine Combustion Time	174
spn1466 -	Steer Channel Mode	174
spn1467 -	Trailer/tag Channel Mode	175
spn1468 -	Drive Channel Mode	175
spn1469 -	PCU Drive Solenoid Status	175
spn1470 -	PCU Steer Solenoid Status	175
spn1471 -	Tire Pressure Supply Switch Status	176
spn1472 -	PCU Deflate Solenoid Status	176
spn1473 -	PCU Control Solenoid Status	176
spn1474 -	PCU Supply Solenoid Status	176
spn1475 -	PCU Trailer, Tag or Push Solenoid Status	176
spn1476 -	Engine Oil Specific Resistance	177
spn1477 -	Engine Oil Kinematic Viscosity	177
spn1478 -	Engine Oil Relative Dielectricity	177
spn1480 -	Source Address of Controlling Device for Retarder Control	177
spn1481 -	Source Address of Controlling Device for Brake Control	177
spn1482 -	Source Address of Controlling Device for Transmission Control	178
spn1483 -	Source Address of Controlling Device for Engine Control	178
spn1487 -	Illumination Brightness Percent	178
spn1504 -	Operator Seat Switch	179
spn1573 -	LED Display Data #1	179
spn1574 -	Laser Strike Vertical Deviation	179
spn1575 -	Modify Set Point	179
spn1576 -	Mast Position	180
spn1577 -	Blade Duration and Direction	180
spn1578 -	Blade Control Mode	180
spn1579 -	Laser Tracer Target Deviation	180
spn1580 -	Laser Tracer Vertical Distance	180
spn1581 -	Laser Tracer Horizontal Deviation	181
spn1582 -	LED Display Data #2	181
spn1583 -	Laser Tracer Information	181
spn1584 -	Service Component Identification	181
spn1585 -	Powered Vehicle Weight	182
spn1586 -	Speed of forward vehicle	182
spn1587 -	Distance to forward vehicle	182
spn1588 -	Adaptive Cruise Control Set Speed	182
spn1589 -	Adaptive cruise control set distance mode	182
spn1590 -	Adaptive Cruise Control Mode	183
spn1591 -	Road curvature	183
spn1592 -	Front Axle, Left Wheel Speed	183
spn1593 -	Front axle, right wheel speed	184
spn1594 -	Rear axle, left wheel speed	184
spn1595 -	Rear axle, right wheel speed	184
spn1601 -	Local minute offset	184
spn1602 -	Local hour offset	184
spn1603 -	Adjust seconds	185
spn1604 -	Adjust minutes	185
spn1605 -	Adjust hours	185
spn1606 -	Adjust month	185
spn1607 -	Adjust day	185
spn1608 -	Adjust year	186
spn1609 -	Adjust local minute offset	186
spn1610 -	Adjust local hour offset	186

spn1611 -	Drive recognize	186
spn1612 -	Driver 1 working state	186
spn1613 -	Driver 2 working state	187
spn1614 -	Overspeed	187
spn1615 -	Driver card, driver 1	187
spn1616 -	Driver card, driver 2	187
spn1617 -	Driver 1 Time Related States	187
spn1618 -	Driver 2 Time Related States	188
spn1619 -	Direction indicator	188
spn1620 -	Tachograph performance	188
spn1621 -	Handling information	188
spn1622 -	System event	189
spn1623 -	Tachograph output shaft speed	189
spn1624 -	Tachograph vehicle speed	189
spn1625 -	Driver 1 identification	189
spn1626 -	Driver 2 identification	189
spn1632 -	Torque Limit Feature	189
spn1633 -	Cruise Control Pause Switch	190
spn1636 -	Intake Manifold 1 Air Temperature (High Resolution)	190
spn1637 -	Engine Coolant Temperature (High Resolution)	190
spn1638 -	Hydraulic Temperature	190
spn1639 -	Fan Speed	190
spn1653 -	Vehicle Limiting Speed Governor Enable Switch	191
spn1654 -	Vehicle Limiting Speed Governor Increment Switch	191
spn1655 -	Vehicle Limiting Speed Governor Decrement Switch	191
spn1656 -	Engine Automatic Start Enable Switch	191
spn1665 -	Turbo Oil Level Switch	191
spn1666 -	Automatic Gear Shifting Enable Switch	192
spn1667 -	Retarder Requesting Brake Light	192
spn1675 -	Engine Starter Mode	192
spn1676 -	Auxiliary Heater Water Pump Status	192
spn1677 -	Auxiliary Heater Mode	192
spn1678 -	Cab Ventilation	193
spn1679 -	Engine Heating Zone	193
spn1680 -	Cab Heating Zone	193
spn1681 -	Battery Main Switch Hold State	193
spn1682 -	Battery Main Switch Hold Request	193
spn1683 -	Auxiliary Heater Mode Request	194
spn1684 -	Auxiliary Heater Coolant Pump Request	194
spn1685 -	Request Engine Zone Heating	194
spn1686 -	Request Cab Zone Heating	194
spn1687 -	Auxiliary Heater Output Coolant Temperature	194
spn1688 -	Auxiliary Heater Input Air Temperature	195
spn1689 -	Auxiliary Heater Output Power Percent	195
spn1690 -	Auxiliary Heater Maximum Output Power	195
spn1691 -	Cab Interior Temperature Command	195
spn1692 -	Desired Absolute Intake Manifold Pressure (Turbo Boost Limit)	195
spn1693 -	Wastegate Valve Position	196
spn1694 -	Gas Mass Flow Sensor Fueling Correction	196
spn1695 -	Exhaust Gas Oxygen Sensor Fueling Correction	196
spn1696 -	Exhaust Gas Oxygen Sensor Closed Loop Operation	196
spn1697 -	CTI Wheel End Electrical Fault	196
spn1698 -	CTI Tire Status	197
spn1699 -	CTI Wheel Sensor Status	197
spn1700 -	Lane Departure Imminent, Left Side	197
spn1701 -	Lane Departure Imminent, Right Side	197
spn1702 -	Lane Departure Indication Enable Status	197
spn1710 -	Lane Tracking Status Left Side	198
spn1711 -	Lane Tracking Status Right Side	198
spn1712 -	Extended Range Requested Speed Control Range Upper Limit (Engine configuration)	198
spn1713 -	Hydraulic Oil Filter Restriction Switch	198
spn1714 -	Operator Seat Direction Switch	198
spn1715 -	Drivers Demand Retarder - Percent Torque	199
spn1716 -	Retarder Selection, non-engine	199

spn1717 -	Actual Maximum Available Retarder - Percent Torque	199
spn1718 -	Damper Stiffness Request Front Axle	199
spn1719 -	Damper Stiffness Request Rear Axle	200
spn1720 -	Damper Stiffness Request Lift / Tag Axle	200
spn1721 -	Relative Level Front Axle Left	200
spn1722 -	Relative Level Front Axle Right	200
spn1723 -	Relative Level Rear Axle Right	200
spn1724 -	Relative Level Rear Axle Left	201
spn1725 -	Bellow Pressure Front Axle Left	201
spn1726 -	Bellow Pressure Front Axle Right	201
spn1727 -	Bellow Pressure Rear Axle Left	201
spn1728 -	Bellow Pressure Rear Axle Right	201
spn1729 -	Damper Stiffness Front Axle	202
spn1730 -	Damper Stiffness Rear Axle	202
spn1731 -	Damper Stiffness Lift / Tag Axle	202
spn1732 -	Level Preset Front Axle Left	202
spn1733 -	Nominal Level Rear Axle	202
spn1734 -	Nominal Level Front Axle	203
spn1735 -	Level Preset Rear Axle Right	205
spn1736 -	Above Nominal Level Rear Axle	205
spn1737 -	Above Nominal Level Front Axle	206
spn1738 -	Below Nominal Level Front Axle	206
spn1739 -	Lifting Control Mode Front Axle	206
spn1740 -	Lowering Control Mode Front Axle	206
spn1741 -	Level Control Mode	206
spn1742 -	Kneeling Information	207
spn1743 -	Lift Axle 1 Position	207
spn1744 -	Door Release	207
spn1745 -	Vehicle Motion Inhibit	207
spn1746 -	Security Device	208
spn1747 -	Kneeling Control Mode Request	208
spn1748 -	Kneeling Request Right Side	208
spn1749 -	Kneeling Request Left Side	208
spn1750 -	Nominal Level Request Rear Axle	208
spn1751 -	Nominal Level Request Front Axle	209
spn1752 -	Lift Axle 1 Position Command	209
spn1753 -	Level Control Mode Request	209
spn1754 -	Below Nominal Level Rear Axle	210
spn1755 -	Lowering Control Mode Rear Axle	210
spn1756 -	Lifting Control Mode Rear Axle	210
spn1757 -	Level Preset Front Axle Right	210
spn1758 -	Level Preset Rear Axle Left	210
spn1759 -	Blade Height Set Point - High Resolution	211
spn1760 -	Gross Combination Vehicle Weight	211
spn1761 -	Catalyst Tank Level	211
spn1762 -	Hydraulic Pressure	211
spn1763 -	Hydraulic Pressure Mode Indicator	211
spn1764 -	Hydraulic Pressure Governor Switch	212
spn1765 -	Requested Fuel Valve 1 Position	212
spn1766 -	Requested Fuel Valve 2 Position	212
spn1767 -	Specific Heat Ratio	212
spn1768 -	Low Limit Threshold for Maximum RPM from Engine	212
spn1769 -	High Limit Threshold for Minimum Continuous Engine RPM	213
spn1770 -	Low Limit Threshold for Maximum Torque from Engine	213
spn1771 -	High Limit Threshold for Minimum Continuous Torque from Engine	213
spn1772 -	Maximum Continuous Engine RPM	213
spn1773 -	Minimum Continuous Engine RPM	213
spn1774 -	Maximum Continuous Engine Torque	214
spn1775 -	Minimum Continuous Engine Torque	214
spn1776 -	Low Limit Threshold for Maximum RPM from Retarder	214
spn1777 -	High Limit Threshold for Minimum Continuous RPM from Retarder	214
spn1778 -	Low Limit Threshold for Maximum Torque from Retarder	214
spn1779 -	High Limit Threshold for Minimum Continuous Torque from Retarder	215
spn1780 -	Maximum Continuous Retarder Speed	215

spn1781 -	Minimum Continuous Retarder Speed	215
spn1782 -	Maximum Continuous Retarder Torque	215
spn1783 -	Minimum Continuous Retarder Torque	215
spn1784 -	Minimum Continuous Engine Speed Limit Request	216
spn1785 -	Maximum Continuous Engine Speed Limit Request	216
spn1786 -	Minimum Continuous Engine Torque Limit Request	216
spn1787 -	Maximum Continuous Engine Torque Limit Request	216
spn1788 -	Minimum Continuous Retarder Speed Limit Request	216
spn1789 -	Maximum Continuous Retarder Speed Limit Request	217
spn1790 -	Minimum Continuous Retarder Torque Limit Request	217
spn1791 -	Maximum Continuous Retarder Torque Limit Request	217
spn1792 -	Tractor-Mounted Trailer ABS Warning Signal	217
spn1793 -	ATC/ASR Information Signal	217
spn1794 -	Engine Moment of Inertia	218
spn1795 -	Alternator Current (High Range/Resolution)	218
spn1796 -	ACC Distance Alert Signal	218
spn1797 -	ACC System Shutoff Warning	218
spn1798 -	ACC Target Detected	218
spn1799 -	Requested ACC Distance Mode	219
spn1800 -	Battery 1 Temperature	219
spn1801 -	Battery 2 Temperature	219
spn1802 -	Intake Manifold 5 Temperature	219
spn1803 -	Intake Manifold 6 Temperature	220
spn1805 -	LED Display Mode Control	220
spn1806 -	LED Display Deadband Control	220
spn1807 -	Steering Wheel Angle	220
spn1808 -	Yaw Rate	220
spn1809 -	Lateral Acceleration	221
spn1810 -	Longitudinal Acceleration	221
spn1811 -	Steering Wheel Turn Counter	221
spn1812 -	Steering Wheel Angle Sensor Type	221
spn1813 -	VDC Information Signal	222
spn1814 -	VDC Fully Operational	222
spn1815 -	VDC brake light request	222
spn1816 -	ROP Engine Control active	222
spn1817 -	YC Engine Control active	222
spn1818 -	ROP Brake Control active	223
spn1819 -	YC Brake Control active	223
spn1820 -	Ramp / Wheel Chair Lift Position	223
spn1821 -	Position of doors	223
spn1822 -	Lift Axle 2 Position	224
spn1823 -	Rear Axle in Bumper Range	224
spn1824 -	Front Axle in Bumper Range	224
spn1825 -	Suspension Remote control 2	224
spn1826 -	Suspension Remote Control 1	224
spn1827 -	Suspension Control Refusal Information	225
spn1828 -	Lift Axle 2 Position Command	225
spn1829 -	Kneeling Command - Rear Axle	225
spn1830 -	Kneeling Command - Front Axle	225
spn1831 -	Electronic Shock Absorber Control Mode - Lift/Tag Axle	226
spn1832 -	Electronic Shock Absorber Control Mode - Rear Axle	226
spn1833 -	Electronic Shock Absorber Control Mode - Front Axle	226
spn1834 -	Total Average Fuel Rate	226
spn1835 -	Total Average Fuel Economy	226
spn1836 -	Trailer ABS Status	227
spn1837 -	Convoy Driving Lamp Select	227
spn1838 -	Convoy Lamp Select	227
spn1839 -	Front Black Out Marker Lamp Select	227
spn1840 -	Rear Black Out Marker Select	227
spn1841 -	Black Out Brake/Stop Lamp Select	228
spn1842 -	Black Out Work Lamp Select	228
spn1843 -	Night Vision Illuminator Select	228
spn1844 -	Operators Black Out Intensity Selection	228
spn1845 -	Transmission Torque Limit	228

spn1846 -	Default Engine Torque Limit	229
spn1849 -	Transmission Requested Range Display Flash State	229
spn1850 -	Transmission Requested Range Display Blank State	230
spn1851 -	Shift Inhibit Indicator	230
spn1852 -	Transmission Mode 1	230
spn1853 -	Transmission Mode 2	230
spn1854 -	Transmission Mode 3	231
spn1855 -	Transmission Mode 4	231
spn1856 -	Seat Belt Switch	231
spn1857 -	Winch Oil Pressure Switch	231
spn2347 -	High Beam Head Light Command	231
spn2348 -	High Beam Head Light Data	232
spn2349 -	Low Beam Head Light Command	232
spn2350 -	Low Beam Head Light Data	232
spn2351 -	Alternate Beam Head Light Command	232
spn2352 -	Alternate Beam Head Light Data	233
spn2353 -	Tractor Front Low Mounted Work Lights Command	233
spn2354 -	Tractor Front Low Mounted Work Lights	233
spn2355 -	Tractor Front High Mounted Work Lights Command	233
spn2356 -	Tractor Front High Mounted Work Lights	233
spn2357 -	Tractor Underside Mounted Work Lights Command	234
spn2358 -	Tractor Underside Mounted Work Lights	234
spn2359 -	Tractor Rear Low Mounted Work Lights Command	234
spn2360 -	Tractor Rear Low Mounted Work Lights	234
spn2361 -	Tractor Rear High Mounted Work Lights Command	234
spn2362 -	Tractor Rear High Mounted Work Lights	235
spn2363 -	Tractor Side Low Mounted Work Lights Command	235
spn2364 -	Tractor Side Low Mounted Work Lights	235
spn2365 -	Tractor Side High Mounted Work Lights Command	235
spn2366 -	Tractor Side High Mounted Work Lights	236
spn2367 -	Left Turn Signal Lights Command	236
spn2368 -	Left Turn Signal Lights	236
spn2369 -	Right Turn Signal Lights Command	236
spn2370 -	Right Turn Signal Lights	236
spn2371 -	Left Stop Light Command	237
spn2372 -	Left Stop Light	237
spn2373 -	Right Stop Light Command	237
spn2374 -	Right Stop Light	237
spn2375 -	Center Stop Light Command	237
spn2376 -	Center Stop Light	238
spn2377 -	Tractor Marker Light Command	238
spn2378 -	Tractor Marker Light	238
spn2379 -	Implement Marker Light Command	238
spn2380 -	Implement Marker Light	238
spn2381 -	Tractor Clearance Light Command	239
spn2382 -	Tractor Clearance Light	239
spn2383 -	Implement Clearance Light Command	239
spn2384 -	Implement Clearance Light	239
spn2385 -	Rotating Beacon Light Command	240
spn2386 -	Rotating Beacon Light	240
spn2387 -	Tractor Front Fog Lights Command	240
spn2388 -	Tractor Front Fog Lights	240
spn2389 -	Rear Fog Light Command	240
spn2390 -	Rear Fog Lights	241
spn2391 -	Back Up Light and Alarm Horn Command	241
spn2392 -	Back Up Light and Alarm Horn	241
spn2393 -	Lighting Data Request Command	241
spn2394 -	Implement Rear Work Light	241
spn2395 -	Implement OEM Option 1 Light Command	242
spn2396 -	Implement OEM Option 1 Light	242
spn2397 -	Implement OEM Option 2 Light Command	242
spn2398 -	Implement OEM Option 2 Light	242
spn2399 -	Implement Left Forward Work Light Command	242
spn2400 -	Implement Left Forward Work Light	243

spn2401 -	Implement Right Forward Work Light Command	243
spn2402 -	Implement Right Forward Work Light	243
spn2403 -	Running Light Command	243
spn2404 -	Running Light	244
spn2405 -	Implement Rear Work Light Command	244
spn2406 -	Implement Right Facing Work Light Command	244
spn2407 -	Implement Right Facing Work Light	244
spn2430 -	Main Radiator/Engine Coolant Level	244
spn2432 -	Engine Demand - Percent Torque	244
spn2433 -	Right Manifold Exhaust Gas Temperature	251
spn2434 -	Left Manifold Exhaust Gas Temperature	251
spn2435 -	Sea Water Pump Outlet Pressure	252
spn2536 -	Transmission Mode 1 Indicator	252
spn2537 -	Transmission Mode 2 Indicator	252
spn2538 -	Transmission Mode 3 Indicator	252
spn2539 -	Transmission Mode 4 Indicator	253
spn2576 -	Laser Receiver Type	253
spn2577 -	Display Deadbands	253
spn2578 -	LED Pattern Control	253
spn2579 -	Net Battery Current (High Range/Resolution)	253
spn2580 -	Hydraulic Brake Pressure Circuit 1	254
spn2581 -	Hydraulic Brake Pressure Circuit 2	254
spn2582 -	Hydraulic Brake Pressure Supply State Circuit 1	254
spn2583 -	Hydraulic Brake Pressure Supply State Circuit 2	254
spn2584 -	Hydraulic Brake Pressure Warning State Circuit 1	254
spn2585 -	Hydraulic Brake Pressure Warning State Circuit 2	255
spn2586 -	Tire Air Leakage Rate	255
spn2587 -	Tire Pressure Threshold Detection	255
spn2588 -	Maximum Vehicle Speed Limit 1	255
spn2589 -	Maximum Vehicle Speed Limit 2	256
spn2590 -	Maximum Vehicle Speed Limit 3	256
spn2591 -	Maximum Vehicle Speed Limit 4	256
spn2592 -	Maximum Vehicle Speed Limit 5	256
spn2593 -	Maximum Vehicle Speed Limit 6	256
spn2594 -	Maximum Vehicle Speed Limit 7	257
spn2595 -	Applied Vehicle Speed Limit	257
spn2596 -	Selected Maximum Vehicle Speed Limit	257
spn2597 -	Implement Left Facing Work Light Command	257
spn2598 -	Implement Left Facing Work Light	257
spn2599 -	Fire Apparatus Pump Engagement	258
spn2600 -	Payload Percentage	258
spn2601 -	Travel Velocity Control Position	258
spn2602 -	Hydraulic Oil Level	258
spn2603 -	Pneumatic Supply Pressure Request	258
spn2604 -	Parking and/or Trailer Air Pressure Request	259
spn2605 -	Service Brake Air Pressure Request, Circuit #1	259
spn2606 -	Service Brake Air Pressure Request, Circuit #2	259
spn2607 -	Auxiliary Equipment Supply Pressure Request	259
spn2608 -	Air Suspension Supply Pressure Request	260
spn2609 -	Cab A/C Refrigerant Compressor Outlet Pressure	260
spn2610 -	Solar Intensity Percent	260
spn2611 -	Solar Sensor Maximum	260
spn2612 -	Front Wheel Drive Actuator Status	260
spn2613 -	Drive Axle Lube Pressure	261
spn2614 -	Steering Axle Lube Pressure	261
spn2615 -	Throttle Synchronization Mode Status	261
spn2616 -	Trolling Mode Status	261
spn2617 -	Slow Vessel Mode Status	261
spn2629 -	Turbocharger 1 Compressor Outlet Temperature	262
spn2659 -	EGR Mass Flow Rate	262
spn2660 -	Joystick 1 X-Axis Position	262
spn2661 -	Joystick 1 Y-Axis Position	262
spn2662 -	Joystick 1 Grip X-Axis Position	263
spn2663 -	Joystick 1 Grip Y-Axis Position	263

spn2664 - Joystick 1 Theta-Axis Position	263
spn2665 - Joystick 1 X-Axis Lever Right Positive Position Status	263
spn2666 - Joystick 1 Y-Axis Lever Forward Positive Position Status	263
spn2667 - Joystick 1 Grip X-Axis Lever Right Positive Position Status	264
spn2668 - Joystick 1 Grip Y-Axis Lever Forward Positive Position Status	264
spn2669 - Joystick 1 Theta-Axis Clockwise Positive Position Status	264
spn2670 - Joystick 1 X-Axis Lever Left Negative Position Status	264
spn2671 - Joystick 1 Y-Axis Lever Back Negative Position Status	265
spn2672 - Joystick 1 Grip X-Axis Lever Left Negative Position Status	265
spn2673 - Joystick 1 Grip Y-Axis Lever Back Negative Position Status	265
spn2674 - Joystick 1 Theta-Axis Counter Clockwise Negative Position Status	265
spn2675 - Joystick 1 X-Axis Neutral Position Status	265
spn2676 - Joystick 1 Y-Axis Neutral Position Status	266
spn2677 - Joystick 1 Grip X-Axis Neutral Position Status	266
spn2678 - Joystick 1 Grip Y-Axis Neutral Position Status	266
spn2679 - Joystick 1 Theta-Axis Neutral Position Status	266
spn2680 - Joystick 1 X-Axis Detent Position Status	267
spn2681 - Joystick 1 Y-Axis Detent Position Status	267
spn2682 - Joystick 1 Grip X-Axis Detent Position Status	267
spn2683 - Joystick 1 Grip Y-Axis Detent Position Status	267
spn2684 - Joystick 1 Theta-Axis Detent Position Status	267
spn2685 - Joystick 1 Button 1 Pressed Status	268
spn2686 - Joystick 1 Button 2 Pressed Status	268
spn2687 - Joystick 1 Button 3 Pressed Status	268
spn2688 - Joystick 1 Button 4 Pressed Status	268
spn2689 - Joystick 1 Button 5 Pressed Status	268
spn2690 - Joystick 1 Button 6 Pressed Status	269
spn2691 - Joystick 1 Button 7 Pressed Status	269
spn2692 - Joystick 1 Button 8 Pressed Status	269
spn2693 - Joystick 1 Button 9 Pressed Status	269
spn2694 - Joystick 1 Button 10 Pressed Status	269
spn2695 - Joystick 1 Button 11 Pressed Status	270
spn2696 - Joystick 1 Button 12 Pressed Status	270
spn2697 - Joystick 2 X-Axis Position	270
spn2698 - Joystick 2 Y-Axis Position	270
spn2699 - Joystick 2 Grip X-Axis Position	270
spn2700 - Joystick 2 Grip Y-Axis Position	271
spn2701 - Joystick 2 Theta-Axis Position	271
spn2702 - Joystick 2 X-Axis Lever Right Positive Position Status	271
spn2703 - Joystick 2 Y-Axis Lever Forward Positive Position Status	271
spn2704 - Joystick 2 Grip X-Axis Lever Right Positive Position Status	272
spn2705 - Joystick 2 Grip Y-Axis Lever Forward Positive Position Status	272
spn2706 - Joystick 2 Theta-Axis Clockwise Positive Position Status	272
spn2707 - Joystick 2 X-Axis Lever Left Negative Position Status	272
spn2708 - Joystick 2 Y-Axis Lever Back Negative Position Status	273
spn2709 - Joystick 2 Grip X-Axis Lever Left Negative Position Status	273
spn2710 - Joystick 2 Grip Y-Axis Lever Back Negative Position Status	273
spn2711 - Joystick 2 Theta-Axis Counter Clockwise Negative Position Status	273
spn2712 - Joystick 2 X-Axis Neutral Position Status	273
spn2713 - Joystick 2 Y-Axis Neutral Position Status	274
spn2714 - Joystick 2 Grip X-Axis Neutral Position Status	274
spn2715 - Joystick 2 Grip Y-Axis Neutral Position Status	274
spn2716 - Joystick 2 Theta-Axis Neutral Position Status	274
spn2717 - Joystick 2 X-Axis Detent Position Status	275
spn2718 - Joystick 2 Y-Axis Detent Position Status	275
spn2719 - Joystick 2 Grip X-Axis Detent Position Status	275
spn2720 - Joystick 2 Grip Y-Axis Detent Position Status	275
spn2721 - Joystick 2 Theta-Axis Detent Position Status	275
spn2722 - Joystick 2 Button 1 Pressed Status	276
spn2723 - Joystick 2 Button 2 Pressed Status	276
spn2724 - Joystick 2 Button 3 Pressed Status	276
spn2725 - Joystick 2 Button 4 Pressed Status	276
spn2726 - Joystick 2 Button 5 Pressed Status	276
spn2727 - Joystick 2 Button 6 Pressed Status	277

spn2728 -	Joystick 2 Button 7 Pressed Status	277
spn2729 -	Joystick 2 Button 8 Pressed Status	277
spn2730 -	Joystick 2 Button 9 Pressed Status	277
spn2731 -	Joystick 2 Button 10 Pressed Status	277
spn2732 -	Joystick 2 Button 11 Pressed Status	278
spn2733 -	Joystick 2 Button 12 Pressed Status	278
spn2734 -	Joystick 3 X-Axis Position	278
spn2735 -	Joystick 3 Y-Axis Position	278
spn2736 -	Joystick 3 Grip X-Axis Position	278
spn2737 -	Joystick 3 Grip Y-Axis Position	279
spn2738 -	Joystick 3 Theta-Axis Position	279
spn2739 -	Joystick 3 X-Axis Lever Right Positive Position Status	279
spn2740 -	Joystick 3 Y-Axis Lever Forward Positive Position Status	279
spn2741 -	Joystick 3 Grip X-Axis Lever Right Positive Position Status	280
spn2742 -	Joystick 3 Grip Y-Axis Lever Forward Positive Position Status	280
spn2743 -	Joystick 3 Theta-Axis Clockwise Positive Position Status	280
spn2744 -	Joystick 3 X-Axis Lever Left Negative Position Status	280
spn2745 -	Joystick 3 Y-Axis Lever Back Negative Position Status	281
spn2746 -	Joystick 3 Grip X-Axis Lever Left Negative Position Status	281
spn2747 -	Joystick 3 Grip Y-Axis Lever Back Negative Position Status	281
spn2748 -	Joystick 3 Theta-Axis Counter Clockwise Negative Position Status	281
spn2749 -	Joystick 3 X-Axis Neutral Position Status	281
spn2750 -	Joystick 3 Y-Axis Neutral Position Status	282
spn2751 -	Joystick 3 Grip X-Axis Neutral Position Status	282
spn2752 -	Joystick 3 Grip Y-Axis Neutral Position Status	282
spn2753 -	Joystick 3 Theta-Axis Neutral Position Status	282
spn2754 -	Joystick 3 X-Axis Detent Position Status	283
spn2755 -	Joystick 3 Y-Axis Detent Position Status	283
spn2756 -	Joystick 3 Grip X-Axis Detent Position Status	283
spn2757 -	Joystick 3 Grip Y-Axis Detent Position Status	283
spn2758 -	Joystick 3 Theta-Axis Detent Position Status	283
spn2759 -	Joystick 3 Button 1 Pressed Status	284
spn2760 -	Joystick 3 Button 2 Pressed Status	284
spn2761 -	Joystick 3 Button 3 Pressed Status	284
spn2762 -	Joystick 3 Button 4 Pressed Status	284
spn2763 -	Joystick 3 Button 5 Pressed Status	284
spn2764 -	Joystick 3 Button 6 Pressed Status	285
spn2765 -	Joystick 3 Button 7 Pressed Status	285
spn2766 -	Joystick 3 Button 8 Pressed Status	285
spn2767 -	Joystick 3 Button 9 Pressed Status	285
spn2768 -	Joystick 3 Button 10 Pressed Status	285
spn2769 -	Joystick 3 Button 11 Pressed Status	286
spn2770 -	Joystick 3 Button 12 Pressed Status	286
spn2789 -	Calculated Turbocharger 1 Turbine Inlet Temperature	286
spn2790 -	Calculated Turbocharger 1 Compressor Outlet Temperature	286
spn2791 -	Exhaust Gas Recirculation (EGR) Valve Control	286
spn2792 -	Variable Geometry Turbocharger (VGT) Air Control Shutoff Valve	287
spn2793 -	Laser Strike Data Latency	287
spn2794 -	Absolute Laser Strike Position	287
spn2795 -	VGT 1 Actuator Position	287
spn2796 -	Transfer Case Selector Switch	288
spn2799 -	Turbocharger 2 Compressor Outlet Temperature	288
spn2800 -	Turbocharger 3 Compressor Outlet Temperature	288
spn2801 -	Turbocharger 4 Compressor Outlet Temperature	288
spn2802 -	Data Memory Usage	288
spn2803 -	Keep-Alive Battery Consumption	289
spn2804 -	FMS-standard Diagnostics Supported	289
spn2805 -	FMS-standard Requests Supported	289
spn2806 -	FMS-standard SW-version supported.	289
5.3.	Parameter Group Definitions	290
pgn0 -	Torque/Speed Control 1 - TSC1	290
pgn256 -	Transmission Control 1 - TC1	290
pgn52992 -	Continuous Torque & Speed Limit Request - CTL	291
pgn53248 -	Cab Illumination Message - CL	294

pgn53504 -	Air Suspension Control 6 - ASC6	295
pgn53760 -	Air Suspension Control 2 - ASC2	295
pgn54528 -	Time/Date Adjust - TDA	295
pgn56320 -	Anti-theft Status - ATS	296
pgn56576 -	Anti-theft Request - ATR	302
pgn56832 -	Reset - RESET	303
pgn57344 -	Cab Message 1 - CM1	303
pgn61440 -	Electronic Retarder Controller 1 - ERC1	304
pgn61441 -	Electronic Brake Controller 1 - EBC1	304
pgn61442 -	Electronic Transmission Controller 1 - ETC1	305
pgn61443 -	Electronic Engine Controller 2 - EEC2	305
pgn61444 -	Electronic Engine Controller 1 - EEC1	306
pgn61445 -	Electronic Transmission Controller 2 - ETC2	306
pgn61446 -	Electronic Axle Controller 1 - EAC1	307
pgn61447 -	Forward Lane Image urgent msg - FLI1	307
pgn61448 -	Hydraulic Pressure Governor Info - HPG	307
pgn61449 -	Vehicle Dynamic Stability Control 2 - VDC2	308
pgn61450 -	Engine Gas Flow Rate - EGF1	308
pgn64977 -	FMS-standard Interface Identity/Capabilities - FMS	308
pgn64978 -	ECU Performance - EP	309
pgn64979 -	Turbocharger Information 6 - TCI6	309
pgn64980 -	Cab Message 3 - CM3	309
pgn64981 -	Electronic Engine Controller 5 - EEC5	309
pgn64982 -	Basic Joystick Message 1 - BJM1	310
pgn64983 -	Extended Joystick Message 1 - EJM1	311
pgn64984 -	Basic Joystick Message 2 - BJM2	312
pgn64985 -	Extended Joystick Message 2 - EJM2	313
pgn64986 -	Basic Joystick Message 3 - BJM3	313
pgn64987 -	Extended Joystick Message 3 - EJM3	314
pgn64988 -	Marine Control Information - MCI	315
pgn64991 -	Front Wheel Drive Status - FWD	315
pgn64992 -	Ambient Conditions 2 - AMB2	316
pgn64993 -	Cab A/C Climate System Information - CACI	316
pgn64994 -	Supply Pressure Demand - SPR	316
pgn64995 -	Equipment Operation and Control - EOAC	317
pgn64996 -	Equipment Performance Data - EPD	317
pgn64997 -	Maximum Vehicle Speed Limit Status - MVS	317
pgn64998 -	Hydraulic Braking System - HBS	318
pgn65031 -	Exhaust Temperature - ET	318
pgn65088 -	Lighting Data - LD	318
pgn65089 -	Lighting Command - LC	319
pgn65099 -	Transmission Configuration 2 - TCFG2	320
pgn65100 -	Military Lighting Command - ML	321
pgn65101 -	Total Averaged Information - TAVG	321
pgn65102 -	Door Control - DC	321
pgn65103 -	Vehicle Dynamic Stability Control 1 - VDC1	322
pgn65104 -	Battery Temperature - BT1	322
pgn65105 -	Adaptive Cruise Control, Operator Input - ACC2	322
pgn65106 -	Vehicle Electrical Power 3 - VP3	323
pgn65107 -	Retarder Continuous Torque & Speed Limit - RTC1	323
pgn65108 -	Engine Continuous Torque & Speed Limit - ECT1	323
pgn65109 -	Gaseous Fuel Properties - GFD	324
pgn65110 -	TANK Information 1 - TII	324
pgn65111 -	Air Suspension Control 5 - ASC5	324
pgn65112 -	Air Suspension Control 4 - ASC4	325
pgn65113 -	Air Suspension Control 3 - ASC3	325
pgn65114 -	Air Suspension Control 1 - ASC1	325
pgn65115 -	Forward Lane Image - FLI2	326
pgn65126 -	Battery Main Switch Information - BM	326
pgn65127 -	Climate Control Configuration - CCC	327
pgn65128 -	Vehicle Fluids - VF	327
pgn65129 -	Engine Temperature 3 - ET3	327
pgn65130 -	Engine Fuel/lube systems - EFS	327
pgn65131 -	Driver's Identification - DI	328

pgn65132 -	Tachograph - TCO1	328
pgn65133 -	Heater Information - HTR	329
pgn65134 -	High Resolution Wheel Speed - HRW	329
pgn65135 -	Adaptive Cruise Control - ACC1	329
pgn65136 -	Combination Vehicle Weight - CVW	331
pgn65137 -	Laser Tracer Position - LTP	331
pgn65138 -	Laser Leveling System Blade Control - LBC	332
pgn65139 -	Laser Receiver Mast Position - LMP	332
pgn65140 -	Modify Leveling System Control Set Point - LSP	332
pgn65141 -	Laser Leveling System Vertical Deviation - LVD	333
pgn65142 -	Laser Leveling System Vertical Position Display Data - LVDD	333
pgn65143 -	Auxiliary Pressures - AP	333
pgn65144 -	Tire Pressure Control Unit Mode and Status - TP1	334
pgn65145 -	Tire Pressure Control Unit Target Pressures - TP2	334
pgn65146 -	Tire Pressure Control Unit Current Pressures - TP3	334
pgn65147 -	Combustion Time 1 - CT1	335
pgn65148 -	Combustion Time 2 - CT2	335
pgn65149 -	Combustion Time 3 - CT3	335
pgn65150 -	Combustion Time 4 - CT4	336
pgn65151 -	Combustion Time 5 - CT5	336
pgn65152 -	Combustion Time 6 - CT6	336
pgn65153 -	Fuel Information 2 (Gaseous) - GF12	336
pgn65154 -	Ignition Timing 1 - IT1	337
pgn65155 -	Ignition Timing 2 - IT2	337
pgn65156 -	Ignition Timing 3 - IT3	337
pgn65157 -	Ignition Timing 4 - IT4	338
pgn65158 -	Ignition Timing 5 - IT5	338
pgn65159 -	Ignition Timing 6 - IT6	338
pgn65160 -	Ignition Transformer Secondary Output 1 - ISO1	339
pgn65161 -	Ignition Transformer Secondary Output 2 - ISO2	339
pgn65162 -	Ignition Transformer Secondary Output 3 - ISO3	339
pgn65163 -	Gaseous Fuel Pressure - GFP	340
pgn65164 -	Auxiliary Analog Information - AAI	340
pgn65165 -	Vehicle Electrical Power 2 - VP2	340
pgn65166 -	Service 2 - S2	341
pgn65167 -	Supply Pressure 2 - SP2	341
pgn65168 -	Engine Torque History - ETH	341
pgn65169 -	Fuel Leakage - FL	342
pgn65170 -	Engine Information - EI	342
pgn65171 -	Engine Electrical System/Module Information - EES	343
pgn65172 -	Engine Auxiliary Coolant - EAC	343
pgn65173 -	Rebuild Information - RBI	343
pgn65174 -	Turbocharger Wastegate - TCW	343
pgn65175 -	Turbocharger Information 5 - TCI5	344
pgn65176 -	Turbocharger Information 4 - TCI4	344
pgn65177 -	Turbocharger Information 3 - TCI3	344
pgn65178 -	Turbocharger Information 2 - TCI2	345
pgn65179 -	Turbocharger Information 1 - TCI1	345
pgn65180 -	Main Bearing Temperature 3 - MBT3	345
pgn65181 -	Main Bearing Temperature 2 - MBT2	346
pgn65182 -	Main Bearing Temperature 1 - MBT1	346
pgn65183 -	Exhaust Port Temperature 5 - EPT5	346
pgn65184 -	Exhaust Port Temperature 4 - EPT4	347
pgn65185 -	Exhaust Port Temperature 3 - EPT3	347
pgn65186 -	Exhaust Port Temperature 2 - EPT2	347
pgn65187 -	Exhaust Port Temperature 1 - EPT1	348
pgn65188 -	Engine Temperature 2 - ET2	348
pgn65189 -	Intake Manifold Information 2 - IMT2	348
pgn65190 -	Intake Manifold Information 1 - IMT1	348
pgn65191 -	Alternator Temperature - AT	349
pgn65192 -	Articulation Control - AC	349
pgn65193 -	Exhaust Oxygen 1 - EO1	349
pgn65194 -	Alternate Fuel 2 - AF2	350
pgn65195 -	Electronic Transmission Controller 6 - ETC6	350

pgn65196 -	Wheel Brake Lining Remaining Information - EBC4	350
pgn65197 -	Wheel Application Pressure High Range Information - EBC3	351
pgn65198 -	Air Supply Pressure - AIR1	351
pgn65199 -	Fuel Consumption (Gaseous) - GFC	351
pgn65200 -	Trip Time Information 2 - TTI2	352
pgn65201 -	ECU History - EH	352
pgn65202 -	Fuel Information 1 (Gaseous) - GFI1	352
pgn65203 -	Fuel Information (Liquid) - LFI	353
pgn65204 -	Trip Time Information 1 - TTI1	353
pgn65205 -	Trip Shutdown Information - TSI	353
pgn65206 -	Trip Vehicle Speed/Cruise Distance Information - TVI	354
pgn65207 -	Engine Speed/Load Factor Information - LF	354
pgn65208 -	Trip Fuel Information (Gaseous) - GTFI	354
pgn65209 -	Trip Fuel Information (Liquid) - LTFI	354
pgn65210 -	Trip Distance Information - TDI	355
pgn65211 -	Trip Fan Information - TFI	355
pgn65212 -	Compression/Service Brake Information - CBI	355
pgn65213 -	Fan Drive - FD	356
pgn65214 -	Electronic Engine Controller 4 - EEC4	356
pgn65215 -	Wheel Speed Information - EBC2	356
pgn65216 -	Service Information - SERV	357
pgn65217 -	High Resolution Vehicle Distance - VDHR	357
pgn65218 -	Electronic Retarder Controller 2 - ERC2	357
pgn65219 -	Electronic Transmission Controller 5 - ETC5	358
pgn65221 -	Electronic Transmission Controller 4 - ETC4	358
pgn65223 -	Electronic Transmission Controller 3 - ETC3	358
pgn65237 -	Alternator Speed - AS	359
pgn65241 -	Auxiliary Input/Output Status - AUXIO	359
pgn65242 -	Software Identification - SOFT	360
pgn65243 -	Engine Fluid Level/Pressure 2 - EFL/P2	360
pgn65244 -	Idle Operation - IO	360
pgn65245 -	Turbocharger - TC	361
pgn65246 -	Air Start Pressure - AIR2	361
pgn65247 -	Electronic Engine Controller 3 - EEC3	361
pgn65248 -	Vehicle Distance - VD	362
pgn65249 -	Retarder Configuration - RC	362
pgn65250 -	Transmission Configuration - TCFG	363
pgn65251 -	Engine Configuration - EC	364
pgn65252 -	Shutdown - SHUTDOWN	367
pgn65253 -	Engine Hours, Revolutions - HOURS	367
pgn65254 -	Time/Date - TD	368
pgn65255 -	Vehicle Hours - VH	368
pgn65256 -	Vehicle Direction/Speed - VDS	368
pgn65257 -	Fuel Consumption (Liquid) - LFC	369
pgn65258 -	Vehicle Weight - VW	369
pgn65259 -	Component Identification - CI	369
pgn65260 -	Vehicle Identification - VI	370
pgn65261 -	Cruise Control/Vehicle Speed Setup - CCSS	370
pgn65262 -	Engine Temperature 1 - ET1	371
pgn65263 -	Engine Fluid Level/Pressure 1 - EFL/P1	371
pgn65264 -	Power Takeoff Information - PTO	371
pgn65265 -	Cruise Control/Vehicle Speed - CCVS	372
pgn65266 -	Fuel Economy (Liquid) - LFE	372
pgn65267 -	Vehicle Position - VP	373
pgn65268 -	Tire Condition - TIRE	373
pgn65269 -	Ambient Conditions - AMB	373
pgn65270 -	Inlet/Exhaust Conditions 1 - IC1	374
pgn65271 -	Vehicle Electrical Power - VEP	374
pgn65272 -	Transmission Fluids - TF	374
pgn65273 -	Axle Information - AI	375
pgn65274 -	Brakes - B	375
pgn65275 -	Retarder fluids - RF	376
pgn65276 -	Dash Display - DD	376
pgn65277 -	Alternate Fuel 1 - A1	376

pgn65278 - Auxiliary Water Pump Pressure - AWPP	376
pgn65279 - Water in Fuel Indicator - WFI	377

1. Scope - As described in the parent document, SAE J1939, there are a minimum of seven documents required to fully define a complete version of this network. This particular SAE Recommended Practice, SAE J1939-71, describes an Application Layer for vehicle use.

2. References -

2.1. Applicable Documents - General information regarding this series of recommended practices is found in SAE J1939. Unless otherwise indicated, the latest issue of SAE publications shall apply.

2.1.1. SAE Publications - Available from SAE, 400 Commonwealth Drive, Warrendale, PA 15096-0001.

2.1.1.1. SAE J1349 - Engine Power Test Code-Spark Ignition and Compression Ignition-Net Power Rating

2.1.1.2. SAE J1843 - Accelerator Pedal Position Sensor for Use with Electronic Controls in Medium- and Heavy-Duty Diesel On-Highway Engines

2.1.1.3. SAE J1922 - Powertrain Control Interface for Electronic Controls Used in Medium and Heavy-Duty Diesel on-Highway Vehicle Applications

2.1.1.4. SAE J1939 - Recommended Practice for a Serial Control and Communication Vehicle Network

2.1.1.5. SAE J1939-21 - Data Link Layer

2.1.2. ISO Publications - Available from ANSI, 11 West 42nd Street, New York, NY 10036-8002.

3. Definitions - See SAE J1939 for terms and definitions that are not defined in this document.

4. Abbreviations -

- ATA - American Trucking Association
- EBS - Electronic Braking System
- Kp - Engine endspeed governor gain
- VMRS - Vehicle Maintenance Reporting System
- CTI - Central Tire Inflation
- VDC - Vehicle Dynamic (Stability) Control
- ROP - Roll Over Prevention
- YC - Yaw Control
- ATA - American Trucking Association
- ACC - Adaptive Cruise Control or Autonomous Cruise Control
- VGT - Variable Geometry Turbocharger
- FMS - Fleet Management System

See SAE J1939 for additional abbreviations that may be used in this document.

5. Technical Requirements - The Application Layer provides a means for application processes to access the OSI

environment. This layer contains management functions and generally useful mechanisms to support applications.

5.1. General Guidelines -

5.1.1. Signal Characterization - It is the intent of the SAE J1939 network to provide current data and signals from a source so that it may be used by other nodes. It is recommended that the time between physical data acquisition of a signal and the transmission of the data should not exceed two times the repetition rate defined for the data. Additional constraints may be defined for certain parameters (see also 5.1.7.2).

5.1.2. Message Format - The message format of SAE J1939 uses the parameter group number as the label for a group of parameters. Each of the parameters within the group can be expressed in ASCII, as scaled data defined by the ranges described in 5.1.4, or as function states consisting of two or more bits. Alphanumeric data will be transmitted with the most significant byte first. Unless otherwise specified, alphanumeric characters will conform to the ISO Latin 1 ASCII character set as shown in 5.1.3. Other parameters consisting of 2 or more data bytes shall be transmitted least significant byte first. The type of data shall also be identified for each parameter. Data may be either status or measured. Status specifies the present state of a multi-state parameter or function as a result of action taken by the transmitting node. This action is the result of a calculation which uses local and/or network "measured" and/or "status" information. Note that specific confirmation of this action is not necessarily assured. For instance, the status may indicate that a solenoid has been activated, yet no measurement may have been taken to ensure the solenoid accomplished its function. Examples of status-type data are: engine brakes are enabled, PTO speed control is active, cruise control is active, the cruise control is in the "set" state of operation (as opposed to a measured indication that the "set" switch contacts are closed), fault codes, torque/speed control override modes, desired speed/speed limit, engine torque mode, engine's desired operating speed, engine's operating speed asymmetry adjustment, etc. Measured data conveys the current value of a parameter as measured or observed by the transmitting node to determine the condition of the defined parameter. Examples of measured-type data are: boost pressure, ignition on/off, cruise set switch activated, maximum cruise speed, cruise set speed, engine speed, percent load at current speed, etc.

5.1.3. ISO Latin 1 Character Set - Horizontal boldface characters are the single hexadecimal digit representing the lower nibble of the single byte code for the character. Vertical boldface characters are the single hexadecimal digit representing the upper nibble of the single byte code for the character. See Figure 1.

	0	1	2	3	4	5	6	7	8	9	A	B	C	D	E	F
0	----- should not be displayed -----															
1	----- should not be displayed -----															
2	space	!	"	#	\$	%	&	'	()	*	+	,	-	.	/
3	0	1	2	3	4	5	6	7	8	9	:	;	<	=	>	?
4	@	A	B	C	D	E	F	G	H	I	J	K	L	M	N	O
5	P	Q	R	S	T	U	V	W	X	Y	Z	[\]	^	_
6	`	a	b	c	d	e	f	g	h	i	j	k	l	m	n	o
7	p	q	r	s	t	u	v	w	x	y	z	{		}	~	nil
8	----- should not be displayed -----															
9	----- should not be displayed -----															
A	nil	ı	ø	£	¤	¥		§	¨	©	ª	«	¬	-	®	¯
B	°	±	²	³	´	µ	¶	·	¸	¹	º	»	¼	½	¾	¿
C	À	Á	Â	Ã	Ä	Å	Æ	Ç	È	É	Ê	Ë	Ì	Í	Î	Ï
D	Ð	Ñ	Ò	Ó	Ô	Õ	Ö	×	Ø	Ù	Ú	Û	Ü	Ý	Þ	ß
E	à	á	â	ã	ä	å	æ	ç	è	é	ê	ë	ì	í	î	ï
F	ð	ñ	ò	ó	ô	õ	ö	÷	ø	ù	ú	û	ü	ý	þ	ÿ

FIGURE 1 -- ISO Latin 1 Character Set

5.1.4. Parameter Ranges - Table 1 defines the ranges used to determine the validity of a transmitted signal. Table 2 defines the ranges used to denote the state of a discrete parameter and Table 3 defines the ranges used to denote the state of a control mode command. The values in the range "error indicator" provide a means for a module to immediately indicate that valid parametric data is not currently available due to some type of error in the sensor, sub-system, or module. The values in the range "not available" provide a means for a module to transmit a message which contains a parameter that is not available or not supported in that module. The values in the range "not requested" provide a means for a device to transmit a command message and identify those parameters where no response is expected from the receiving device.

Table 1: Transmitted Signal Ranges

Range Name	1 Byte	2 Bytes	4 Bytes	ASCII
Valid Signal	0 to 250	0 to 640255	0 to 4211081215	1 to 254
	00 ₁₆ to FA ₁₆	0 to 640255	0 to 4211081215	1 to 254
Parameter Specific Indicator	251	64256 to 64511	4211081216 to 4227858431	None
	FB ₁₆	FB00 ₁₆ to FBFF ₁₆	FBxxxxxx ₁₆	
Reserved range for future indicator bits	252 to 253	64512 to 65023	4227858432 to 4261412863	None
	FC ₁₆ to FD ₁₆	FC00 ₁₆ to FDFF ₁₆	FC000000 ₁₆ to FDFFFFFF ₁₆	
Error indicator	254	65024 to 65279	4261412864 to 4278190079	0
	FE ₁₆	FExx ₁₆	FExxxxxx ₁₆	00 ₁₆
Not available or not requested	255	65280 to 65535	4278190080 to 4294967294	255
	FF ₁₆	FFxx ₁₆	FFxxxxxx ₁₆	FF ₁₆

Table 2: Transmitted Values for Discrete Parameters (Measured)

Range Name	Transmitted Value
Disabled (off, passive, etc.)	00

Range Name	Transmitted Value
Enabled (on, active, etc.)	01
Error indicator	10
Non available or not installed	11

Table 3: Transmitted Values for Control Commands (Status)

Range Name	Transmitted Value
Command to disable function(turnoff, etc.)	00
Command to enable function(turnon, etc.)	01
Reserved	10
Don't care/take no action (leave function as is)	11

If a component failure prevents the transmission of valid data for a parameter, the error indicator as described in Tables 1 and 2 should be used in place of that parameter's data. However, if the measured or calculated data has yielded a value that is valid yet exceeds the defined parameter range, the error indicator should not be used. The data should be transmitted using the appropriate minimum or maximum parameter value.

5.1.5. Assignment of Ranges to new Parameters - This section is intended to define a set of recommended SLOTS (Scaling, Limit, Offset, and Transfer Function) which can be used when parameters are added to SAE J1939. This permits data consistency to be maintained as much as possible between parameters of a given type (temperature, pressure, speed, etc.). Each SLOT is intended to provide a range and resolution suitable for most parameters within a given type. When necessary, a different scaling factor or offset can be used. All SLOTS should be based on a power of 2 scaling from another SLOT. This will minimize the math required for any internal scaling and reduce the opportunity for misinterpreted values. Offsets should be selected preferably on the following basis:

- Offset = 0, or
- Offset = 50% (equal (+/-) range)

Table 4 defines the recommended SLOTS to be used when ranges are assigned to new parameters.

Recommended Slot Definitions			
Parameter	Scaling (Resolution)	Limits(Range)	Parameter Offset Size
ASCII,text	ASCII	0 to 255 per byte	0
ASCII,text	ASCII	0 to 255 per byte	0
ASCII,text	ASCII	0 to 255 per byte	0
ASCII,text	ASCII	0 to 255 per byte	0
ASCII,text	ASCII	0 to 255 per byte	0
ASCII,text	ASCII	0 to 255 per byte	0
ASCII,text	ASCII	0 to 255 per byte	0
Acceleration	1/2048 m/s# per bit	-15.687 to +15.687 m/s#	-15.687 m/s#
Acceleration	0.1 m/s# per bit	-12.5 to +12.5 m/s#	-12.5 m/s#
Angle/Direction	10 ⁻⁷ deg/bit	-210 to 211.1008122 deg	-210 deg
Angle/Direction	1/1024 rad per bit	-31.374 to +31.374 rad	-31.374 rad
Angle/Direction	1/128 deg/bit	-200 to 301.99 deg	-200 deg
Angle/Direction	1/128 deg/bit	0 to 501.99 deg	0
Angle/Direction	1 deg/bit	-125 to 125 deg	-125 deg
Angle/Direction	0.1 sec/bit	-3276.8 to 3148.7 sec	-3,276.8 sec
Bit Field	2 states/1 bit	0 to 1	0
Bit Field	128 states/7 bit	0 to 127	0
Bit Field	256 states/8 bit	0 to 255	0
Bit Field	64 states/6 bit	0 to 63	0
Bit Field	8 states/3 bit	0 to 7	0
Bit Field	16 states/4 bit	0 to 15	0
Bit Field	32 states/5 bit	0 to 31	0
Bit Field	4 states/2 bit	0 to 3	0
Brake Applications	1 brake appl/bit	0 to 4,227,858,431 appl	0
Calendar,days	0.25 days/bit	0 to 62.5 days	0

Parameter	Scaling (Resolution)	Limits(Range)	Parameter Offset Size
Calendar,months	1 month/bit	0 to 250 months	0
Calendar,weeks	1 week/bit	-125 to 125 weeks	-125 weeks
Calendar,years	1 year/bit	1985 to 2235 years	1985 years
Capacity, Battery	1 mAhr/bit	0 to 64255mAhr (64.255Ahr)	0 mAhr
Control byte	1 count/bit	0 to 255	0
Count	1 count/bit	0 to 64,255 counts	0
Count	1 count/bit	0 to 16,777,216 counts	0
Count	1 count/bit	0 to 4,294,967,295 counts	0
Count	1 count/bit	0 to 65,535 counts	0
Count	1 turn/bit	-32 to 29 turns	-32 turns
Count	1 count/bit	0 to 250	0
Count	1 count/bit	0 to 255	0
Dielectricity	0.1/bit	0 to 25.0	0
Distance	0.1 mm/bit	-3,200 to 3,225.5 mm	-3,200 mm
Distance	0.1 mm/bit	0 to 6,425.5 mm	0
Distance	1 m/bit	-125 to 125 m	-125 m
Distance	100 nm/bit	-209.7152 m to 211.3929215 m	-209.7152 m
Distance	0.001 m/bit	0 to 4,211,081.215 m	0
Distance	1 m/bit	0 to 250 m	0
Distance	0.125 m/bit	-2500 to 5531.875 m	-2500 m
Distance	5 m/bit	0 to 21,055,406 km	0
Distance	5 km/bit	-160,635 to 160,640 km	-160,635 km
Distance	0.125 km/bit	0 to 526,385,151.9 km	0
Economy,gaseous	1/512 km/kg per bit	0 to 125.5 km/kg	0
Economy,liquid	1/512 km/L per bit	0 to 125.5 km/L	0
Electrical Current	1 A/bit	-125 to 125 A	-125 A
Electrical Current	1 A/bit	0 to 250 A	0
Electrical Current	1 A/bit	0 to 64,255 Amps	0
Electrical Current	0.05 A/bit	-1600 to 1612.75 A	-1600 A
Electrical Voltage	0.05 V/bit	0 to 3212.75 V	0
Electrical Voltage	1 V/bit	0 to 64,255 Volts	0
Energy	1 kWh/bit	0 to 4211081215 kWh	0
Flow rate,gaseous	0.05 kg/h per bit	0 to 3212.75 kg/h	0
Flow rate,liquid	0.05 L/h per bit	0 to 3,212.75 L/h	0
Flow rate,volumetric	0.1 m ³ /h per bit	0 to 6425.5 m ³ /h	0
Force	5 N/bit	0 to 321,275 N	0
Force	10 N/bit	-320,000 to 322,550 N	-320,000 N
Force	1000 N/bit	-100 kN to 150 kN	-100 kN
Frequency	1/128 Hz/bit	0 to 501.9921875 Hz	0
Fuel Used,gaseous	0.5 kg/bit	0 to 2,105,540,607.5 kg	0
Fuel Used,liquid	0.5 L/bit	0 to 2,105,540,607.5 L	0
Gear Ratio	0.01/bit	0 to 642.55	0
Gear Value	1 gear value/bit	-125 to 125	-125
Gear Value	1 gear value/bit	0 to 250	0
Governor gain	1/1280 %/rpm per bit	0 to 50.2 %/rpm	0
Group Function	1 count/bit	0 to 255	0
Identifier,component/software	ID/bit	0 to 250 ID	0
Inertia	0.004 kg-m ² /bit	0 to 257.02 kg-m ²	0
Intensity, optical	0.4 mW/cm ² per bit	0 to 100 mW/cm ²	0
Kinematic viscosity	1 mm ² /s per bit	0 to 250 mm ² /s	0
Mass,cargo	0.5 kg/bit	0 to 32,127.5 kg	0
Mass,cargo	2 kg/bit	0 to 128,510 kg	0
Mass,cargo	10 kg/bit	0 to 642,550 kg	0
Name (long)	1 count/bit	0 to (2 ⁶⁴ - 1)	0
Name (short)	1 count/bit	0 to (2 ³² - 1)	0
Percent,position/level	0.0025 %/bit	0 to 160.6375 %	0
Percent,position/level	1 %/bit	-125 to 125 %	-125%
Percent,position/level	0.8 %/bit	-100 to 100 %	-100
Percent,position/level	1 %/bit	0 to 250 %	0
Percent,position/level	0.1 %/bit	0 to 102 %	0
Percent,position/level	0.4 %/bit	0 to 100 %	0
Power Factor	1/16384 per bit	-1.00000 to +2.921814	-1
Power, Apparent	1 VA/bit	-2,000,000,000 to +2,211,081,215 VA	0
Power, Reactive	1 VAR/bit	-2,000,000,000 to +2,211,081,215 Var	0
Power, Real	0.5 kW/bit	0 to 32,127.5 kW	0

Parameter	Scaling (Resolution)	Limits(Range)	Parameter Offset Size
Power, Real	1 W/bit	-2,000,000,000 to +2,211,081,215 Watts	0
Power, Real	2 W/bit	0 to 128,510 W	0
Pressure	5 kPa/bit	0 to 1,250 kPa	0
Pressure	100 kPa/bit	0 to 25 MPa	0
Pressure	0.125 kPa/bit	0 to +8031.875 kPa (0 to 1164.62 psi)	0
Pressure	5 kPa/bit	0 to 321,275 kPa	0
Pressure	2 kPa/bit	0 to 128,510 kPa	0
Pressure	0.1 kPa/bit	0 to 6,425.5 kPa	0
Pressure	0.5 kPa/bit	0 to 125 kPa	0
Pressure	2 kPa/bit	0 to 500 kPa	0
Pressure	1/128 kPa/bit	-250 kPa TO 251.99 kPa	-250 kPa
Pressure	1/256 MPa/bit	0 to 251 Mpa	0
Pressure	0.5 kPa/bit	0 to 32,127.5 kPa	0
Pressure	16 kPa/bit	0 to 4000 kPa	0
Pressure	0.05 kPa/bit	0 to 12.5 kPa	0
Pressure	4 kPa/bit	0 to 1000 kPa	0
Pressure	8 kPa/bit	0 to 2,000 kPa	0
Pressure Rate Change	0.1 Pa/s per bit	0 Pa/s to 6425.5 Pa/s	0
Proprietary Data	Manufacturer Determined	Manufacturer Determined	Manufacturer Determined
Ratio	0.1/bit	0 to 25.0	0
Ratio	0.001/bit	0 to 64.255	0
Ratio	1/bit	0 to 250	0
Record	1 record/bit	0 to 250 records	0
Revolutions	1000 r/bit	0 to 4,211,081,215,000 r	0
Road Curvature	1/128 1/km per bit	-250 to 251.992 1/km	-250 1/km
Source Address	1 source address/bit	0 to 255	0
Specific Gravity	0.0001/bit	0 to 6.4255	0
Specific Gravity	0.0001/bit	0 to 6.4255	0
Specific Resistance	0.1 Mohm*m/bit	0 to 25 Mohm*m	0
Step	1 step/bit	0 to 250 steps	0
Temperature	1 deg C/bit	-40 to 210 deg C	-40 deg C
Temperature	0.03125 deg C/bit	-273 to 1735 deg C	-273 deg C
Time	1 hr/bit	0 to 250 hr	0
Time	0.1 s/bit	0 to 25 s	0
Time	0.25 s/bit	0 to 62.5 s	0
Time	51.2 us/bit	0 to 3.289856 s	0
Time	1 ms/bit	0 to 64.255 s	0
Time	1 min/bit	-125 to 125 mins	-125 mins
Time	1 s/bit	0 to 64,255 s	0
Time	1 min/bit	0 to 250 mins	0
Time	0.05 hr/bit	0 to 210,554,060.75 hr	0
Time	1 hr/bit	-125 to 125 hr	-125 hr
Time	1 hr/bit	-32,127 to 32,128 hr	-32,127 hr
Time	0.01 ms/bit	0 to 642.55 ms	0
Time	1 s/bit	0 to 4,211,081,215 s	0
Torque	1 Nm/bit	-32,000 to 32,255 Nm	-32,000 Nm
Torque	30 Nm/bit	0 to 7500 Nm	0
Torque	2 Nm/bit	0 to 128,510 Nm	0
Torque	1 Nm/bit	0 to 64,255 Nm	0
Transfer Data	Request Dependent	9 to 1777 bytes of data	Request Dependent
Transport Data	Request Dependent	9 to 1784 bytes of data	Request Dependent
VariantData	VariantDetermined	VariantDetermined	VariantDetermined
Velocity, linear	1/256 km/h per bit	0 to 250.996 km/h	0
Velocity, linear	0.001 m/s per bit	0 to 64.255 m/s	0 m/s
Velocity, linear	1/128 km/h per bit	-250 to 251.992 km/h	-250 km/h
Velocity, linear	1 km/h per bit	0 to 250 km/h	0
Velocity, linear	1/16 km/h per bit	-7.8125 to 7.8125 km/h	-7.8125 km/h
Velocity, rotational	0.125 rpm/bit	0 to 8,031.875 rpm	0
Velocity, rotational	4 rpm/bit	0 to 257,020 rpm	0
Velocity, rotational	0.5 rpm/bit	0 to 32,127.5 rpm	0
Velocity, rotational	32 rpm/bit	0 to 8,000 rpm	0
Velocity, rotational	10 rpm/bit	0 to 2,500 rpm	0
Velocity,angular	1/8192 rad/s per bit	-3.92 to +3.92 rad/s	-3.92 rad/s
Volume	0.5 L/bit	0 to 2,105,540,607.5 L	0

5.1.6. Adding Parameters to Parameter Groups - Several of the Parameter Groups contain bytes that are not defined and may be replaced with new parameters as appropriate. If existing parameter group definitions do not permit the inclusion of a new parameter, a new parameter group may be defined. Refer to SAE J1939 for additional definitions and abbreviations for instructions for adding new parameters to parameter groups and for requesting new parameter group numbers. In general, parameters should be grouped into parameter groups as follows:

- By function (Oil, Coolant, Fuel, etc.) and not by type (temperature, pressure, speed, etc.)
- With similar update rates (to minimize unnecessary overhead)
- By common subsystem (the device likely to measure and send data)

5.1.7. Transmission Repetition Rates (Update Rates) -

5.1.7.1. Definition of Transmission Repetition Rates - All transmission repetition rates defined in SAE J1939-71 are nominal rates. The actual transmission repetition rate on the network should be at this rate plus/minus the "typical" jitter which occurs in microcontroller based systems. The average rate should be the nominal value.

5.1.7.2. Transmission Repetition Rate for Engine Speed and Directly Associated Data (Crank angle or Time Based Update Rates) - Some parameters may be calculated and/or updated based on engine crank angle rather than at a specific time interval. When this is the case, the reference to a specific update rate is not accurate because this time will change based on the speed of the engine. The primary goal is to minimize the latency associated with sampling, calculating, and transmitting the data without overburdening the network. There are many approaches to sampling the data to be converted and sent over the network. The two preferred approaches are: (a) Time-based sampling, calculating, and transmission; and (b) A hybrid time-based and engine crank angle-based sampling, calculating, and transmission where the number of crank angle degrees between updates is modified based on the current operating speed in order to maintain an update rate within an acceptable range (see Figure 2). Because there are multiple ways to acquire and transmit data onto the network, the following guidelines have been defined for the engine speed and directly associated data.

At speeds above 500 rpm, the time from sampling to message transmission shall not exceed 12 ms. Systems that acquire engine speed information via period measurement inherently have less time delay at higher speeds. Above 1000 rpm, for instance, the time from sampling to message transmission shall range from 5 to 30 ms. Less time is required because the period measurement takes less time at higher speeds. How much time is saved depends on the number of crank angle degrees used to perform the period measurement.

Normal update rates:

- Time based updates will occur every 20 ms.
- Hybrid time based and engine crank angle based updates are shown in Figure 2.

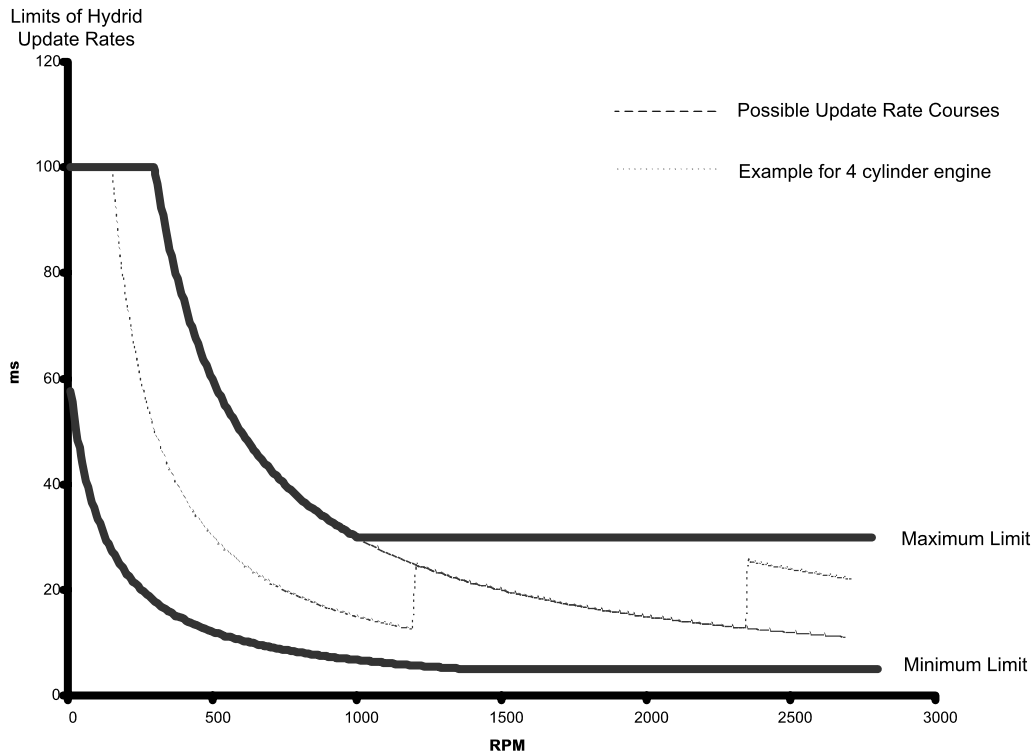

FIGURE 2 -- Limits Of Hybrid Update Rates

5.1.8. Naming Convention For Engine Parameters - When there are multiple instances of the same parameter on the same component (i.e., exhaust ports), the following naming convention will be used. While facing the engine from the flywheel housing, left bank (LB) parameters are assigned prior to the right bank (RB) parameters. Front parameters are assigned prior to the rear or back parameters (with the rear/back being the end containing the flywheel housing). For a six-cylinder in-line engine, the position furthest from the flywheel will be identified as 1. For a 12 cylinder V engine, the position furthest from the flywheel on the left bank will be identified as 1, followed by the position next closest to the flywheel on the left bank. When only one parameter is required or available, the parameter denoted as number 1 should be used. (i.e., an engine having only one turbocharger would use Turbocharger 1 Compressor Inlet Temperature when broadcasting the temperature).

5.1.9. Application Notes -

5.1.9.1. Parameters with Multiple Sources - Each parameter received by a node for control purposes shall be configurable by the system integrator to identify the primary source of the data, as well as the secondary source, if applicable. It is to be expected that the system integrator configure each receiving device on a network identically.

5.2. Parameter Definitions - This section provides a description of each parameter used for in the SAE J1939 network. The description includes data length, data type, resolution, range, and a tag (label) for reference. After power on, a node should internally set the "availability bits" of received parameters as not available and operate with default values until valid data is received. When

transmitting, undefined bytes should be sent as 255 (FF₁₆) and undefined bits should be sent as 1.

spn16 - Fuel Filter (Suction Side) Differential Pressure (see also SPN 1382) - Differential pressure measured across the fuel filter located between the fuel tank and the supply pump. See Figures SPN16_A & SPN16_B.

Data Length: 1 byte
 Resolution: 2 kPa/bit , 0 offset
 Data Range: 0 to 500 kPa
 Type: Measured
 Suspect Parameter Number: 16
 Parameter Group Number: []

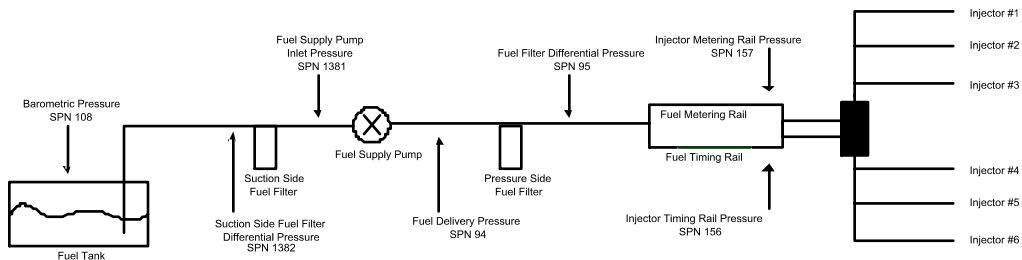

FIGURE SPN16_A -- FUEL SYSTEM WITH RAILS

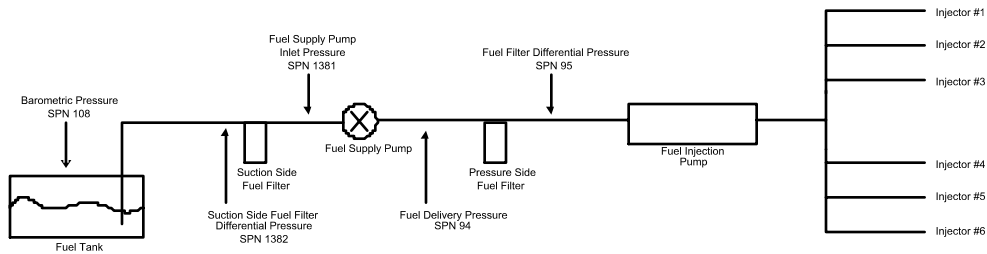

FIGURE SPN16_B -- FUEL SYSTEM WITH PUMP

spn21 - Engine ECU Temperature (use SPN 1136) - Temperature of the engine electronic control unit. (21, 1207 are not to be used - obsolete)

Data Length: 2 bytes
 Resolution: 0.03125 deg C/bit , -273 deg C offset
 Data Range: -273 to 1735 deg C
 Type: Measured
 Suspect Parameter Number: 21
 Parameter Group Number: []

spn22 - Extended Crankcase Blow-by Pressure - Differential crankcase blow-by pressure as measured through a tube with a venturi. (1264 not to be used - obsolete)

Data Length: 1 byte
 Resolution: 0.05 kPa/bit , 0 offset
 Data Range: 0 to 12.5 kPa
 Type: Measured
 Suspect Parameter Number: 22
 Parameter Group Number: [65263]

spn39 - Tire Pressure Check Interval - The interval at which the system will check the tire pressures (e.g., 5, 10, 15 min.).

NOTE - A value of 0 indicates continuous (real time) pressure readings.

Data Length:	1 byte
Resolution:	1 min/bit , 0 offset
Data Range:	0 to 250 mins
Type:	Status
Suspect Parameter Number:	39
Parameter Group Number:	[65144]

spn46 - Pneumatic Supply Pressure - The pneumatic pressure in the main reservoir, sometimes referred to as the wet tank.

Data Length:	1 byte
Resolution:	8 kPa/bit , 0 offset
Data Range:	0 to 2,000 kPa
Type:	Measured
Suspect Parameter Number:	46
Parameter Group Number:	[65198]

spn51 - Throttle Position - The position of the valve used to regulate the supply of a fluid, usually air or fuel/air mixture, to an engine. 0% represents no supply and 100% is full supply.

Data Length:	1 byte
Resolution:	0.4 %/bit , 0 offset
Data Range:	0 to 100 %
Type:	Measured
Suspect Parameter Number:	51
Parameter Group Number:	[65266]

spn52 - Engine Intercooler Temperature - Temperature of liquid found in the intercooler located after the turbocharger.

Data Length:	1 byte
Resolution:	1 deg C/bit , -40 deg C offset
Data Range:	-40 to 210 deg C
Type:	Measured
Suspect Parameter Number:	52
Parameter Group Number:	[65262]

spn53 - Transmission Synchronizer Clutch Value - The current modulated value for the air supply to the synchronizer clutch.

Data Length:	1 byte
Resolution:	0.4 %/bit , 0 offset
Data Range:	0 to 100 %
Type:	Measured
Suspect Parameter Number:	53
Parameter Group Number:	[65221]

spn54 - Transmission Synchronizer Brake Value - The current modulated value for the air supply to the synchronizer

brake.

Data Length: 1 byte
 Resolution: 0.4 %/bit , 0 offset
 Data Range: 0 to 100 %
 Type: Measured
 Suspect Parameter Number: 54
 Parameter Group Number: [65221]

spn59 - Shift Finger Gear Position - The current position of the shift finger in the gear direction.

Data Length: 1 byte
 Resolution: 0.4 %/bit , 0 offset
 Data Range: 0 to 100 %
 Type: Measured
 Suspect Parameter Number: 59
 Parameter Group Number: [65223]

spn60 - Shift Finger Rail Position - The current position of the shift finger in the rail direction.

Data Length: 1 byte
 Resolution: 0.4 %/bit , 0 offset
 Data Range: 0 to 100 %
 Type: Measured
 Suspect Parameter Number: 60
 Parameter Group Number: [65223]

spn69 - Two Speed Axle Switch - Switch signal which indicates the current axle range.

00 - Low speed range
 01 - High speed range

Bit Length: 2 bits
 Type: Measured
 Suspect Parameter Number: 69
 Parameter Group Number: [65265]

spn70 - Parking Brake Switch - Switch signal which indicates when the parking brake is set. In general the switch actuated by the operator's park brake control, whether a pedal, lever or other control mechanism. (See also SPN 619)

00 - Parking brake not set
 01 - Parking brake set

Bit Length: 2 bits
 Type: Measured
 Suspect Parameter Number: 70
 Parameter Group Number: [65265]

spn72 - Blower Bypass Valve Position - Relative position of the blower bypass valve.

Data Length: 1 byte
 Resolution: 0.4 %/bit , 0 offset
 Data Range: 0 to 100 %
 Type: Measured

Suspect Parameter Number: 72
 Parameter Group Number: [65277]

spn73 - Auxiliary Pump Pressure - Gage pressure of auxiliary water pump driven as a PTO device.

Data Length: 1 byte
 Resolution: 16 kPa/bit , 0 offset
 Data Range: 0 to 4000 kPa
 Type: Measured
 Suspect Parameter Number: 73
 Parameter Group Number: [65278]

spn74 - Maximum Vehicle Speed Limit - Maximum vehicle velocity allowed.

Data Length: 1 byte
 Resolution: 1 km/h per bit , 0 offset
 Data Range: 0 to 250 km/h
 Type: Measured
 Suspect Parameter Number: 74
 Parameter Group Number: [65261]

spn75 - Steering Axle Temperature - Temperature of lubricant in steering axle.

Data Length: 1 byte
 Resolution: 1 deg C/bit , -40 deg C offset
 Data Range: -40 to 210 deg C
 Type: Measured
 Suspect Parameter Number: 75
 Parameter Group Number: [65273]

spn79 - Road Surface Temperature - Indicated temperature of road surface over which vehicle is operating.

Data Length: 2 bytes
 Resolution: 0.03125 deg C/bit , -273 deg C offset
 Data Range: -273 to 1735 deg C
 Type: Measured
 Suspect Parameter Number: 79
 Parameter Group Number: [65269]

spn80 - Washer Fluid Level - Ratio of volume of liquid to total container volume of fluid reservoir in windshield wash system.

Data Length: 1 byte
 Resolution: 0.4 %/bit , 0 offset
 Data Range: 0 to 100 %
 Type: Measured
 Suspect Parameter Number: 80
 Parameter Group Number: [65276]

spn81 - Particulate Trap Inlet Pressure - Exhaust back pressure as a result of particle accumulation on filter media placed in the exhaust stream.

Data Length: 1 byte
 Resolution: 0.5 kPa/bit , 0 offset
 Data Range: 0 to 125 kPa
 Type: Measured
 Suspect Parameter Number: 81
 Parameter Group Number: [65270]

spn82 - Air Start Pressure - Gage pressure of air in an engine starting system that utilizes compressed air to provide the force required to rotate the crankshaft.

Data Length: 1 byte
 Resolution: 4 kPa/bit , 0 offset
 Data Range: 0 to 1000 kPa
 Type: Measured
 Suspect Parameter Number: 82
 Parameter Group Number: [65246]

spn84 - Wheel-Based Vehicle Speed - Speed of the vehicle as calculated from wheel or tailshaft speed.

Data Length: 2 bytes
 Resolution: 1/256 km/h per bit , 0 offset
 Data Range: 0 to 250.996 km/h
 Type: Measured
 Suspect Parameter Number: 84
 Parameter Group Number: [65265]

spn86 - Cruise Control Set Speed - Value of set (chosen) velocity of velocity control system.

Data Length: 1 byte
 Resolution: 1 km/h per bit , 0 offset
 Data Range: 0 to 250 km/h
 Type: Measured
 Suspect Parameter Number: 86
 Parameter Group Number: [65265]

spn87 - Cruise Control High Set Limit Speed - Maximum vehicle velocity at which cruise can be set.

Data Length: 1 byte
 Resolution: 1 km/h per bit , 0 offset
 Data Range: 0 to 250 km/h
 Type: Measured
 Suspect Parameter Number: 87
 Parameter Group Number: [65261]

spn88 - Cruise Control Low Set Limit Speed - Minimum vehicle velocity at which cruise can be set or minimum vehicle velocity for cruise operation before it will exit cruise control operation.

Data Length:	1 byte
Resolution:	1 km/h per bit , 0 offset
Data Range:	0 to 250 km/h
Type:	Measured
Suspect Parameter Number:	88
Parameter Group Number:	[65261]

spn90 - Power Takeoff Oil Temperature - Temperature of lubricant in device used to transmit engine power to auxiliary equipment.

Data Length:	1 byte
Resolution:	1 deg C/bit , -40 deg C offset
Data Range:	-40 to 210 deg C
Type:	Measured
Suspect Parameter Number:	90
Parameter Group Number:	[65264]

spn91 - Accelerator Pedal Position 1 - The ratio of actual position of the analog engine speed/torque request input device (such as an accelerator pedal or throttle lever) to the maximum position of the input device. This parameter is intended for the primary accelerator control in an application. If an application has only one accelerator control, use SPN 91. For on-highway vehicles, this will typically be the operator's accelerator pedal. Although it is used as an input to determine powertrain demand, it also provides anticipatory information to transmission and ASR algorithms about driver actions. In marine applications, this will typically be the operator's throttle lever. If a low idle validation switch is used in conjunction with accelerator pedal position 1, use Accelerator Pedal Low Idle Switch 1, SPN 558.

Data Length:	1 byte
Resolution:	0.4 %/bit , 0 offset
Data Range:	0 to 100 %
Type:	Measured
Suspect Parameter Number:	91
Parameter Group Number:	[61443]

spn92 - Percent Load At Current Speed - The ratio of actual engine percent torque (indicated) to maximum indicated torque available at the current engine speed, clipped to zero torque during engine braking.

Data Length:	1 byte
Resolution:	1 %/bit , 0 offset
Data Range:	0 to 250 %
Operating Range:	0 to 125%
Type:	Status
Suspect Parameter Number:	92
Parameter Group Number:	[61443]

spn94 - Fuel Delivery Pressure - Gage pressure of fuel in system as delivered from supply pump to the injection pump. See Figures SPN16_A & SPN16_B.

Data Length:	1 byte
Resolution:	4 kPa/bit , 0 offset

Data Range: 0 to 1000 kPa
 Type: Measured
 Suspect Parameter Number: 94
 Parameter Group Number: [65263]

spn95 - Fuel Filter Differential Pressure - Change in fuel delivery pressure, measured across the filter, due to accumulation of solid or semisolid matter on the filter element. See Figures SPN16_A & SPN16_B.

Data Length: 1 byte
 Resolution: 2 kPa/bit , 0 offset
 Data Range: 0 to 500 kPa
 Type: Measured
 Suspect Parameter Number: 95
 Parameter Group Number: [65276]

spn96 - Fuel Level - Ratio of volume of fuel to the total volume of fuel storage container.

Data Length: 1 byte
 Resolution: 0.4 %/bit , 0 offset
 Data Range: 0 to 100 %
 Type: Measured
 Suspect Parameter Number: 96
 Parameter Group Number: [65276]

spn97 - Water In Fuel Indicator - Signal which indicates the presence of water in the fuel.

00 - No
 01 - Yes

Bit Length: 2 bits
 Type: Measured
 Suspect Parameter Number: 97
 Parameter Group Number: [65279]

spn98 - Engine Oil Level - Ratio of current volume of engine sump oil to maximum required volume.

Data Length: 1 byte
 Resolution: 0.4 %/bit , 0 offset
 Data Range: 0 to 100 %
 Type: Measured
 Suspect Parameter Number: 98
 Parameter Group Number: [65263]

spn99 - Engine Oil Filter Differential Pressure - Change in engine oil pressure, measured across the filter, due to the filter and any accumulation of solid or semisolid material on or in the filter.

Data Length: 1 byte
 Resolution: 0.5 kPa/bit , 0 offset
 Data Range: 0 to 125 kPa
 Type: Measured
 Suspect Parameter Number: 99

Parameter Group Number: [65276]

spn100 - Engine Oil Pressure - Gage pressure of oil in engine lubrication system as provided by oil pump.

Data Length: 1 byte
 Resolution: 4 kPa/bit , 0 offset
 Data Range: 0 to 1000 kPa
 Type: Measured
 Suspect Parameter Number: 100
 Parameter Group Number: [65263]

spn101 - Crankcase Pressure - Gage pressure inside engine crankcase.

Data Length: 2 bytes
 Resolution: 1/128 kPa/bit , -250 kPa offset
 Data Range: -250 kPa TO 251.99 kPa
 Type: Measured
 Suspect Parameter Number: 101
 Parameter Group Number: [65263]

spn102 - Boost Pressure - Gage pressure of air measured downstream on the compressor discharge side of the turbocharger.

See also SPNs 1127-1130 for alternate range and resolution. If there is one boost pressure to report and this range and resolution is adequate, this parameter should be used.

Data Length: 1 byte
 Resolution: 2 kPa/bit , 0 offset
 Data Range: 0 to 500 kPa
 Type: Measured
 Suspect Parameter Number: 102
 Parameter Group Number: [65270]

spn103 - Turbocharger 1 Speed - Rotational velocity of rotor in the turbocharger.

Data Length: 2 bytes
 Resolution: 4 rpm/bit , 0 offset
 Data Range: 0 to 257,020 rpm
 Type: Measured
 Suspect Parameter Number: 103
 Parameter Group Number: [65245]

spn104 - Turbocharger Lube Oil Pressure 1 - Gage pressure of oil in turbocharger lubrication system.

Data Length: 1 byte
 Resolution: 4 kPa/bit , 0 offset
 Data Range: 0 to 1000 kPa
 Type: Measured
 Suspect Parameter Number: 104
 Parameter Group Number: [65245]

spn105 - Intake Manifold 1 Temperature - Temperature of pre-combustion air found in intake manifold of engine air supply system.

Data Length: 1 byte
 Resolution: 1 deg C/bit , -40 deg C offset
 Data Range: -40 to 210 deg C
 Type: Measured
 Suspect Parameter Number: 105
 Parameter Group Number: [65270]

spn106 - Air Inlet Pressure - Absolute air pressure at inlet to intake manifold or air box.

Data Length: 1 byte
 Resolution: 2 kPa/bit , 0 offset
 Data Range: 0 to 500 kPa
 Type: Measured
 Suspect Parameter Number: 106
 Parameter Group Number: [65270]

spn107 - Air Filter 1 Differential Pressure - Change in engine air system pressure, measured across the filter, due to the filter and any accumulation of solid foreign matter on or in the filter. This is the measurement of the first filter in a multiple air filter system. In a single air filter application, this is the only SPN used. Filter numbering follows the guidelines noted in section, Naming Convention For Engine Parameters.

Data Length: 1 byte
 Resolution: 0.05 kPa/bit , 0 offset
 Data Range: 0 to 12.5 kPa
 Type: Measured
 Suspect Parameter Number: 107
 Parameter Group Number: [65270]

spn108 - Barometric Pressure - Absolute air pressure of the atmosphere. See Figures SPN16_A & SPN16_B.

Data Length: 1 byte
 Resolution: 0.5 kPa/bit , 0 offset
 Data Range: 0 to 125 kPa
 Type: Measured
 Suspect Parameter Number: 108
 Parameter Group Number: [65269]

spn109 - Coolant Pressure - Gage pressure of liquid found in engine cooling system.

Data Length: 1 byte
 Resolution: 2 kPa/bit , 0 offset
 Data Range: 0 to 500 kPa
 Type: Measured
 Suspect Parameter Number: 109
 Parameter Group Number: [65263]

spn110 - Engine Coolant Temperature - Temperature of liquid found in engine cooling system.

Data Length: 1 byte
 Resolution: 1 deg C/bit , -40 deg C offset
 Data Range: -40 to 210 deg C
 Type: Measured
 Suspect Parameter Number: 110
 Parameter Group Number: [65262]

spn111 - Coolant Level - Ratio of volume of liquid found in engine cooling system to total cooling system volume. Typical monitoring location is in the coolant expansion tank.

Data Length: 1 byte
 Resolution: 0.4 %/bit , 0 offset
 Data Range: 0 to 100 %
 Type: Measured
 Suspect Parameter Number: 111
 Parameter Group Number: [65263]

spn112 - Coolant Filter Differential Pressure - Change in coolant pressure, measured across the filter, due to the filter and any accumulation of solid or semisolid matter on or in the filter.

Data Length: 1 byte
 Resolution: 0.5 kPa/bit , 0 offset
 Data Range: 0 to 125 kPa
 Type: Measured
 Suspect Parameter Number: 112
 Parameter Group Number: [65270]

spn114 - Net Battery Current - Net flow of electrical current into/out of the battery or batteries.

Data Length: 1 byte
 Resolution: 1 A/bit , -125 A offset
 Data Range: -125 to 125 A
 Type: Measured
 Suspect Parameter Number: 114
 Parameter Group Number: [65271]

spn115 - Alternator Current - Measure of electrical current flow from the alternator. Alternator Current (High Range/Resolution) parameter SPN 1795 has a higher range and resolution of the same parameter.

Data Length: 1 byte
 Resolution: 1 A/bit , 0 offset
 Data Range: 0 to 250 A
 Type: Measured
 Suspect Parameter Number: 115
 Parameter Group Number: [65271]

spn116 - Brake Application Pressure - Gage pressure of compressed air or fluid in vehicle braking system measured at

the brake chamber when brake shoe (or pad) is placed against brake drum (or disc).

Data Length: 1 byte
 Resolution: 4 kPa/bit , 0 offset
 Data Range: 0 to 1000 kPa
 Type: Measured
 Suspect Parameter Number: 116
 Parameter Group Number: [65274]

spn117 - Brake Primary Pressure - Gage pressure of air in the primary, or supply side, of the air brake system.

Data Length: 1 byte
 Resolution: 4 kPa/bit , 0 offset
 Data Range: 0 to 1000 kPa
 Type: Measured
 Suspect Parameter Number: 117
 Parameter Group Number: [65274]

spn118 - Brake Secondary Pressure - Gage pressure of air in the secondary, or service side, of the air brake system.

Data Length: 1 byte
 Resolution: 4 kPa/bit , 0 offset
 Data Range: 0 to 1000 kPa
 Type: Measured
 Suspect Parameter Number: 118
 Parameter Group Number: [65274]

spn119 - Hydraulic Retarder Pressure - Gage pressure of oil in hydraulic retarder system.

Data Length: 1 byte
 Resolution: 16 kPa/bit , 0 offset
 Data Range: 0 to 4000 kPa
 Type: Measured
 Suspect Parameter Number: 119
 Parameter Group Number: [65275]

spn120 - Hydraulic Retarder Oil Temperature - Temperature of oil found in a hydraulic retarder.

Data Length: 1 byte
 Resolution: 1 deg C/bit , -40 deg C offset
 Data Range: -40 to 210 deg C
 Type: Measured
 Suspect Parameter Number: 120
 Parameter Group Number: [65275]

spn123 - Clutch Pressure - Gage pressure of oil within a wet clutch.

Data Length: 1 byte
 Resolution: 16 kPa/bit , 0 offset
 Data Range: 0 to 4000 kPa

Type: Measured
 Suspect Parameter Number: 123
 Parameter Group Number: [65272]

spn124 - Transmission Oil Level - Ratio of volume of transmission sump oil to recommended volume.

Data Length: 1 byte
 Resolution: 0.4 %/bit , 0 offset
 Data Range: 0 to 100 %
 Type: Measured
 Suspect Parameter Number: 124
 Parameter Group Number: [65272]

spn126 - Transmission Filter Differential Pressure - Change in transmission fluid pressure, measured after the filter, due to accumulation of solid or semisolid material on or in the filter.

Data Length: 1 byte
 Resolution: 2 kPa/bit , 0 offset
 Data Range: 0 to 500 kPa
 Type: Measured
 Suspect Parameter Number: 126
 Parameter Group Number: [65272]

spn127 - Transmission Oil Pressure - Gage pressure of lubrication fluid in transmission, measured after pump.

Data Length: 1 byte
 Resolution: 16 kPa/bit , 0 offset
 Data Range: 0 to 4000 kPa
 Type: Measured
 Suspect Parameter Number: 127
 Parameter Group Number: [65272]

spn129 - Injector Metering Rail 2 Pressure (duplicate, use 1349) - The gage pressure of fuel in the metering rail #2 as delivered from the supply pump to the injector metering inlet. See Figure SPN16_A for fuel system related parameters. Although the figure does not show rail #2 it does show the relationship of rail pressure to other signals. (Obsolete - use SPN 1349)

Data Length: 2 bytes
 Resolution: 1/256 MPa/bit , 0 offset
 Data Range: 0 to 251 Mpa
 Type: Measured
 Suspect Parameter Number: 129
 Parameter Group Number: []

spn132 - Inlet Air Mass Flow Rate - Mass flow rate of fresh air entering the engine air intake, before any EGR mixer, if used. Flow rate of fresh air conducted to the engine cylinders to support combustion.

Data Length: 2 bytes
 Resolution: 0.05 kg/h per bit , 0 offset
 Data Range: 0 to 3212.75 kg/h

Type: Measured
 Suspect Parameter Number: 132
 Parameter Group Number: [61450]

spn136 - Auxiliary Vacuum Pressure Reading - Identifies the current vacuum pressure (relative to atmosphere) that is configured uniquely per application. Not to be used in place of defined parameters.

Data Length: 2 bytes
 Resolution: 0.5 kPa/bit , 0 offset
 Data Range: 0 to 32,127.5 kPa
 Type: Measured
 Suspect Parameter Number: 136
 Parameter Group Number: [65143]

spn137 - Auxiliary Gage Pressure Reading 1 - Identifies the current gage pressure (relative to atmosphere) that is configured uniquely per application. Not to be used in place of defined parameters.

Data Length: 2 bytes
 Resolution: 0.5 kPa/bit , 0 offset
 Data Range: 0 to 32,127.5 kPa
 Type: Measured
 Suspect Parameter Number: 137
 Parameter Group Number: [65143]

spn138 - Auxiliary Absolute Pressure Reading - Identifies the current absolute pressure (relative to 0 pressure) that is configured uniquely per application. Not to be used in place of defined parameters.

Data Length: 2 bytes
 Resolution: 0.5 kPa/bit , 0 offset
 Data Range: 0 to 32,127.5 kPa
 Type: Measured
 Suspect Parameter Number: 138
 Parameter Group Number: [65143]

spn141 - Trailer, Tag Or Push Channel Tire Pressure Target - The tire pressure control system's target gage pressure for the trailer, tag, or push group of tires.

Data Length: 2 bytes
 Resolution: 0.5 kPa/bit , 0 offset
 Data Range: 0 to 32,127.5 kPa
 Type: Measured
 Suspect Parameter Number: 141
 Parameter Group Number: [65145]

spn142 - Drive Channel Tire Pressure Target - The tire pressure control system's target gage pressure for the drive group of tires.

Data Length: 2 bytes
 Resolution: 0.5 kPa/bit , 0 offset

Data Range: 0 to 32,127.5 kPa
 Type: Measured
 Suspect Parameter Number: 142
 Parameter Group Number: [65145]

spn143 - Steer Channel Tire Pressure Target - The tire pressure control system's target gage pressure for the steer group of tires.

Data Length: 2 bytes
 Resolution: 0.5 kPa/bit , 0 offset
 Data Range: 0 to 32,127.5 kPa
 Type: Measured
 Suspect Parameter Number: 143
 Parameter Group Number: [65145]

spn144 - Trailer, Tag Or Push Channel Tire Pressure - The latest gage pressure reading of the trailer, tag, or push group of tires, as opposed to the pressure in each tire.

Data Length: 2 bytes
 Resolution: 0.5 kPa/bit , 0 offset
 Data Range: 0 to 32,127.5 kPa
 Type: Measured
 Suspect Parameter Number: 144
 Parameter Group Number: [65146]

spn145 - Drive Channel Tire Pressure - The latest gage pressure reading of the drive group of tires, as opposed to the pressure in each tire.

Data Length: 2 bytes
 Resolution: 0.5 kPa/bit , 0 offset
 Data Range: 0 to 32,127.5 kPa
 Type: Measured
 Suspect Parameter Number: 145
 Parameter Group Number: [65146]

spn146 - Steel Channel Tire Pressure - The latest gage pressure reading of the steer group of tires, as opposed to the pressure in each tire.

Data Length: 2 bytes
 Resolution: 0.5 kPa/bit , 0 offset
 Data Range: 0 to 32,127.5 kPa
 Type: Measured
 Suspect Parameter Number: 146
 Parameter Group Number: [65146]

spn156 - Injector Timing Rail 1 Pressure - The gage pressure of fuel in the timing rail delivered from the supply pump to the injector timing inlet. See Figure SPN16_A.

Data Length: 2 bytes

Resolution: 1/256 MPa/bit , 0 offset
 Data Range: 0 to 251 Mpa
 Type: Measured
 Suspect Parameter Number: 156
 Parameter Group Number: [65243]

spn157 - Injector Metering Rail 1 Pressure - The gage pressure of fuel in the primary, or first, metering rail as delivered from the supply pump to the injector metering inlet. See Figure SPN16_A.

Data Length: 2 bytes
 Resolution: 1/256 MPa/bit , 0 offset
 Data Range: 0 to 251 Mpa
 Type: Measured
 Suspect Parameter Number: 157
 Parameter Group Number: [65243]

spn158 - Battery Potential (Voltage), Switched - Electrical potential measured at the input of the electronic control unit supplied through a switching device.

Data Length: 2 bytes
 Resolution: 0.05 V/bit , 0 offset
 Data Range: 0 to 3212.75 V
 Type: Measured
 Suspect Parameter Number: 158
 Parameter Group Number: [65271]

spn159 - Gas Supply Pressure - Gage pressure of gas supply to fuel metering device.

Data Length: 2 bytes
 Resolution: 0.5 kPa/bit , 0 offset
 Data Range: 0 to 32,127.5 kPa
 Type: Measured
 Suspect Parameter Number: 159
 Parameter Group Number: [65277]

spn160 - Main Shaft Speed - Rotational velocity of the first intermediate shaft of the transmission.

Data Length: 2 bytes
 Resolution: 0.125 rpm/bit , 0 offset
 Data Range: 0 to 8,031.875 rpm
 Type: Measured
 Suspect Parameter Number: 160
 Parameter Group Number: []

spn161 - Input Shaft Speed - Rotational velocity of the primary shaft transferring power into the transmission. When a torque converter is present, it is the output of the torque converter.

Data Length: 2 bytes
 Resolution: 0.125 rpm/bit , 0 offset

Data Range: 0 to 8,031.875 rpm
 Type: Measured
 Suspect Parameter Number: 161
 Parameter Group Number: [61442]

spn162 - Transmission Requested Range - Range selected by the operator. Characters may include P, Rx, Rx-1...R2, R1, R, Nx, Nx-1...N2, N1, N, D, D1, D2..., Dx, L, L1, L2..., Lx-1, 1, 2, 3,... If only one displayed character is required, the second character shall be used and the first character shall be a space (ASCII 32) or a control character (ASCII 0 to 31). If the first character is a control character, refer to the manufacturer's application document for definition.

Data Length: 2 bytes
 Resolution: ASCII , 0 offset
 Data Range: 0 to 255 per byte
 Type: Status
 Suspect Parameter Number: 162
 Parameter Group Number: [61445]

spn163 - Transmission Current Range - Range currently being commanded by the transmission control system. Characters may include P, Rx, Rx-1...R2, R1, R, Nx, Nx-1...N2, N1, N, D, D1, D2..., Dx, L, L1, L2..., Lx-1, 1, 2, 3,... If only one displayed character is required, the second character shall be used and the first character shall be a space (ASCII 32) or a control character (ASCII 0 to 31). If the first character is a control character, refer to the manufacturer's application document for definition.

Data Length: 2 bytes
 Resolution: ASCII , 0 offset
 Data Range: 0 to 255 per byte
 Type: Status
 Suspect Parameter Number: 163
 Parameter Group Number: [61445]

spn164 - Injection Control Pressure - The gage pressure of the engine oil in the hydraulic accumulator that powers an intensifier used for fuel injection.

Data Length: 2 bytes
 Resolution: 1/256 MPa/bit , 0 offset
 Data Range: 0 to 251 Mpa
 Type: Measured
 Suspect Parameter Number: 164
 Parameter Group Number: [65243]

spn165 - Compass Bearing - Present compass bearing of vehicle.

Data Length: 2 bytes
 Resolution: 1/128 deg/bit , 0 offset
 Data Range: 0 to 501.99 deg
 Type: Measured
 Suspect Parameter Number: 165
 Parameter Group Number: [65256]

spn166 - Rated Engine Power - Net brake power that the engine will deliver continuously, specified for a given application at a rated speed.

Data Length: 2 bytes
 Resolution: 0.5 kW/bit , 0 offset
 Data Range: 0 to 32,127.5 kW
 Type: Measured
 Suspect Parameter Number: 166
 Parameter Group Number: [65214]

spn167 - Alternator Potential (Voltage) - Electrical potential measured at the alternator output.

Data Length: 2 bytes
 Resolution: 0.05 V/bit , 0 offset
 Data Range: 0 to 3212.75 V
 Type: Measured
 Suspect Parameter Number: 167
 Parameter Group Number: [65271]

spn168 - Electrical Potential (Voltage) - Measured electrical potential of the battery.

Data Length: 2 bytes
 Resolution: 0.05 V/bit , 0 offset
 Data Range: 0 to 3212.75 V
 Type: Measured
 Suspect Parameter Number: 168
 Parameter Group Number: [65271]

spn169 - Cargo Ambient Temperature - Temperature of air inside vehicle container used to accommodate cargo.

Data Length: 2 bytes
 Resolution: 0.03125 deg C/bit , -273 deg C offset
 Data Range: -273 to 1735 deg C
 Type: Measured
 Suspect Parameter Number: 169
 Parameter Group Number: [65276]

spn170 - Cab Interior Temperature - Temperature of air inside the part of the vehicle that encloses the driver and vehicle operating controls. Note: See SPN 1662 and SPN 1691.

Data Length: 2 bytes
 Resolution: 0.03125 deg C/bit , -273 deg C offset
 Data Range: -273 to 1735 deg C
 Type: Measured
 Suspect Parameter Number: 170
 Parameter Group Number: [65269]

spn171 - Ambient Air Temperature - Temperature of air surrounding vehicle.

Data Length: 2 bytes

Resolution: 0.03125 deg C/bit , -273 deg C offset
 Data Range: -273 to 1735 deg C
 Type: Measured
 Suspect Parameter Number: 171
 Parameter Group Number: [65269]

spn172 - Air Inlet Temperature - Temperature of air entering vehicle air induction system.

Data Length: 1 byte
 Resolution: 1 deg C/bit , -40 deg C offset
 Data Range: -40 to 210 deg C
 Type: Measured
 Suspect Parameter Number: 172
 Parameter Group Number: [65269]

spn173 - Exhaust Gas Temperature - Temperature of combustion byproducts leaving the engine. See SPNs 2433 and 2434 for engines with more than one exhaust gas temperature measurement.

Data Length: 2 bytes
 Resolution: 0.03125 deg C/bit , -273 deg C offset
 Data Range: -273 to 1735 deg C
 Type: Measured
 Suspect Parameter Number: 173
 Parameter Group Number: [65270]

spn174 - Fuel Temperature - Temperature of fuel entering injectors.

Data Length: 1 byte
 Resolution: 1 deg C/bit , -40 deg C offset
 Data Range: -40 to 210 deg C
 Type: Measured
 Suspect Parameter Number: 174
 Parameter Group Number: [65262]

spn175 - Engine Oil Temperature 1 - Temperature of the engine lubricant.

Data Length: 2 bytes
 Resolution: 0.03125 deg C/bit , -273 deg C offset
 Data Range: -273 to 1735 deg C
 Type: Measured
 Suspect Parameter Number: 175
 Parameter Group Number: [65262]

spn176 - Turbo Oil Temperature - Temperature of the turbocharger lubricant.

Data Length: 2 bytes
 Resolution: 0.03125 deg C/bit , -273 deg C offset
 Data Range: -273 to 1735 deg C
 Type: Measured

Suspect Parameter Number: 176
 Parameter Group Number: [65262]

spn177 - Transmission Oil Temperature - Temperature of the transmission lubricant.

Data Length: 2 bytes
 Resolution: 0.03125 deg C/bit , -273 deg C offset
 Data Range: -273 to 1735 deg C
 Type: Measured
 Suspect Parameter Number: 177
 Parameter Group Number: [65272]

spn180 - Trailer Weight - Total mass of freight-carrying vehicle designed to be pulled by truck, including the weight of the contents.

Data Length: 2 bytes
 Resolution: 2 kg/bit , 0 offset
 Data Range: 0 to 128,510 kg
 Type: Measured
 Suspect Parameter Number: 180
 Parameter Group Number: [65258]

spn181 - Cargo Weight - The mass of freight carried.

Data Length: 2 bytes
 Resolution: 2 kg/bit , 0 offset
 Data Range: 0 to 128,510 kg
 Type: Measured
 Suspect Parameter Number: 181
 Parameter Group Number: [65258]

spn182 - Trip Fuel - Fuel consumed during all or part of a journey.

Data Length: 4 bytes
 Resolution: 0.5 L/bit , 0 offset
 Data Range: 0 to 2,105,540,607.5 L
 Type: Measured
 Suspect Parameter Number: 182
 Parameter Group Number: [65257]

spn183 - Fuel Rate - Amount of fuel consumed by engine per unit of time.

Data Length: 2 bytes
 Resolution: 0.05 L/h per bit , 0 offset
 Data Range: 0 to 3,212.75 L/h
 Type: Measured
 Suspect Parameter Number: 183
 Parameter Group Number: [65266]

spn184 - Instantaneous Fuel Economy - Current fuel economy at current vehicle velocity.

Data Length: 2 bytes
 Resolution: 1/512 km/kg per bit , 0 offset
 Data Range: 0 to 125.5 km/kg
 Type: Measured
 Suspect Parameter Number: 184
 Parameter Group Number: [65266]

spn185 - Average Fuel Economy - Average of instantaneous fuel economy for that segment of vehicle operation of interest.

Data Length: 2 bytes
 Resolution: 1/512 km/kg per bit , 0 offset
 Data Range: 0 to 125.5 km/kg
 Type: Measured
 Suspect Parameter Number: 185
 Parameter Group Number: [65266]

spn186 - Power Takeoff Speed - Rotational velocity of device used to transmit engine power to auxiliary equipment.

Data Length: 2 bytes
 Resolution: 0.125 rpm/bit , 0 offset
 Data Range: 0 to 8,031.875 rpm
 Type: Measured
 Suspect Parameter Number: 186
 Parameter Group Number: [65264]

spn187 - Power Takeoff Set Speed - Rotational velocity selected by operator for device used to transmit engine power to auxiliary equipment.

Data Length: 2 bytes
 Resolution: 0.125 rpm/bit , 0 offset
 Data Range: 0 to 8,031.875 rpm
 Type: Measured
 Suspect Parameter Number: 187
 Parameter Group Number: [65264]

spn188 - Engine Speed At Idle, Point 1 (Engine Configuration) - Stationary low idle speed of engine which includes influences due to engine temperature (after power up) and other stationary changes (calibration offsets, sensor failures, etc). This parameter is point 1 of the engine configuration map (see PGN 65251).

Data Length: 2 bytes
 Resolution: 0.125 rpm/bit , 0 offset
 Data Range: 0 to 8,031.875 rpm
 Type: Measured
 Suspect Parameter Number: 188
 Parameter Group Number: [65251]

spn189 - Rated Engine Speed - The maximum governed rotational velocity of the engine crankshaft under full load

conditions. Note that the engine speed at point 2 (SPN 528) is equal to rated engine speed only in the case when the engine has not been derated. Please also reference PGN 65251.

Data Length:	2 bytes
Resolution:	0.125 rpm/bit , 0 offset
Data Range:	0 to 8,031.875 rpm
Type:	Measured
Suspect Parameter Number:	189
Parameter Group Number:	[65214]

spn190 - Engine Speed - Actual engine speed which is calculated over a minimum crankshaft angle of 720 degrees divided by the number of cylinders.

Data Length:	2 bytes
Resolution:	0.125 rpm/bit , 0 offset
Data Range:	0 to 8,031.875 rpm
Type:	Measured
Suspect Parameter Number:	190
Parameter Group Number:	[61444]

spn191 - Output Shaft Speed - Calculated speed of the transmission output shaft.

Data Length:	2 bytes
Resolution:	0.125 rpm/bit , 0 offset
Data Range:	0 to 8,031.875 rpm
Type:	Measured
Suspect Parameter Number:	191
Parameter Group Number:	[61442]

spn233 - Unit Number (Power Unit) - Owner assigned unit number for the power unit of the vehicle. NOTE: The ASCII character "*" is reserved as a delimiter.

Data Length:	Variable - up to 200 characters ("*" delimited)
Resolution:	ASCII , 0 offset
Data Range:	0 to 255 per byte
Type:	Measured
Suspect Parameter Number:	233
Parameter Group Number:	[65259]

spn234 - Software Identification - Software identification of an electronic module. As an example, this parameter may be represented with ASCII characters MMDDYYaa where MM is the month, DD is the day, YY is the year, and aa is the revision number. NOTE The ASCII character "*" is reserved as a delimiter.

Data Length:	Variable - up to 200 characters ("*" delimited)
Resolution:	ASCII , 0 offset
Data Range:	0 to 255 per byte
Type:	Measured
Suspect Parameter Number:	234
Parameter Group Number:	[65242]

spn235 - Total Idle Hours - Accumulated time of operation of the engine while under idle conditions.

Data Length: 4 bytes
 Resolution: 0.05 hr/bit , 0 offset
 Data Range: 0 to 210,554,060.75 hr
 Type: Measured
 Suspect Parameter Number: 235
 Parameter Group Number: [65244]

spn236 - Total Idle Fuel Used - Accumulated amount of fuel used during vehicle operation while under idle conditions.

Data Length: 4 bytes
 Resolution: 0.5 L/bit , 0 offset
 Data Range: 0 to 2,105,540,607.5 L
 Type: Measured
 Suspect Parameter Number: 236
 Parameter Group Number: [65244]

spn237 - Vehicle Identification Number - Vehicle Identification Number (VIN) as assigned by the vehicle manufacturer.

NOTE The ASCII character "*" is reserved as a delimiter.

Data Length: Variable - up to 200 characters ("*" delimited)
 Resolution: ASCII , 0 offset
 Data Range: 0 to 255 per byte
 Type: Measured
 Suspect Parameter Number: 237
 Parameter Group Number: [65260]

spn241 - Tire Pressure - Pressure at which air is contained in cavity formed by tire and rim.

Data Length: 1 byte
 Resolution: 4 kPa/bit , 0 offset
 Data Range: 0 to 1000 kPa
 Type: Measured
 Suspect Parameter Number: 241
 Parameter Group Number: [65268]

spn242 - Tire Temperature - Temperature at the surface of the tire sidewall.

Data Length: 2 bytes
 Resolution: 0.03125 deg C/bit , -273 deg C offset
 Data Range: -273 to 1735 deg C
 Type: Measured
 Suspect Parameter Number: 242
 Parameter Group Number: [65268]

spn244 - Trip Distance - Distance traveled during all or part of a journey. NOTE See SPN 918 for alternate resolution.

Data Length: 4 bytes
 Resolution: 0.125 km/bit , 0 offset

Data Range: 0 to 526,385,151.9 km
 Type: Measured
 Suspect Parameter Number: 244
 Parameter Group Number: [65248]

spn245 - Total Vehicle Distance - Accumulated distance traveled by vehicle during its operation. NOTE See SPN 917 for alternate resolution.

Data Length: 4 bytes
 Resolution: 0.125 km/bit , 0 offset
 Data Range: 0 to 526,385,151.9 km
 Type: Measured
 Suspect Parameter Number: 245
 Parameter Group Number: [65248]

spn246 - Total Vehicle Hours - Accumulated time of operation of vehicle.

Data Length: 4 bytes
 Resolution: 0.05 hr/bit , 0 offset
 Data Range: 0 to 210,554,060.75 hr
 Type: Measured
 Suspect Parameter Number: 246
 Parameter Group Number: [65255]

spn247 - Total Engine Hours - Accumulated time of operation of engine.

Data Length: 4 bytes
 Resolution: 0.05 hr/bit , 0 offset
 Data Range: 0 to 210,554,060.75 hr
 Type: Measured
 Suspect Parameter Number: 247
 Parameter Group Number: [65253]

spn248 - Total Power Takeoff Hours - Accumulated time of operation of power takeoff device.

Data Length: 4 bytes
 Resolution: 0.05 hr/bit , 0 offset
 Data Range: 0 to 210,554,060.75 hr
 Type: Measured
 Suspect Parameter Number: 248
 Parameter Group Number: [65255]

spn249 - Total Engine Revolutions - Accumulated number of revolutions of engine crankshaft during its operation.

Data Length: 4 bytes
 Resolution: 1000 r/bit , 0 offset
 Data Range: 0 to 4,211,081,215,000 r
 Type: Measured
 Suspect Parameter Number: 249

Parameter Group Number: [65253]

spn250 - Total Fuel Used - Accumulated amount of fuel used during vehicle operation.

Data Length: 4 bytes
 Resolution: 0.5 L/bit , 0 offset
 Data Range: 0 to 2,105,540,607.5 L
 Type: Measured
 Suspect Parameter Number: 250
 Parameter Group Number: [65257]

spn411 - Exhaust Gas Recirculation Differential Pressure - Differential pressure across the Exhaust Gas Recirculation (EGR) system

Data Length: 2 bytes
 Resolution: 1/128 kPa/bit , -250 kPa offset
 Data Range: -250 kPa TO 251.99 kPa
 Type: Measured
 Suspect Parameter Number: 411
 Parameter Group Number: [65188]

spn412 - Exhaust Gas Recirculation Temperature - Temperature of Recirculated Exhaust Gas

Data Length: 2 bytes
 Resolution: 0.03125 deg C/bit , -273 deg C offset
 Data Range: -273 to 1735 deg C
 Type: Measured
 Suspect Parameter Number: 412
 Parameter Group Number: [65188]

spn441 - Auxiliary Temperature 1 - Temperature measured by auxiliary temperature sensor #1. Not to be used in place of existing SPNs.

Data Length: 1 byte
 Resolution: 1 deg C/bit , -40 deg C offset
 Data Range: -40 to 210 deg C
 Type: Measured
 Suspect Parameter Number: 441
 Parameter Group Number: [65164]

spn442 - Auxiliary Temperature 2 - Temperature measured by auxiliary temperature sensor #2. Not to be used in place of existing SPNs.

Data Length: 1 byte
 Resolution: 1 deg C/bit , -40 deg C offset
 Data Range: -40 to 210 deg C
 Type: Measured
 Suspect Parameter Number: 442
 Parameter Group Number: [65164]

spn444 - Battery 2 Potential (Voltage) - The voltage for isolated battery #2.

Data Length: 2 bytes
 Resolution: 0.05 V/bit , 0 offset
 Data Range: 0 to 3212.75 V
 Type: Measured
 Suspect Parameter Number: 444
 Parameter Group Number: [65165]

spn512 - Driver's Demand Engine - Percent Torque - The requested torque output of the engine by the driver. It is based on input from the following requestors external to the powertrain: operator (via the accelerator pedal), cruise control and/or road speed limit governor. Dynamic commands from internal powertrain functions such as smoke control, low- and high-speed engine governing; ASR and shift control are excluded from this calculation. The data is transmitted in indicated torque as a percent of the reference engine torque. See PGN 65251 for the engine configuration message. Several status bits are defined separately to indicate the request which is currently being honored. This parameter may be used for shift scheduling.

Data Length: 1 byte
 Resolution: 1 %/bit , -125% offset
 Data Range: -125 to 125 %
 Operating Range: 0 to 125%
 Type: Measured
 Suspect Parameter Number: 512
 Parameter Group Number: [61444]

Figure SPN512_A and Figure SPN512_B show two typical torque calculations in an engine controller. On the left side of the figures there are single engine controller functions. The output torque signals of these functions are connected in the manner shown. The result is the actual engine percent torque which is realized by the engine.

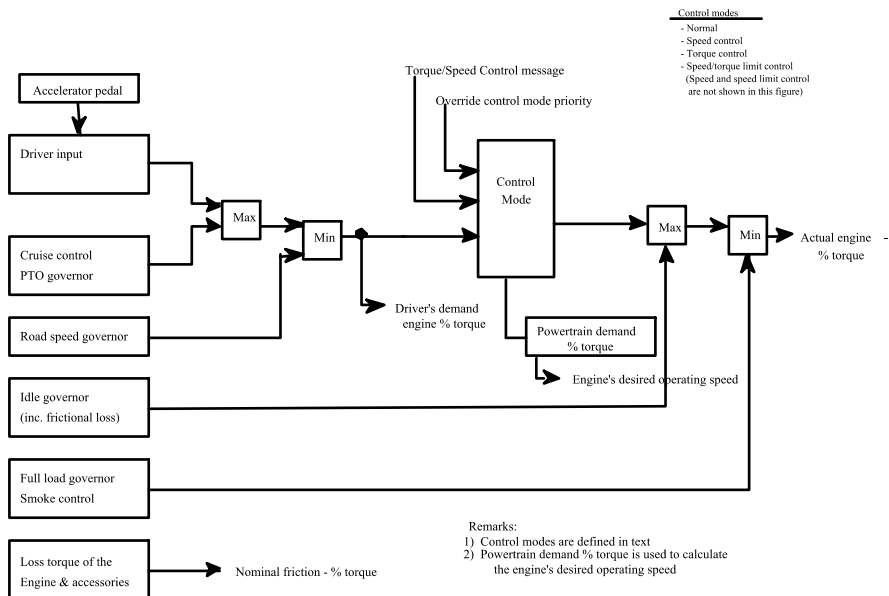
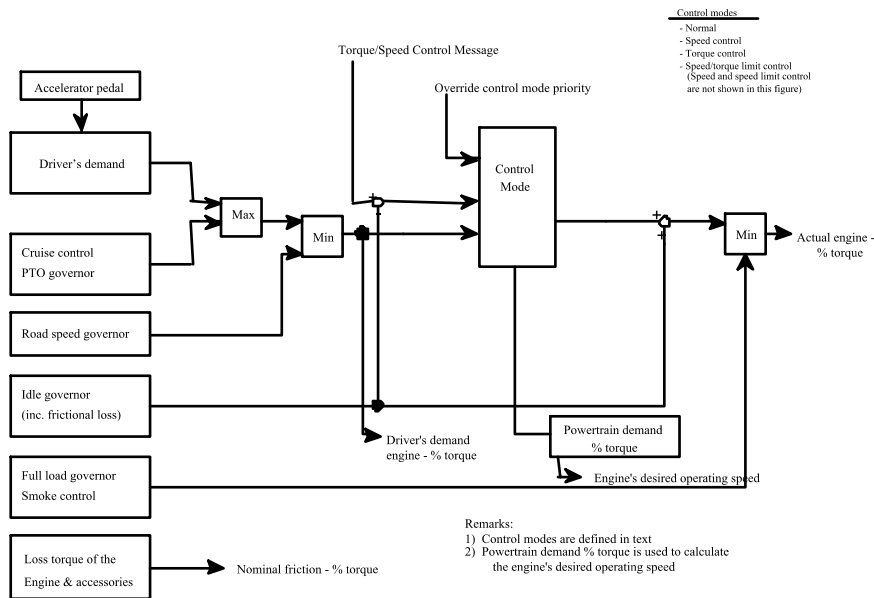

FIGURE SPN512_A -- TORQUE COMMANDS AND CALCULATIONS WHEN A 'MAXIMUM SELECTION FOR LOW

IDLE' TECHNIQUE IS USED



On top of the figures, external torque commands (e.g., traction and transmission control) can control the engine. These commands can influence the engine torque by four control modes. Four engine internal signals are transmitted to the network:

- Driver's demand engine - percent torque
- Actual engine - percent torque
- Nominal friction - percent torque
- Engine's desired operating speed

The difference between Figure SPN512_A and Figure SPN512_B is the connection of the idle governor output to the torque calculation. In Figure SPN512_A there is a maximum selection, while in Figure SPN512_B a summation is used. The summation method needs a subtraction point for each external command input because the starting point of an ASR or a shift operation should be the present actual engine - percent torque value. As the actual engine - percent torque signal contains the idle governor output and the external commands are compared with the driver's demand engine - percent torque or the powertrain demand which don't contain the idle governor output, the external commands must be subtracted by the idle governor output to get the correct signals for comparison.

The advantage of the maximum selection (Figure SPN512_A) is that no other speed controller can work parallel to the idle governor. This allows for a better optimization of the different speed control loops. The advantage of the summation method (Figure SPN512_B) is that changes of the idle governor output influence the engine directly (no dead zones exist).

FIGURE SPN512_B -- TORQUE COMMANDS AND CALCULATIONS WHEN A 'SUMMATION WITH LOW IDLE' TECHNIQUE IS USED

spn513 - Actual Engine - Percent Torque - The calculated output torque of the engine. The data is transmitted in indicated torque as a percent of reference engine torque (see the engine configuration message, PGN 65251). The engine percent torque value will not be less than zero and it includes the torque developed in the cylinders required to overcome friction.

Data Length: 1 byte
 Resolution: 1 %/bit , -125% offset

Data Range: -125 to 125 %
 Operating Range: 0 to 125%
 Type: Measured
 Suspect Parameter Number: 513
 Parameter Group Number: [61444]

spn514 - Nominal Friction - Percent Torque - The calculated torque that indicates the amount of torque required by the basic engine itself added by the loss torque of accessories. It contains the frictional and thermodynamic loss of the engine itself, and the losses of fuel, oil and cooling pumps. The data is transmitted in indicated torque as a percent of reference engine torque (see the engine configuration message, PGN 65251). The realization can be done by a map dependent on engine speed and engine temperature and an offset value for additional loss torques. See SPN 2978 for an indicator that describes the possible inclusion of engine parasitic losses such as cooling fan, etc. in this parameter value.

Data Length: 1 byte
 Resolution: 1 %/bit , -125% offset
 Data Range: -125 to 125 %
 Operating Range: 0 to 125%
 Type: Status
 Suspect Parameter Number: 514
 Parameter Group Number: [65247]

spn515 - Engine's Desired Operating Speed - An indication by the engine of the optimal operating speed of the engine for the current existing conditions. These conditions may include the torque generated to accommodate powertrain demands from the operator (via the accelerator pedal), cruise control, road speed limit governors, or ASR. Dynamic commands from functions such as smoke control or shift control are excluded from this calculation.

Data Length: 2 bytes
 Resolution: 0.125 rpm/bit , 0 offset
 Data Range: 0 to 8,031.875 rpm
 Operating Range: (upper byte resolution = 32 rpm/bit)
 Type: Status
 Suspect Parameter Number: 515
 Parameter Group Number: [65247]

spn516 - Ground-Based Vehicle Speed - Actual ground speed of the vehicle, measured by a device such as RADAR.
 (1.609344 km/h = 1 mph)

Data Length: 2 bytes
 Resolution: 1/256 km/h per bit , 0 offset
 Data Range: 0 to 250.996 km/h
 Type: Measured
 Suspect Parameter Number: 516
 Parameter Group Number: []

spn517 - Navigation-Based Vehicle Speed - Speed of the vehicle as calculated from a device such as a Global Positioning System (GPS).

Data Length: 2 bytes
 Resolution: 1/256 km/h per bit , 0 offset

Data Range: 0 to 250.996 km/h
 Type: Measured
 Suspect Parameter Number: 517
 Parameter Group Number: [65256]

spn518 - Requested Torque/Torque Limit - Parameter provided to the engine or retarder in the torque/speed control message for controlling or limiting the output torque. Requested torque to the engine is measured in indicated torque as a percentage of reference engine torque (see the engine configuration message, PGN 65251). This is the engine torque at which the engine is expected to operate if the torque control mode is active or the engine torque which the engine is not expected to exceed if the torque limit mode is active. Zero torque can be requested which implies zero fuel and, according to Figures SPN512_A and SPN512_B, the engine will not be allowed to stall. The actual engine percent torque (SPN 513) should be zero and the engine should decelerate until the low idle governor kicks in, at which time the actual engine percent torque will be calculated as shown in Figures SPN512_A and SPN512_B and the engine torque mode bits (SPN 899) should be equal to 0000b - Low Idle Governor. Requested torque to the retarder is measured in indicated torque as a percentage of reference retarder torque (see the retarder configuration message, PGN 65249). The logic used in enabling or disabling the retarder is based on the override control mode priority bits (SPN 897). A zero torque request to the retarder is a disable request, and is used by a J1939 node to prevent the retarder from being activated by other combinations of inputs outside of J1939 commands. The Torque Limit Mode is commonly used for this purpose.

Data Length: 1 byte
 Resolution: 1 %/bit , -125% offset
 Data Range: -125 to 125 %
 Operating Range: 0 to 125% engine torque requests, -125% to 0% for retarder torque requests
 Type: Status
 Suspect Parameter Number: 518
 Parameter Group Number: [0]

When preparing to send a request to a retarder, the states of the Retarder Enable-Shift Assist Switch and the Retarder Enable-Brake Assist Switch must be checked by the requesting device to determine whether the request may be sent to the Retarder. Figure SPN518_A shows how those switches and other operator and network inputs are used to create the actual retarder operating point on a system-wide basis. The Retarder may or may not be the device reading the actual switches; even if it is, it will not accept or reject a request based on its knowledge of the switch states. Its function is to send the switch states via J1939 (in its ERC1 message) and it expects other J1939 nodes to honor those switch states by refraining from sending inappropriate commands.

Several elements affect the retarder besides the Requested Torque parameter in the TSC1 message. These elements are not looked at by the retarder itself, but are used by various other devices to determine if they may ask the retarder to be engaged. These are the Retarder Enable Shift Assist Switch, and the Retarder Enable Brake Assist Switch. The relationship between those switches and the retarder (as well as that between the operator and retarder) is described in Figure SPN518_A.

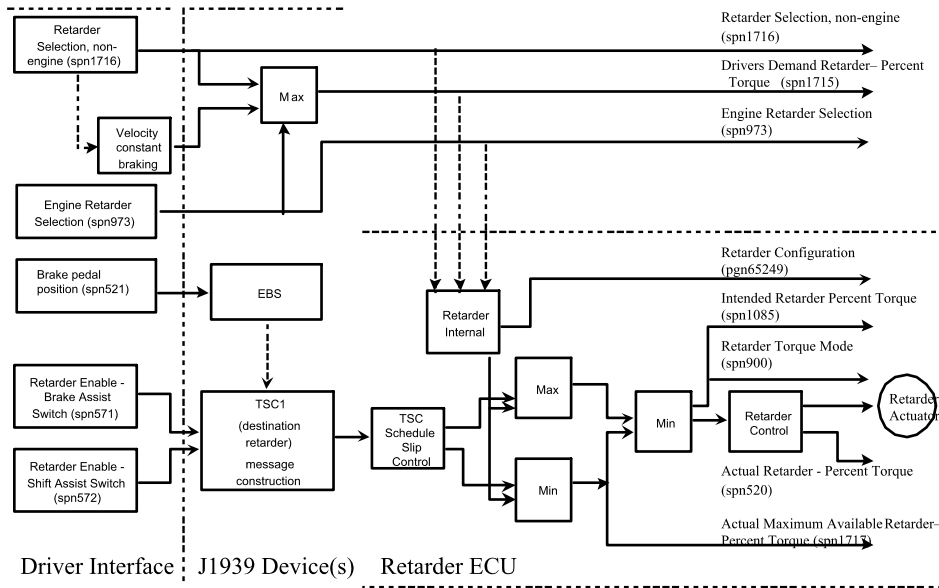

FIGURE SPN518_A -- RELATIONSHIP BETWEEN OPERATOR/SWITCH INPUTS AND RETARDERS

Tables SPN518_A and SPN518_B identify many use cases. Each row is the summary of one or more uses. One of the primary communications provided by these tables is that the retarder can be activated by the J1939 TSC1 message, although the operator input is "off."

J1939 Inputs ¹ (TSC1)	Operator Inputs			Outputs	
	Cruise Control ²	Accel Pedal ³	Torque Request Via "Retarder Selection, Engine" ⁴ (See 5.2.1.58)	May Retarder Provide Brake Torque?	Retarder Torque Mode (base 2)
T	Any	Any	Any	No	000 0
R	Any	Any	Any	Yes	> 0001
NTR	Any	T	Any	No	000 0
NTR	R	ZR	R	Yes	> 0001
NTR	R	ZR	ZR	Yes	001 0
NTR	NTR	ZR	R ⁵	Yes ⁵	000 1
NTR	NTR	ZR	ZR	No	000 0
ZR	Any	Any	Any	No	000 0

Key:

T = request positive Torque

R = request Retarder torque

NTR = No Torque Request

ZR = Zero torque Requested by retarder

Any = This value has no bearing whether or not the Retarder is available. The retarder will NOT be available because some other entity is requesting positive torque.

Footnotes:

1. Note that the TSC1 inputs will override Operator Torque Selection. The J1939 devices that generate the TSC1 messages will assure that the Retarder Enable Brake Assist Switch and Retarder Enable Shift Assist Switch are enabled as appropriate before commanding the Retarder to engage. See parameters SPN 571 and 572 for descriptions of these switches. Also, for the purposes of this table, it is assumed that if the TSC1, Destination Retarder message is requesting Retarder Torque, no other TSC1, Destination Engine messages are requesting engine fueling. That arbitration is beyond the scope of this section.

2. This refers to the torque requested by the cruise control, and does not refer to the cruise switches.

Cruise control is defined to be on and engaged in this column. The cruise control should not request retarder torque unless the Retarder Enable-Brake Assist Switch is enabled.

3. The Accelerator Pedal is inherently incapable of requesting negative torque. It may have no particular torque demands, or it may request some engine fueling, which prevents the retarder from engaging. Consequently, the chart is complete even though no rows exist for the AP to request retarder torque.

4. The Operator Torque Request is incapable of requesting positive torque. The table is complete without the Operator Torque Request asking for positive Engine Torque

5. This description assumes no other switch (such as brake pedal depressed) is needed in order for the operator torque request to initiate retarder braking. Other implementation specific rules would apply if such a catalyst were needed.

Table SPN518_B shows the relationship between various inputs and an after engine retarder.

The biggest difference between this type of retarder and an engine brake is that the exhaust brake may be engaged while the engine is still being fueled. Also, if cruise control is communicating with the retarder, it would do so using the TSC1 message.

Consequently, columns for accelerator pedal input and cruise control input would only serve to confuse the issue of retarder availability in Table SPN518_B.

TABLE SPN518_A -- PRIMARY RETARDER BEFORE TRANSMISSION (Compression Release Engine Retarder)

Operator Inputs		Outputs	
J1939 Inputs ₁ (TSC1)	Torque Request Via operator torque request ²	May Retarder Provide Brake Torque?	Retarder Torque Mode (base 2)
R	R	Yes	> 0001
R	ZR	Yes	> 0001
NTR	R ³	Yes ³	0001
NTR	ZR	No	0000
ZR	Any	No	0000

Key:

R = request Retarder torque- some amount of braking torque is requested of the retarder.

ZR = Zero Retarder request- Zero percent torque is requested of the retarder

NTR = No retarder Torque Request - No request is being made of the retarder one way or another.

Any = This value has no bearing whether or not the retarder is available. In fact, because of what some other entity is requesting, the retarder will NOT be available.

Footnotes:

1. Note that the TSC1 inputs will override Operator Torque Selection. The J1939 devices that generate the TSC1 messages will assure that the Retarder Enable Brake Assist Switch and Retarder Enable Shift Assist Switch are enabled before commanding the Retarder to engage. Also, for the purposes of this table, it is assumed that the TSC1, Destination Retarder message is requesting Retarder Torque, no other TSC1, Destination Engine messages are requesting engine fueling. That arbitration is beyond the scope of this section.

2. The Operator Torque Request is incapable of requesting positive torque. The table is complete without the Operator Torque Request asking for positive Engine Torque

3. This description assumes no other switch (such as brake pedal depressed) is needed in order for the operator torque request to initiate retarder braking. Other implementation specific rules would apply if such a requirement were needed.

TABLE SPN518_B -- PRIMARY RETARDER AFTER ENGINE (EXHAUST BRAKE, HYDRAULIC RETARDER)

spn519 - Engine's Desired Operating Speed Asymmetry Adjustment - This byte is utilized in transmission gear selection routines and indicates the engine's preference of lower versus higher engine speeds should its desired speed not be achievable. This is a scaled ratio such that 125 represents an equal preference for a speed lower or higher than the engine's indicated desired speed. The higher the asymmetry adjustment value is above 125, the more the engine prefers to be operated at or above its indicated desired speed. Conversely, the lower the asymmetry adjustment value is below 125, the more the engine prefers to operate at or below its indicated desired speed. Typically, the engine's asymmetry adjustment will be predicated on fuel consumption considerations, and under these conditions, the method for computing the asymmetry adjustment is indicated in Figure SPN519_A. The engine may include other factors into its asymmetry adjustment calculation such as temperatures, pressures, and other operating parameters.

Data Length: 1 byte
 Resolution: 1/bit , 0 offset
 Data Range: 0 to 250
 Type: Status
 Suspect Parameter Number: 519

Parameter Group Number: [65247]

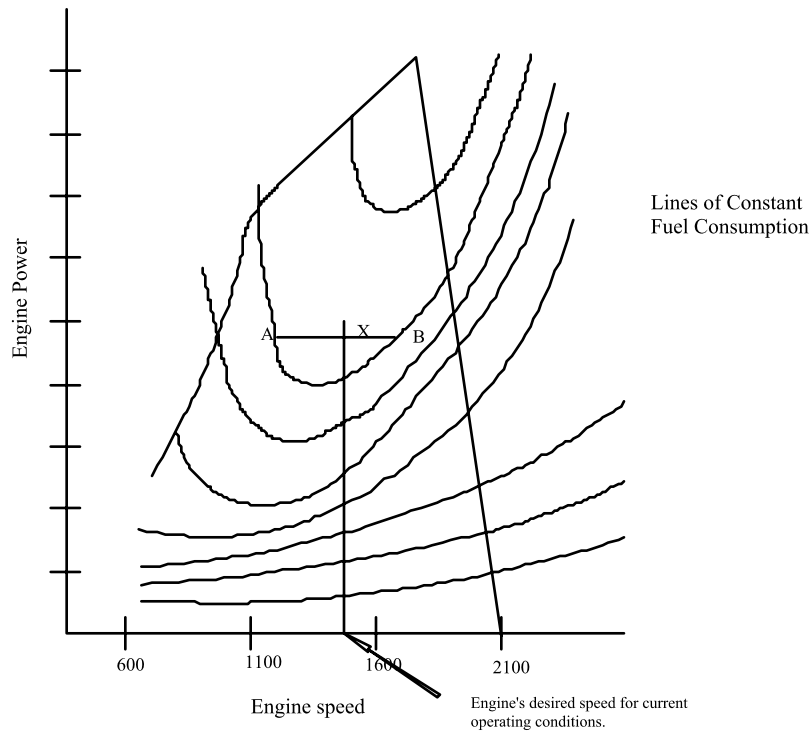

FIGURE SPN519_A -- DESIRED OPERATING SPEED ASYMMETRY ADJUSTMENT

spn520 - Actual Retarder - Percent Torque - Actual braking torque of the retarder as a percent of retarder configuration reference torque SPN 556.

Data Length: 1 byte
 Resolution: 1 %/bit , -125% offset
 Data Range: -125 to 125 %
 Operating Range: -125% to 0 %
 Type: Measured
 Suspect Parameter Number: 520
 Parameter Group Number: [61440]

spn521 - Brake Pedal Position - Ratio of brake pedal position to maximum pedal position. Used for electric brake applications. 0% means no braking. Also when there are two brake pedals on the machine (Left Brake Pedal Position SPN-tba and Right Brake Pedal Position SPN-tba) the maximum of the two should be transmitted for Brake Pedal Position.

Data Length: 1 byte
 Resolution: 0.4 %/bit , 0 offset
 Data Range: 0 to 100 %
 Type: Measured
 Suspect Parameter Number: 521
 Parameter Group Number: [61441]

spn522 - Percent Clutch Slip - Parameter which represents the ratio of input shaft speed to current engine speed (in percent).

Data Length: 1 byte
 Resolution: 0.4 %/bit , 0 offset
 Data Range: 0 to 100 %
 Type: Measured
 Suspect Parameter Number: 522
 Parameter Group Number: [61442]

$$\text{Percent Clutch Slip} = \frac{\text{Engine rpm} - \text{Input shaft rpm}}{\text{Engine rpm}} \times 100 \quad (\text{Eq.1})$$

EQ 522_A

spn523 - Current Gear - The gear currently engaged in the transmission or the last gear engaged while the transmission is in the process of shifting to the new or selected gear. Transitions toward a destination gear will not be indicated. Once the selected gear has been engaged then Current Gear will reflect that gear.

Data Length: 1 byte
 Resolution: 1 gear value/bit , -125 offset
 Data Range: -125 to 125
 Operating Range: -125 to +125, negative values are reverse gears, positive values are forward gears, zero is neutral. 251 (0xFB) is park.
 Type: Measured
 Suspect Parameter Number: 523
 Parameter Group Number: [61445]

spn524 - Selected Gear - The gear that the transmission will attempt to achieve during the current shift if a shift is in progress, or the next shift if one is pending (i.e., waiting for torque reduction to initiate the shift).

Data Length: 1 byte
 Resolution: 1 gear value/bit , -125 offset
 Data Range: -125 to 125
 Operating Range: -125 to +125, negative values are reverse gears, positive values are forward gears, zero is neutral. 251 (0xFB) is park.
 Type: Status
 Suspect Parameter Number: 524
 Parameter Group Number: [61445]

spn525 - Requested Gear - Gear requested by the operator, ABS, or engine. Negative values are reverse gears, positive values are forward gears, zero is neutral, parameter specific indicators are listed below. Parameter specific values for this parameter are as follows:

- 0xFD (253 dec) = Hold current gear
- 0xFC (252 dec) = Forward Drive Position
- 0xFB (251 dec) = `Park' position
- 0xFA (250 dec) = Forward `Low' position
- 0xF9 (249 dec) = Upshift 1 gear from current position
- 0xF8 (248 dec) = Upshift 2 gears from current position
- 0xF7 (247 dec) = Downshift 1 gear from current position
- 0xF6 (246 dec) = Downshift 2 gears from current position
- 0xF5 (245 dec) = D-1: 1st forward selector position referenced from `Drive'
- 0xF4 (244 dec) = D-2: 2nd forward selector position referenced from `Drive'
- 0xF3 (243 dec) = D-3: 3rd forward selector position referenced from `Drive'
- 0xF2 (242 dec) = D-4: 4th forward selector position referenced from `Drive'
- 0xF1 (241 dec) = D-5: 5th forward selector position referenced from `Drive'
- 0xF0 (240 dec) = D-6: 6th forward selector position referenced from `Drive'

0xEF (239 dec) = D-7: 7th forward selector position referenced from `Drive`
 0xEE (238 dec) = Between two shift selector positions (if detail is unknown)
 0xED (237 dec) = Between two reverse shift selector positions
 0xEC (236 dec) = Between two forward shift selector positions
 0xEB (235 dec) = Between D-7 and D-6 shift selector positions
 0xEA (234 dec) = Between D-6 and D-5 shift selector positions
 0xE9 (233 dec) = Between D-5 and D-4 shift selector positions
 0xE8 (232 dec) = Between D-4 and D-3 shift selector positions
 0xE7 (231 dec) = Between D-3 and D-2 shift selector positions
 0xE6 (230 dec) = Between D-2 and D-1 shift selector positions
 0xE5 (229 dec) = Between D-1 and `Drive` shift selector positions
 0xE4 (228 dec) = Between `Drive` and `Neutral` shift selector positions
 0xE3 (227 dec) = Between `Neutral` and `Reverse` shift selector positions
 0xE2 (226 dec) = Between `Reverse` and `Park` shift selector positions
 0xE1 (225 dec) = Press of momentary button to reselect current position
 0xE0 (224 dec) = Position unknown and/or no buttons pressed
 0xDF - 0x41 (223dec - 65dec) = Reserved
 0x3D - 0x00 (61dec - 0dec) = Reserved

Forward selector position from drive (0xF5 to 0xEF) - Indicates shift selector position in reference to the `Drive` position on the selector. It is possible that the shift selector software may not know the number of forward ranges. The shift selector may identify the position selected by the operator while the transmission ECU determines what range or gear that represents. If there is a digital display, the transmission ECU would communicate what is to be displayed via another message such as ETC#2 or ETC#7. For example: Consider a vehicle with a 5-speed automatic transmission with the shift lever on the column. Suppose that shift selector has a limited number of positions, such that having positions for D-4-3-2-1 is not an option. For this example, assume there are only have enough lever positions for D-3-2-1. Pulling the lever into "D" will put the transmission in 5th (highest gear). It is desired that pulling the lever to the physical '3' position will limit the transmission to a maximum range of 3rd gear. When the selector is pulled down into "3", the shifter selector itself has no way of correlating this physical lever position to the desired gear; it would have to be calibrated with software to tell it this information. If not calibrated, the shift selector cannot directly command the transmission to go to 3rd gear; it only knows it's one notch below drive. However, if "D-1" (lever position, as opposed to desired gear) is broadcast by the selector, the transmission ECU can receive this and then make the determination of what range is desired. The benefit is that no specific calibration of the shift selector is required.

Between selector positions (0xEE to 0xE2) - Indicates the shift selector is not in an appropriate position. If a lever-type shift selector with a mechanical display is stuck between detents, it may appear to the operator that it is in the desired position when in fact it is not. The shift selector may be capable of reporting only that it is between positions or that it is between forward or reverse positions. If known, the transmission ECU may respond differently depending on which positions are involved.

Reselect current position (0xE1) - If the TC1 message continues to send the position last selected, then a capability to reselect the same position is required. For example: If a `Neutral` to `Drive` shift is selected and that shift is inhibited (say for high engine speed), it may be necessary for the operator to reselect `Drive` after the inhibit conditions pass in order for the transmission ECU to honor the request.

Position unknown and/or no buttons pressed (0xE0) - A push-button style shift selector with momentary contact buttons may send this indicator after initialization before any buttons are pressed, or before the transmission ECU determines and communicates the initial selection. This indicator could also be sent between button presses as an alternative to sending the last button press.

Data Length:	1 byte
Resolution:	1 gear value/bit , -125 offset
Data Range:	-125 to 125
Operating Range:	-64 to 64
Type:	Status
Suspect Parameter Number:	525
Parameter Group Number:	[256]

spn526 - Actual Gear Ratio - Actual ratio of input shaft speed to output shaft speed.

Data Length:	2 bytes
Resolution:	0.001/bit , 0 offset
Data Range:	0 to 64.255
Type:	Measured
Suspect Parameter Number:	526
Parameter Group Number:	[61445]

spn527 - Cruise Control States - This parameter is used to indicate the current state, or mode, of operation by the cruise

control device. This is a status parameter. (Reference: PGN 65,265)

This parameter is used to indicate the current state, or mode, of operation by the cruise control device. This is a status parameter. (Reference: PGN 65,265)

Bit Length: 3 bits
 Type: Status
 Suspect Parameter Number: 527
 Parameter Group Number: [65265]

Bit States	Cruise Control State
000	Off/Disabled
001	Hold
010	Accelerate
011	Decelerate/Coast
100	Resume
101	Set
110	Accelerator override
111	Not available

State Descriptions:

000b Off/Disabled—Used to indicate that the cruise control device is off or on standby. Note that the cruise control system switch does not necessarily have to be off to be in this mode.

001b Hold —Used to indicate that the cruise control device is active and currently maintaining a captured operating speed.

010b Accelerate—Used to indicate that the cruise control device is in the process of ramping up the operating speed.

011b Decelerate —Used to indicate that the cruise control device is in the process of ramping down, or coasting, the operating speed.

100b Resume—Used to indicate that the cruise control device is in the process of resuming the operating speed to a previously captured value.

101b Set—Used to indicate that the cruise control device is establishing the current vehicle speed as the operating speed (captured value).

110b Accelerator Override —Used to indicate that the cruise control device is active but not currently maintaining the captured operating speed.

TABLE SPN527_A -- CRUISE CONTROL STATES

spn528 - Engine Speed At Point 2 (Engine Configuration) - Engine speed of point 2 of the engine torque map (see PGN 65251 and supporting document). In engine configuration mode 1 and 3, point 2 is defined as the kick-in point from which torque is reduced to zero. In mode 2 (see Table PGN65251_A), there are no special requirements for the definition of this point.

Data Length: 2 bytes
 Resolution: 0.125 rpm/bit , 0 offset
 Data Range: 0 to 8,031.875 rpm
 Type: Measured
 Suspect Parameter Number: 528
 Parameter Group Number: [65251]

spn529 - Engine Speed At Point 3 (Engine Configuration) - Engine speed of point 3, 4, and 5 of the engine torque map (see PGN 65251 and supporting document). It is recommended that one of these points indicate the peak torque point for the current engine torque map. Points 3, 4, and 5 are optional and lie between idle and point 2.

Data Length:	2 bytes
Resolution:	0.125 rpm/bit , 0 offset
Data Range:	0 to 8,031.875 rpm
Type:	Measured
Suspect Parameter Number:	529
Parameter Group Number:	[65251]

spn530 - Engine Speed At Point 4 (Engine Configuration) - Engine speed of point 3, 4, and 5 of the engine torque map (see PGN 65251 and supporting document). It is recommended that one of these points indicate the peak torque point for the current engine torque map. Points 3, 4, and 5 are optional and lie between idle and point 2.

Data Length:	2 bytes
Resolution:	0.125 rpm/bit , 0 offset
Data Range:	0 to 8,031.875 rpm
Type:	Measured
Suspect Parameter Number:	530
Parameter Group Number:	[65251]

spn531 - Engine Speed At Point 5 (Engine Configuration) - Engine speed of point 3, 4, and 5 of the engine torque map (see PGN 65251 and supporting document). It is recommended that one of these points indicate the peak torque point for the current engine torque map. Points 3, 4, and 5 are optional and lie between idle and point 2.

Data Length:	2 bytes
Resolution:	0.125 rpm/bit , 0 offset
Data Range:	0 to 8,031.875 rpm
Type:	Measured
Suspect Parameter Number:	531
Parameter Group Number:	[65251]

spn532 - Engine Speed At High Idle, Point 6 (Engine Configuration) - Engine speed of high idle (point 6) of the engine torque map (see PGN 65251 and supporting document). In engine configuration mode 3 (see Table SPN976_A), point 6 is not defined by the engine torque map but by the governor characteristic and the zero torque line.

Data Length:	2 bytes
Resolution:	0.125 rpm/bit , 0 offset
Data Range:	0 to 8,031.875 rpm
Type:	Measured
Suspect Parameter Number:	532
Parameter Group Number:	[65251]

spn533 - Maximum Momentary Engine Override Speed, Point 7 (Engine Configuration) - The maximum engine speed above high idle allowed by the engine control during a momentary high idle override. This duration of the override is limited by the maximum momentary override time limit, SPN 534.

Data Length:	2 bytes
Resolution:	0.125 rpm/bit , 0 offset
Data Range:	0 to 8,031.875 rpm
Type:	Measured

Suspect Parameter Number: 533
 Parameter Group Number: [65251]

spn534 - Maximum Momentary Override Time Limit (Engine Configuration) - The maximum time limit allowed to override the engine's high idle speed.

Data Length: 1 byte
 Resolution: 0.1 s/bit , 0 offset
 Data Range: 0 to 25 s
 Operating Range: 0 to 25 sec, 0 = no override of high idle allowed, 255 = not applicable (no time restriction)
 Type: Measured
 Suspect Parameter Number: 534
 Parameter Group Number: [65251]

spn535 - Requested Speed Control Range Lower Limit (Engine Configuration) - The minimum engine speed that the engine will allow when operating in a speed control/limit mode.

Data Length: 1 byte
 Resolution: 10 rpm/bit , 0 offset
 Data Range: 0 to 2,500 rpm
 Type: Measured
 Suspect Parameter Number: 535
 Parameter Group Number: [65251]

spn536 - Requested Speed Control Range Upper Limit (Engine Configuration) - The maximum engine speed regardless of load that the engine will allow when operating in a speed control/limit mode, excluding any maximum momentary engine override speed, if supported.

Data Length: 1 byte
 Resolution: 10 rpm/bit , 0 offset
 Data Range: 0 to 2,500 rpm
 Type: Measured
 Suspect Parameter Number: 536
 Parameter Group Number: [65251]

spn537 - Requested Torque Control Range Lower Limit (Engine Configuration) - The minimum engine torque that the engine will allow when operating in a torque control/limit mode.

Data Length: 1 byte
 Resolution: 1 %/bit , -125% offset
 Data Range: -125 to 125 %
 Operating Range: 0 to 125%
 Type: Measured
 Suspect Parameter Number: 537
 Parameter Group Number: [65251]

spn538 - Requested Torque Control Range Upper Limit (Engine Configuration) - The maximum engine torque that the engine will allow when operating in a torque control/limit mode.

Data Length:	1 byte
Resolution:	1 %/bit , -125% offset
Data Range:	-125 to 125 %
Operating Range:	0 to 125%
Type:	Measured
Suspect Parameter Number:	538
Parameter Group Number:	[65251]

spn539 - Percent Torque At Idle, Point 1 (Engine Configuration) - The torque limit that indicates the available engine torque which can be provided by the engine at idle speed. This parameter may be influenced by engine temperature (after power up) and other stationary changes (calibration offsets, sensor failures, etc.) See also SPN 188. The data is transmitted in indicated torque as a percent of the reference engine torque.

Data Length:	1 byte
Resolution:	1 %/bit , -125% offset
Data Range:	-125 to 125 %
Operating Range:	0 to 125%
Type:	Measured
Suspect Parameter Number:	539
Parameter Group Number:	[65251]

spn540 - Percent Torque At Point 2 (Engine Configuration) - The torque limit that indicates the available engine torque which can be provided by the engine at point 2 of the engine map (see PGN 65251 and supporting documents). In engine configuration mode 1 and 3 (see Table PGN65251_A see PGN 65251), point 2 is defined as the kick-in point from which torque is reduced to zero. In mode 2, there are no special requirements for the definition of this point. The data is transmitted in indicated torque as a percent of the reference engine torque.

Data Length:	1 byte
Resolution:	1 %/bit , -125% offset
Data Range:	-125 to 125 %
Operating Range:	0 to 125%
Type:	Measured
Suspect Parameter Number:	540
Parameter Group Number:	[65251]

spn541 - Percent Torque At Point 3 (Engine Configuration) - The torque limit that indicates the available engine torque which can be provided by the engine at point 3, 4, and 5 of the engine map (see PGN 65251 and supporting documents).. It is required that one of these points indicate the peak torque point for the current engine torque map. Points 3, 4, and 5 lie between idle and point 2. The data is transmitted in indicated torque as a percent of the reference engine torque.

Data Length:	1 byte
Resolution:	1 %/bit , -125% offset
Data Range:	-125 to 125 %
Operating Range:	0 to 125%
Type:	Measured
Suspect Parameter Number:	541
Parameter Group Number:	[65251]

spn542 - Percent Torque At Point 4 (Engine Configuration) - The torque limit that indicates the available engine torque which can be provided by the engine at point 3, 4, and 5 of the engine map (see PGN 65251 and supporting documents). It is required that one of these points indicate the peak torque point for the current engine torque map. Points 3, 4, and 5 lie between idle and point 2. The data is transmitted in indicated torque as a percent of the reference engine torque.

Data Length:	1 byte
Resolution:	1 %/bit , -125% offset
Data Range:	-125 to 125 %
Operating Range:	0 to 125%
Type:	Measured
Suspect Parameter Number:	542
Parameter Group Number:	[65251]

spn543 - Percent Torque At Point 5 (Engine Configuration) - The torque limit that indicates the available engine torque which can be provided by the engine at point 3, 4, and 5 of the engine map (see PGN 65251 and supporting documents). It is required that one of these points indicate the peak torque point for the current engine torque map. Points 3, 4, and 5 lie between idle and point 2. The data is transmitted in indicated torque as a percent of the reference engine torque.

Data Length:	1 byte
Resolution:	1 %/bit , -125% offset
Data Range:	-125 to 125 %
Operating Range:	0 to 125%
Type:	Measured
Suspect Parameter Number:	543
Parameter Group Number:	[65251]

spn544 - Reference Engine Torque (Engine Configuration) - This parameter is the 100% reference value for all defined indicated engine torque parameters. It is only defined once and doesn't change if a different engine torque map becomes valid.

Data Length:	2 bytes
Resolution:	1 Nm/bit , 0 offset
Data Range:	0 to 64,255 Nm
Type:	Measured
Suspect Parameter Number:	544
Parameter Group Number:	[65251]

spn545 - Gain (Kp) Of The Endspped Governor (Engine Configuration) - The endspped governor is defined as a linear line with the following equations (Capital letters mean physical values, small letters mean normalized values). Refer to Figures PGN65251_A and PGN65251_B. The gain KP/kp is defined as a positive value. The factor 4096 is necessary for realizing flat curves with sufficient resolution as well as very steep curves. $KP = \text{delta Torque} / \text{delta Speed kp (normalized)} = KP * 250/100\% * 8031 \text{ rpm}/64255 * 4096 = KP * 1280 \text{ rpm}/\%$

Data Length:	2 bytes
Resolution:	1/1280 %/rpm per bit , 0 offset
Data Range:	0 to 50.2 %/rpm
Type:	Measured
Suspect Parameter Number:	545
Parameter Group Number:	[65251]

spn546 - Retarder Speed At Idle, Point 1 (Retarder Configuration) - Please reference PGN 65249

Data Length: 2 bytes
 Resolution: 0.125 rpm/bit , 0 offset
 Data Range: 0 to 8,031.875 rpm
 Type: Measured
 Suspect Parameter Number: 546
 Parameter Group Number: [65249]

spn547 - Retarder Speed At Peak Torque, Point 5 (Retarder Configuration) - Please reference PGN 65249

Data Length: 2 bytes
 Resolution: 0.125 rpm/bit , 0 offset
 Data Range: 0 to 8,031.875 rpm
 Type: Measured
 Suspect Parameter Number: 547
 Parameter Group Number: [65249]

spn548 - Maximum Retarder Speed, Point 2 (Retarder Configuration) - Maximum speed of retarder (Please reference PGN 65249).

Data Length: 2 bytes
 Resolution: 0.125 rpm/bit , 0 offset
 Data Range: 0 to 8,031.875 rpm
 Type: Measured
 Suspect Parameter Number: 548
 Parameter Group Number: [65249]

spn549 - Retarder Speed At Point 3 (Retarder Configuration) - Retarder speed of point 3 of the engine retarder torque map. Please reference PGN 65249.

Data Length: 2 bytes
 Resolution: 0.125 rpm/bit , 0 offset
 Data Range: 0 to 8,031.875 rpm
 Type: Measured
 Suspect Parameter Number: 549
 Parameter Group Number: [65249]

spn550 - Retarder Speed At Point 4 (Retarder Configuration) - Retarder speed of point 4 of the engine retarder torque map. Please reference PGN 65249.

Data Length: 2 bytes
 Resolution: 0.125 rpm/bit , 0 offset
 Data Range: 0 to 8,031.875 rpm
 Type: Measured
 Suspect Parameter Number: 550
 Parameter Group Number: [65249]

spn551 - Percent Torque At Idle, Point 1 (Retarder Configuration) - The torque limit that indicates the

available retarder torque which can be provided by the retarder at idle speed. The data is transmitted in indicated torque as a percent of the reference retarder torque.

Data Length:	1 byte
Resolution:	1 %/bit , -125% offset
Data Range:	-125 to 125 %
Operating Range:	-125 to 0%
Type:	Measured
Suspect Parameter Number:	551
Parameter Group Number:	[65249]

spn552 - Percent Torque At Maximum Speed, Point 2 (Retarder Configuration) - The torque limit that indicates the available retarder torque which can be provided by the retarder at its maximum speed. Please reference PGN 65249. The data is transmitted in indicated torque as a percent of the reference retarder torque.

Data Length:	1 byte
Resolution:	1 %/bit , -125% offset
Data Range:	-125 to 125 %
Operating Range:	-125 to 0%
Type:	Measured
Suspect Parameter Number:	552
Parameter Group Number:	[65249]

spn553 - Percent Torque At Point 3 (Retarder Configuration) - The torque limit that indicates the available retarder torque which can be provided by the retarder at points 3 and 4 of the retarder torque map. Please reference PGN 65249. The data is transmitted in indicated torque as a percent of the reference retarder torque.

Data Length:	1 byte
Resolution:	1 %/bit , -125% offset
Data Range:	-125 to 125 %
Operating Range:	-125 to 0%
Type:	Measured
Suspect Parameter Number:	553
Parameter Group Number:	[65249]

spn554 - Percent Torque At Point 4 (Retarder Configuration) - The torque limit that indicates the available retarder torque which can be provided by the retarder at points 3 and 4 of the retarder torque map. Please reference PGN 65249. The data is transmitted in indicated torque as a percent of the reference retarder torque.

Data Length:	1 byte
Resolution:	1 %/bit , -125% offset
Data Range:	-125 to 125 %
Operating Range:	-125 to 0%
Type:	Measured
Suspect Parameter Number:	554
Parameter Group Number:	[65249]

spn555 - Percent Torque At Peak Torque, Point 5 (Retarder Configuration) - The torque limit that

indicates the available retarder torque which can be provided by the retarder at point 5 of the retarder torque map. Please reference PGN 65249. The data is transmitted in indicated torque as a percent of the reference retarder torque.

Data Length:	1 byte
Resolution:	1 %/bit , -125% offset
Data Range:	-125 to 125 %
Operating Range:	-125 to 0%
Type:	Measured
Suspect Parameter Number:	555
Parameter Group Number:	[65249]

spn556 - Reference Retarder Torque (Retarder Configuration) - This parameter is the 100% reference value for all defined indicated retarder torque parameters. It is only defined once and doesn't change if a different retarder torque map becomes valid.

Data Length:	2 bytes
Resolution:	1 Nm/bit , 0 offset
Data Range:	0 to 64,255 Nm
Type:	Measured
Suspect Parameter Number:	556
Parameter Group Number:	[65249]

spn557 - Retarder Control Method (Retarder Configuration) - This parameter identifies the number of steps used by the retarder.

Data Length:	1 byte
Resolution:	1 step/bit , 0 offset
Data Range:	0 to 250 steps
Operating Range:	0: continuous control, 1 On/Off control, 2 to 250: Number of steps
Type:	Measured
Suspect Parameter Number:	557
Parameter Group Number:	[65249]

spn558 - Accelerator Pedal 1 Low Idle Switch - Switch signal which indicates the state of the accelerator pedal 1 low idle switch. The low idle switch is defined in SAE J1843.

00 Accelerator pedal 1 not in low idle condition
 01 Accelerator pedal 1 in low idle condition
 10 Error
 11 Not available

Bit Length:	2 bits
Type:	Measured
Suspect Parameter Number:	558
Parameter Group Number:	[61443]

spn559 - Accelerator Pedal Kickdown Switch - Switch signal which indicates whether the accelerator pedal kickdown switch is opened or closed. The kickdown switch is defined in SAE J1843.

00 Kickdown passive
 01 Kickdown active

Bit Length:	2 bits
Type:	Measured

Suspect Parameter Number: 559
 Parameter Group Number: [61443]

spn560 - Driveline Engaged - Driveline engaged indicates the transmission controlled portion of the driveline is engaged sufficiently to allow a transfer of torque through the transmission. Driveline engaged is ACTIVE whenever the transmission is in gear and the clutch (if controlled by the transmission controller) is less than 100% clutch slip (clutch able to transfer torque). This parameter should be used in conjunction with the parameter 'shift in Process' (SPN 574). While a shift is in process, the receiver should not assume that the driveline is either fully engaged or disengaged (i.e., cruise control).

00 Driveline disengaged
 01 Driveline engaged

Bit Length: 2 bits
 Type: Measured
 Suspect Parameter Number: 560
 Parameter Group Number: [61442]

spn561 - ASR Engine Control Active - State signal which indicates that ASR engine control has been commanded to be active. Active means that ASR actually tries to control the engine. This state signal is independent of other control commands to the engine (e.g., from the transmission) which may have higher priority.

00 - ASR engine control passive but installed
 01 - ASR engine control active

Bit Length: 2 bits
 Type: Status
 Suspect Parameter Number: 561
 Parameter Group Number: [61441]

spn562 - ASR Brake Control Active - State signal which indicates that ASR brake control is active. Active means that ASR actually controls wheel brake pressure at one or more wheels of the driven axle(s).

00 - ASR brake control passive but installed
 01 - ASR brake control active

Bit Length: 2 bits
 Type: Status
 Suspect Parameter Number: 562
 Parameter Group Number: [61441]

spn563 - Anti-Lock Braking (ABS) Active - State signal which indicates that the ABS is active. The signal is set active when wheel brake pressure actually starts to be modulated by ABS and is reset to passive when all wheels are in a stable condition for a certain time. The signal can also be set active when driven wheels are in high slip (e.g., caused by retarder). Whenever the ABS system is not fully operational (due to a defect or during off-road ABS operation), this signal is only valid for that part of the system that is still working. When ABS is switched off completely, the flag is set to passive regardless of the current wheel slip conditions.

00 ABS passive but installed
 01 ABS active

Bit Length: 2 bits
 Type: Status
 Suspect Parameter Number: 563
 Parameter Group Number: [61441]

spn564 - Differential Lock State - Central - State used which indicates the condition of the central differential lock. The

differential locks are located as defined in attached figure SPN564_A.

- 00 Differential lock disengaged
- 01 Differential lock engaged

Bit Length: 2 bits
 Type: Status
 Suspect Parameter Number: 564
 Parameter Group Number: [61446]

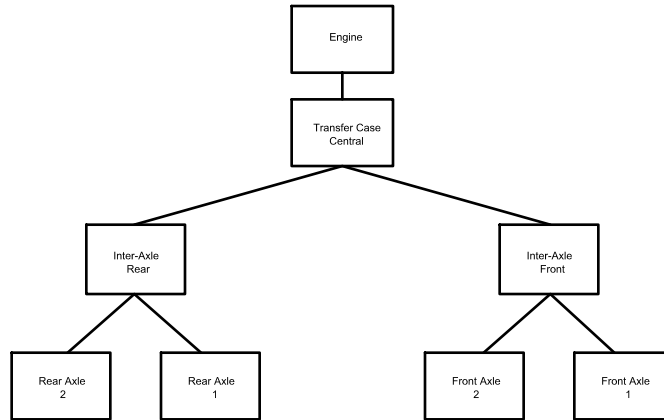

FIGURE SPN564_A -- DIFFERENTIAL LOCK POSITIONS

spn565 - Differential Lock State - Central Front - State used which indicates the condition of the central front differential lock. The differential locks are located as defined in figure SPN564_A.

- 00 Differential lock disengaged
- 01 Differential lock engaged

Bit Length: 2 bits
 Type: Status
 Suspect Parameter Number: 565
 Parameter Group Number: [61446]

spn566 - Differential Lock State - Central Rear - State used which indicates the condition of the central rear differential lock. The differential locks are located as defined in figure SPN564_A.

- 00 Differential lock disengaged
- 01 Differential lock engaged

Bit Length: 2 bits
 Type: Status
 Suspect Parameter Number: 566
 Parameter Group Number: [61446]

spn567 - Differential Lock State - Front Axle 1 - State used which indicates the condition of the front axle 1 differential lock. The differential locks are located as defined in figure SPN564_A.

- 00 Differential lock disengaged
- 01 Differential lock engaged

Bit Length: 2 bits
 Type: Status
 Suspect Parameter Number: 567
 Parameter Group Number: [61446]

spn568 - Differential Lock State - Front Axle 2 - State used which indicates the condition of the front axle 2 differential lock. The differential locks are located as defined in figure SPN 564_A.

00 Differential lock disengaged
01 Differential lock engaged

Bit Length: 2 bits
Type: Status
Suspect Parameter Number: 568
Parameter Group Number: [61446]

spn569 - Differential Lock State - Rear Axle 1 - State used which indicates the condition of the rear axle 1 differential lock. The differential locks are located as defined in figure SPN 564_A.

00 Differential lock disengaged
01 Differential lock engaged

Bit Length: 2 bits
Type: Status
Suspect Parameter Number: 569
Parameter Group Number: [61446]

spn570 - Differential Lock State - Rear Axle 2 - State used which indicates the condition of the rear axle 2 differential lock. The differential locks are located as defined in figure SPN 564_A.

00 Differential lock disengaged
01 Differential lock engaged

Bit Length: 2 bits
Type: Status
Suspect Parameter Number: 570
Parameter Group Number: [61446]

spn571 - Retarder Enable - Brake Assist Switch - Switch signal which indicates whether the operator wishes the retarder to be enabled for vehicle braking assist. The retarder does not check this switch, nor does the enabling of this switch engage the retarder. When this switch is 'enabled,' the devices constructing TSC1 ' destination retarder messages may command retarder torque for braking. For example, the cruise control should not request retarder torque if this switch is not 'enabled.' The switch exists to prevent the engine retarder from being asked to be engaged via TSC1 in a noise sensitive area. See also SPN 572

00 Retarder - brake assist disabled
01 Retarder - brake assist enabled

Bit Length: 2 bits
Type: Measured
Suspect Parameter Number: 571
Parameter Group Number: [61440]

spn572 - Retarder Enable - Shift Assist Switch - Switch signal which indicates whether the operator wishes the retarder to be enabled for transmission shift assist. The retarder does not check this switch, nor does the enabling of this switch engage the retarder. When this switch is 'enabled,' the transmission may activate the retarder (via the TSC1 message) to increase the rate of engine deceleration to assist in shift control. The switch exists to prevent the engine retarder from being asked to be engaged via TSC1 in a noise sensitive area. See SPN 571.

00 Retarder - shift assist disabled
01 Retarder - shift assist enabled

Bit Length: 2 bits
Type: Measured

Suspect Parameter Number: 572
 Parameter Group Number: [61440]

spn573 - Torque Converter Lockup Engaged - State signal which indicates whether the torque converter lockup is engaged.

- 00 Torque converter lockup disengaged
- 01 Torque converter lockup engaged

Bit Length: 2 bits
 Type: Status
 Suspect Parameter Number: 573
 Parameter Group Number: [61442]

spn574 - Shift In Process - Indicates that the transmission is in process of shifting from the current gear to the selected gear. This state is generally ACTIVE during the entire time that the transmission controls the vehicle. This includes any transmission clutch control, all engine control sequences, pulling to transmission neutral, and engaging the destination gear (e.g., until it is no longer sending commands and/or limits to the engine). See also SPN 560. (See Figure SPN574_A)

- 00 - Shift is not in process
- 01 - Shift in process

Bit Length: 2 bits
 Type: Measured
 Suspect Parameter Number: 574
 Parameter Group Number: [61442]

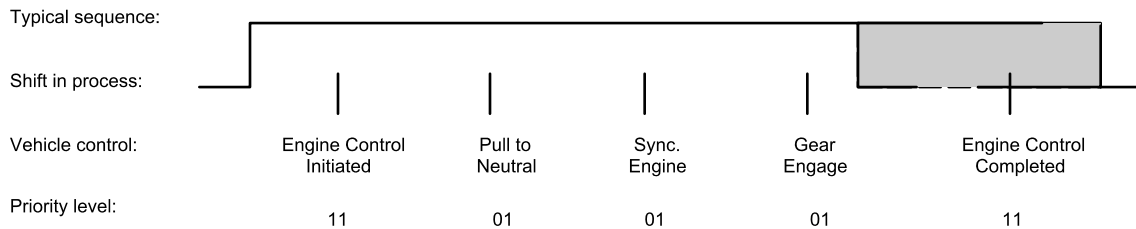

FIGURE SPN574_A -- SHIFT IN PROCESS

spn575 - ABS Off-road Switch - Switch signal which indicates the position of the ABS off-road switch.

- 00 - ABS off-road switch passive
- 01 - ABS off-road switch active

Bit Length: 2 bits
 Type: Measured
 Suspect Parameter Number: 575
 Parameter Group Number: [61441]

spn576 - ASR Off-road Switch - Switch signal which indicates the position of the ASR off-road switch.

- 00 - ASR off-road switch passive
- 01 - ASR off-road switch active

Bit Length: 2 bits
 Type: Measured
 Suspect Parameter Number: 576
 Parameter Group Number: [61441]

spn577 - ASR "Hill Holder" Switch - Switch signal which indicates the position of the ASR 'hill holder' switch.

- 00 - ASR 'hill holder' switch passive
- 01 - ASR 'hill holder' switch active

Bit Length: 2 bits
 Type: Measured
 Suspect Parameter Number: 577
 Parameter Group Number: [61441]

spn578 - Drive Axle Temperature - Temperature of axle lubricant in drive axle.

Data Length: 1 byte
 Resolution: 1 deg C/bit , -40 deg C offset
 Data Range: -40 to 210 deg C
 Type: Measured
 Suspect Parameter Number: 578
 Parameter Group Number: [65273]

spn579 - Drive Axle Lift Air Pressure - Gage pressure of air in system that utilizes compressed air to provide force between axle and frame.

Data Length: 1 byte
 Resolution: 4 kPa/bit , 0 offset
 Data Range: 0 to 1000 kPa
 Type: Measured
 Suspect Parameter Number: 579
 Parameter Group Number: [65273]

spn580 - Altitude - Altitude of the vehicle referenced to sea level at standard atmospheric pressure and temperature.

Data Length: 2 bytes
 Resolution: 0.125 m/bit , -2500 m offset
 Data Range: -2500 to 5531.875 m
 Type: Measured
 Suspect Parameter Number: 580
 Parameter Group Number: [65256]

spn581 - Transmission Gear Ratio - The transmission configuration describes the number of forward gears, the number of reverse gears, and the ratio of each gear with the following resolution.

Data Length: 2 bytes
 Resolution: 0.001/bit , 0 offset
 Data Range: 0 to 64.255
 Type: Measured
 Suspect Parameter Number: 581
 Parameter Group Number: [65250]

spn582 - Axle Weight - Total mass imposed by the tires on the road surface at the specified axle.

Data Length: 2 bytes

Resolution: 0.5 kg/bit , 0 offset
 Data Range: 0 to 32,127.5 kg
 Type: Measured
 Suspect Parameter Number: 582
 Parameter Group Number: [65258]

spn583 - Pitch - Pitch of the vehicle as calculated by the navigation device(s).

Data Length: 2 bytes
 Resolution: 1/128 deg/bit , -200 deg offset
 Data Range: -200 to 301.99 deg
 Operating Range: -200 deg (DECENT) to +301.992 deg (ASCENT)
 Type: Measured
 Suspect Parameter Number: 583
 Parameter Group Number: [65256]

spn584 - Latitude - Latitude position of the vehicle.

Data Length: 4 bytes
 Resolution: 10⁻⁷ deg/bit , -210 deg offset
 Data Range: -210 to 211.1008122 deg
 Operating Range: -210 deg (SOUTH) to +211.108122 deg (NORTH)
 Type: Measured
 Suspect Parameter Number: 584
 Parameter Group Number: [65267]

spn585 - Longitude - Longitude position of the vehicle.

Data Length: 4 bytes
 Resolution: 10⁻⁷ deg/bit , -210 deg offset
 Data Range: -210 to 211.1008122 deg
 Operating Range: -210 deg (WEST) to +211.108122 deg (EAST)
 Type: Measured
 Suspect Parameter Number: 585
 Parameter Group Number: [65267]

spn586 - Make - Make of the component corresponding to the codes defined in the American Trucking Association Vehicle Maintenance Reporting Standard (ATA/VMRS). It is suggested that spaces (ASCII 32) are used to fill the remaining characters if the ATA/VMRS make code is less than five characters in length. NOTE- The ASCII character "*" is reserved as a delimiter.

Data Length: 5 bytes
 Resolution: ASCII , 0 offset
 Data Range: 0 to 255 per byte
 Type: Measured
 Suspect Parameter Number: 586
 Parameter Group Number: [65259]

spn587 - Model - Model of the component. NOTE - The ASCII character "*" is reserved as a delimiter.

Data Length: Variable - up to 200 characters ("*" delimited)
 Resolution: ASCII , 0 offset
 Data Range: 0 to 255 per byte
 Type: Measured
 Suspect Parameter Number: 587
 Parameter Group Number: [65259]

spn588 - Serial Number - Serial number of the component. NOTE - The ASCII character "*" is reserved as a delimiter.

Data Length: Variable - up to 200 characters ("*" delimited)
 Resolution: ASCII , 0 offset
 Data Range: 0 to 255 per byte
 Type: Measured
 Suspect Parameter Number: 588
 Parameter Group Number: [65259]

spn589 - Alternator Speed - Actual rotation speed of the alternator.

Data Length: 2 bytes
 Resolution: 0.5 rpm/bit , 0 offset
 Data Range: 0 to 32,127.5 rpm
 Type: Measured
 Suspect Parameter Number: 589
 Parameter Group Number: [65237]

spn590 - Idle Shutdown Timer State - Status signal which indicates the current mode of operation of the idle shutdown timer system. See Figure SPN590_A.

- 00 - Inactive
- 01 - Active

Bit Length: 2 bits
 Type: Status
 Suspect Parameter Number: 590
 Parameter Group Number: [65252]

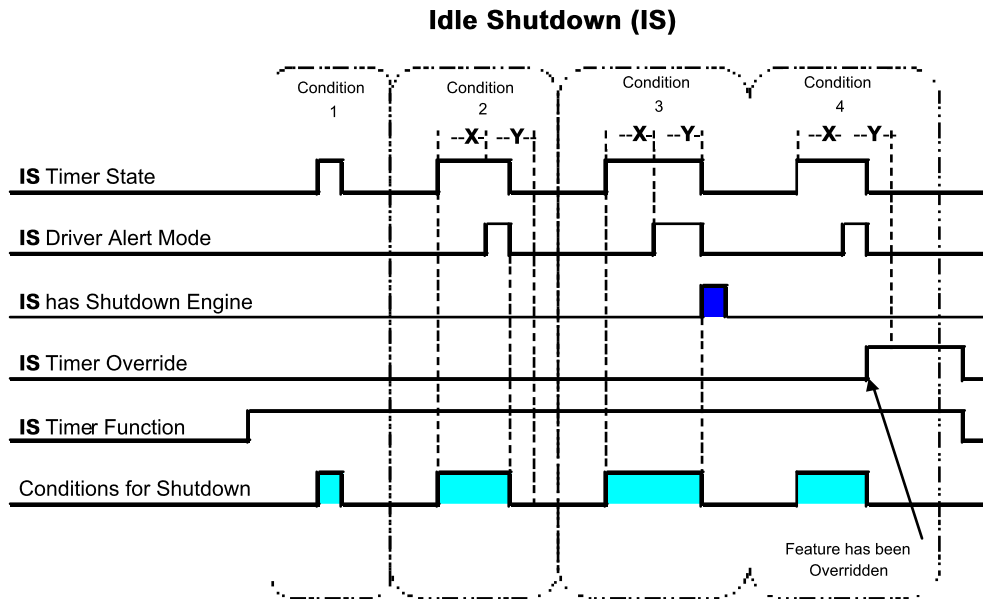

Condition 1- When the IS Timer Override is inactive, the IS Timer State will become inactive if the conditions for shutdown no longer exist before the “X” time interval has expired or IS Driver Alert Mode is activated.

Condition 2- When the IS Timer Override is inactive, the IS Timer State will become inactive if the conditions for shutdown no longer exist before the IS Driver Alert Mode “Y” time interval has expired.

Condition 3- When the IS Timer Override is inactive, then the IS has Shutdown Engine will be active after the “Y” time interval has expired.

Condition 4 - When the IS Timer Override is active during the “Y” time interval, then the IS feature shall be overridden and will no longer be available until the system has been re-initiated.

NOTE — 0 State— Inactive, disabled in calibration, or conditions for idle shutdown do not exist.
1 State— Active, enabled in calibration, or conditions for idle shutdown do exist.

FIGURE 590_A - IDLE SHUTDOWN (IS)

spn591 - Idle Shutdown Timer Function - Parameter which indicates the configuration of the idle shutdown timer system.

- 00 - Disabled in calibration
- 01 - Enabled in calibration

Bit Length: 2 bits
Type: Measured
Suspect Parameter Number: 591
Parameter Group Number: [65252]

spn592 - Idle Shutdown Timer Override - Status signal which indicates the status of the override feature of the idle shutdown timer system. See Figure SPN590_A.

- 00 - Inactive
- 01 - Active

Bit Length: 2 bits
Type: Status
Suspect Parameter Number: 592
Parameter Group Number: [65252]

spn593 - Idle Shutdown has Shutdown Engine - Status signal which identifies whether or not the engine has been shutdown by the idle shutdown timer system. See Figure SPN590_A.

00 - No
01 - Yes

Bit Length: 2 bits
Type: Status
Suspect Parameter Number: 593
Parameter Group Number: [65252]

spn594 - Idle Shutdown Driver Alert Mode - Status signal which indicates the status of the driver alert mode of the idle shutdown timer system. While the driver alert mode is active, the idle shutdown timer may be overridden. See Figure SPN590_A.

00 - Inactive
01 - Active

Bit Length: 2 bits
Type: Status
Suspect Parameter Number: 594
Parameter Group Number: [65252]

spn595 - Cruise Control Active - Cruise control is switched on. It is not ensured that the engine is controlled by cruise control, as in the case of a large driver's demand the engine is controlled by the driver while cruise control is active (maximum selection of cruise control and driver's demand). The cruise control is set to 0 if a switch off condition occurs.

00 - Cruise control switched off
01 - Cruise control switched on

Bit Length: 2 bits
Type: Measured
Suspect Parameter Number: 595
Parameter Group Number: [65265]

spn596 - Cruise Control Enable Switch - Switch signal which indicates that it is possible to manage the cruise control function.

00 - Cruise control disabled
01 - Cruise control enabled

Bit Length: 2 bits
Type: Measured
Suspect Parameter Number: 596
Parameter Group Number: [65265]

spn597 - Brake Switch - Switch signal which indicates that the driver operated brake foot pedal is being pressed. This brake foot pedal is controlling the vehicles' service brake (total vehicle braking application, not park brakes). It is necessary for safe drivetrain behavior that the switch activates before the physical braking components are activated (i.e. Disengage the cruise control function prior to the activation of friction brakes).

00 - Brake pedal released
01 - Brake pedal depressed
10 - Error
11 - Not Available

Bit Length: 2 bits
Type: Measured
Suspect Parameter Number: 597

Parameter Group Number: [65265]

spn598 - Clutch Switch - Switch signal which indicates that the clutch pedal is being pressed. It is necessary for a safe drivetrain behavior that the clutch switch is set before the clutch is opened (cruise control function).

- 00 - Clutch pedal released
- 01 - Clutch pedal depressed

Bit Length: 2 bits
 Type: Measured
 Suspect Parameter Number: 598
 Parameter Group Number: [65265]

spn599 - Cruise Control Set Switch - Switch signal of the cruise control activator which indicates that the activator is in the position 'set.'

- 00 - Cruise control activator not in the position 'set'
- 01 - Cruise control activator in position 'set'

Bit Length: 2 bits
 Type: Measured
 Suspect Parameter Number: 599
 Parameter Group Number: [65265]

spn600 - Cruise Control Coast (Decelerate) Switch - Switch signal of the cruise control activator which indicates that the activator is in the position 'coast (decelerate).'

- 00 - Cruise control activator not in the position 'coast'
- 01 - Cruise control activator in position 'coast'

Bit Length: 2 bits
 Type: Measured
 Suspect Parameter Number: 600
 Parameter Group Number: [65265]

spn601 - Cruise Control Resume Switch - Switch signal of the cruise control activator which indicates that the activator is in the position 'resume.'

- 00 - Cruise control activator not in the position 'resume'
- 01 - Cruise control activator in position 'resume'

Bit Length: 2 bits
 Type: Measured
 Suspect Parameter Number: 601
 Parameter Group Number: [65265]

spn602 - Cruise Control Accelerate Switch - Switch signal of the cruise control activator which indicates that the activator is in the position 'accelerate.'

- 00 - Cruise control activator not in the position 'accelerate'
- 01 - Cruise control activator in position 'accelerate'

Bit Length: 2 bits
 Type: Measured
 Suspect Parameter Number: 602
 Parameter Group Number: [65265]

spn604 - Transmission Neutral Switch - Identifies the status of the switch that indicates neutral.

00 - Off
01 - On

Bit Length: 2 bits
Type: Status
Suspect Parameter Number: 604
Parameter Group Number: [65219]

spn605 - Refrigerant High Pressure Switch - Switch signal which indicates the position of the high pressure switch in the coolant circuit of an air conditioning system. When the switch is enabled, the pressure inside the circuit is too high and the compressor clutch may be disengaged.

00 - Pressure normal
01 - Pressure too high, compressor clutch may be disengaged

Bit Length: 2 bits
Type: Measured
Suspect Parameter Number: 605
Parameter Group Number: [65252]

spn606 - Momentary Engine Overspeed Enable - Command signal used to indicate that the engine speed may be boosted up to the maximum engine overspeed value to accommodate transmission downshifts. The maximum time for overspeed is limited by the time defined in the engine configuration message (see PGN 65,251). The transmission module must command a 'override disabled' state at least once before the engine will accept a subsequent request for overspeed.

00 Momentary engine overspeed is disabled
01 Momentary engine overspeed is enabled
11 Take no action

Bit Length: 2 bits
Type: Status
Suspect Parameter Number: 606
Parameter Group Number: [61442]

spn607 - Progressive Shift Disable - Command signal used to indicate that progressive shifting by the engine should be disallowed.

00 Progressive shift is not disabled
01 Progressive shift is disabled
11 Take no action

Bit Length: 2 bits
Type: Status
Suspect Parameter Number: 607
Parameter Group Number: [61442]

spn619 - Parking Brake Actuator - Signal which indicates the current state of the actuator(s) that control the parking brake (see also SPN 70).

00 - Parking brake actuator inactive
01 - Parking brake actuator active

Bit Length: 2 bits
Type: Measured
Suspect Parameter Number: 619
Parameter Group Number: [65274]

spn681 - Gear Shift Inhibit Request - Command signal to inhibit gear shifts.

- 00 Gear shifts are allowed (disable function)
- 01 Gear shifts are inhibited (enable function)
- 11 Take no action (leave function as is)

Bit Length: 2 bits
 Type: Status
 Suspect Parameter Number: 681
 Parameter Group Number: [256]

spn682 - Torque Converter Lockup Disable Request - Command signal to prevent torque converter lockup, which may cause problems in certain circumstances for ASR.

- 00 Allow torque convertor lockup
- 01 Disable torque convertor lockup
- 11 Take no action

Bit Length: 2 bits
 Type: Status
 Suspect Parameter Number: 682
 Parameter Group Number: [256]

spn683 - Disengage Driveline Request - Command signal used to simply disengage the driveline, e.g., to prevent engine drag torque from causing high wheel slip on slippery surfaces.

- 00 Allow driveline engagement
- 01 Disengage driveline
- 11 Take no action

Bit Length: 2 bits
 Type: Status
 Suspect Parameter Number: 683
 Parameter Group Number: [256]

spn684 - Requested Percent Clutch Slip - Parameter which represents the percent clutch slip requested by a device.

Data Length: 1 byte
 Resolution: 0.4 %/bit , 0 offset
 Data Range: 0 to 100 %
 Type: Status
 Suspect Parameter Number: 684
 Parameter Group Number: [256]

spn685 - Disengage Differential Lock Request - Front Axle 1 - Command signal used to disengage the various differential locks, e.g., to allow an undistributed individual wheel control by ABS. The differential locks are located as defined in Figure SPN564_A.

- 00 Engage differential lock
- 01 Disengage differential lock
- 11 Take no action

Bit Length: 2 bits
 Type: Status
 Suspect Parameter Number: 685
 Parameter Group Number: [256]

spn686 - Disengage Differential Lock Request - Front Axle 2 - Command signal used to disengage the various differential locks, e.g., to allow an undistributed individual wheel control by ABS. The differential locks are located as defined in Figure SPN564_A.

00 Engage differential lock
01 Disengage differential lock
11 Take no action

Bit Length: 2 bits
Type: Status
Suspect Parameter Number: 686
Parameter Group Number: [256]

spn687 - Disengage Differential Lock Request - Rear Axle 1 - Command signal used to disengage the various differential locks, e.g., to allow an undistributed individual wheel control by ABS. The differential locks are located as defined in Figure SPN564_A.

00 Engage differential lock
01 Disengage differential lock
11 Take no action

Bit Length: 2 bits
Type: Status
Suspect Parameter Number: 687
Parameter Group Number: [256]

spn688 - Disengage Differential Lock Request - Rear Axle 2 - Command signal used to disengage the various differential locks, e.g., to allow an undistributed individual wheel control by ABS. The differential locks are located as defined in Figure SPN564_A.

00 Engage differential lock
01 Disengage differential lock
11 Take no action

Bit Length: 2 bits
Type: Status
Suspect Parameter Number: 688
Parameter Group Number: [256]

spn689 - Disengage Differential Lock Request - Central - Command signal used to disengage the various differential locks, e.g., to allow an undistributed individual wheel control by ABS. The differential locks are located as defined in Figure SPN564_A.

00 Engage differential lock
01 Disengage differential lock
11 Take no action

Bit Length: 2 bits
Type: Status
Suspect Parameter Number: 689
Parameter Group Number: [256]

spn690 - Disengage Differential Lock Request - Central Front - Command signal used to disengage the various differential locks, e.g., to allow an undistributed individual wheel control by ABS. The differential locks are located as defined in Figure SPN564_A.

00 Engage differential lock
01 Disengage differential lock
11 Take no action

Bit Length: 2 bits
 Type: Status
 Suspect Parameter Number: 690
 Parameter Group Number: [256]

spn691 - Disengage Differential Lock Request - Central Rear - Command signal used to disengage the various differential locks, e.g., to allow an undistributed individual wheel control by ABS. The differential locks are located as defined in Figure SPN564_A.

00 Engage differential lock
 01 Disengage differential lock
 11 Take no action

Bit Length: 2 bits
 Type: Status
 Suspect Parameter Number: 691
 Parameter Group Number: [256]

spn692 - ABS Offroad Switch Request - Command signal used by the driver via a dashboard switch to choose the ABS offroad function.

00 Switch off ABS offroad function
 01 Switch on ABS offroad function
 11 Take no action

Bit Length: 2 bits
 Type: Status
 Suspect Parameter Number: 692
 Parameter Group Number: []

spn693 - ASR Offroad Switch Request - Command signal used by the driver via a dashboard switch to choose the ASR offroad function.

00 Switch off ASR offroad function
 01 Switch on ASR offroad function
 11 Take no action

Bit Length: 2 bits
 Type: Status
 Suspect Parameter Number: 693
 Parameter Group Number: []

spn694 - ASR "Hill Holder" Switch Request - Command signal used by the driver via a dashboard switch to choose a special ASR function.

00 Switch off ASR special function
 01 Switch on ASR special function
 11 Take no action

Bit Length: 2 bits
 Type: Status
 Suspect Parameter Number: 694
 Parameter Group Number: []

spn695 - Override Control Mode - The override control mode defines which sort of command is used:

00 Override disabled - Disable any existing control commanded by the source of this command.
 01 Speed control - Govern speed to the included 'desired speed' value.
 10 Torque control - Control torque to the included 'desired torque' value.

11 Speed/torque limit control - Limit speed and/or torque based on the included limit values. The speed limit governor is a droop governor where the speed limit value defines the speed at the maximum torque available during this operation.

If a device wants to know whether it has access to the engine, there are several possibilities:

- a. Comparing its command with the actual engine broadcasts.
- b. Looking at command modes from other devices.
- c. Looking to the engine and retarder torque mode.

Remarks:

- a. The realization of a torque limit (minimum selection) is possible by setting the speed limit to a high value (0xFAFF).
- b. The realization of a speed limit (minimum selection) is possible by setting the torque limit to a high value (0xFA).
- c. Limiting the retarder torque means to limit the magnitude of the torque request. As the brake torque is represented by negative torque values, the limitation must be done by a maximum selection of the requested torque and the retarder internal torque signals.
- d. For torque increasing functions, time limits for the torque or speed value (command) and the direct modes are desirable.
- e. The selection of which device has control of the engine's speed or torque depends on the override mode priority (see SPN 897) with the highest priority device gaining control. In the case of two devices with identical priority, the engine responds to speed/torque control commands over speed/torque limit commands and will act on the speed or torque commands on a first come, first served basis. The torque limit will be a 'lowest wins' selection (e.g., if one device commands 60% limit and another 80% limit, then the engine will limit torque to 60%). Figure SPN695_A provides a flowchart of the torque/speed control priority selection logic.

Bit Length:	2 bits
Type:	Status
Suspect Parameter Number:	695
Parameter Group Number:	[0]

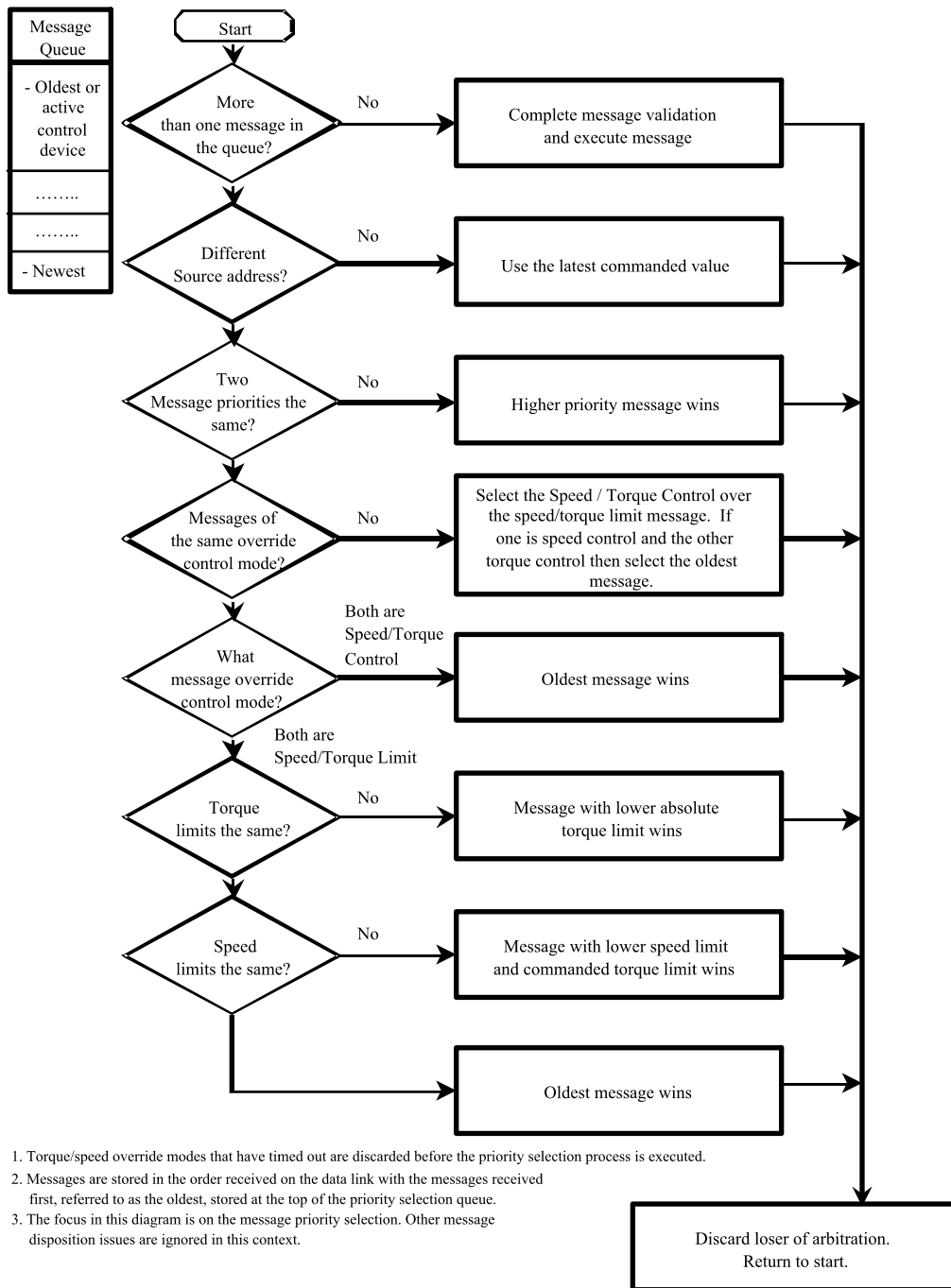

FIGURE SPN695_A -- TORQUE/SPEED CONTROL PRIORITY SELECTION LOGIC

spn696 - Requested Speed Control Conditions - This mode tells the engine control system the governor characteristics that are desired during speed control. The four characteristics defined are:

- 00 Transient Optimized for driveline disengaged and non-lockup conditions
- 01 Stability Optimized for driveline disengaged and non-lockup conditions
- 10 Stability Optimized for driveline engaged and/or in lockup condition 1 (e.g., vehicle driveline)
- 11 Stability Optimized for driveline engaged and/or in lockup condition 2 (e.g., PTO driveline)

00b - This speed governor gain selection is adjusted to provide rapid transition between speed setpoints. RPM overshoot and undershoot may be greater than what is seen when the 'speed control characteristic' is set to be stability optimized.

01b - This control condition has been optimized to minimize rpm overshoot and undershoot given an expected plant consisting of the engine and its accessory loads. This gain adjustment is not intended to compensate for driveline characteristics. This characteristic is most appropriate when no driveline is connected.

10b - This control condition has been optimized to minimize rpm overshoot and undershoot given a more complex plant. For instance, the more complex plant would contain the engine, its accessory loads and the driveline characteristics. As an example, the driveline characteristics might include the effective spring mass relationship of pumps, tires, clutches, axles, driveshafts, and multiple gear ratios. This characteristic is most appropriate when a driveline is engaged.

11b - This speed control characteristic is available for applications requiring compensation for more than one driveline characteristic. It has been optimized to minimize rpm overshoot and undershoot given a more complex plant of the second variety. This more complex plant would again contain the engine, its accessory loads and a second driveline characteristic unique from the one described in speed control characteristic 10b.

Bit Length: 2 bits
 Type: Status
 Suspect Parameter Number: 696
 Parameter Group Number: [0]

spn701 - Auxiliary I/O #01 - Identifies the current status of auxiliary input/output functions that are configured uniquely per application.

00 - Auxiliary channel off
 01 - Auxiliary channel on

Bit Length: 2 bits
 Type: Dependent upon Application
 Suspect Parameter Number: 701
 Parameter Group Number: [65241]

spn702 - Auxiliary I/O #02 - Identifies the current status of auxiliary input/output functions that are configured uniquely per application.

00 - Auxiliary channel off
 01 - Auxiliary channel on

Bit Length: 2 bits
 Type: Dependent upon Application
 Suspect Parameter Number: 702
 Parameter Group Number: [65241]

spn703 - Auxiliary I/O #03 - Identifies the current status of auxiliary input/output functions that are configured uniquely per application.

00 - Auxiliary channel off
 01 - Auxiliary channel on

Bit Length: 2 bits
 Type: Dependent upon Application
 Suspect Parameter Number: 703
 Parameter Group Number: [65241]

spn704 - Auxiliary I/O #04 - Identifies the current status of auxiliary input/output functions that are configured uniquely per application.

00 - Auxiliary channel off
 01 - Auxiliary channel on

Bit Length: 2 bits
 Type: Dependent upon Application
 Suspect Parameter Number: 704

Parameter Group Number: [65241]

spn705 - Auxiliary I/O #05 - Identifies the current status of auxiliary input/output functions that are configured uniquely per application.

- 00 - Auxiliary channel off
- 01 - Auxiliary channel on

Bit Length: 2 bits
 Type: Dependent upon Application
 Suspect Parameter Number: 705
 Parameter Group Number: [65241]

spn706 - Auxiliary I/O #06 - Identifies the current status of auxiliary input/output functions that are configured uniquely per application.

- 00 - Auxiliary channel off
- 01 - Auxiliary channel on

Bit Length: 2 bits
 Type: Dependent upon Application
 Suspect Parameter Number: 706
 Parameter Group Number: [65241]

spn707 - Auxiliary I/O #07 - Identifies the current status of auxiliary input/output functions that are configured uniquely per application.

- 00 - Auxiliary channel off
- 01 - Auxiliary channel on

Bit Length: 2 bits
 Type: Dependent upon Application
 Suspect Parameter Number: 707
 Parameter Group Number: [65241]

spn708 - Auxiliary I/O #08 - Identifies the current status of auxiliary input/output functions that are configured uniquely per application.

- 00 - Auxiliary channel off
- 01 - Auxiliary channel on

Bit Length: 2 bits
 Type: Dependent upon Application
 Suspect Parameter Number: 708
 Parameter Group Number: [65241]

spn709 - Auxiliary I/O #09 - Identifies the current status of auxiliary input/output functions that are configured uniquely per application.

- 00 - Auxiliary channel off
- 01 - Auxiliary channel on

Bit Length: 2 bits
 Type: Dependent upon Application
 Suspect Parameter Number: 709
 Parameter Group Number: [65241]

spn710 - Auxiliary I/O #10 - Identifies the current status of auxiliary input/output functions that are configured uniquely per application.

- 00 - Auxiliary channel off
- 01 - Auxiliary channel on

Bit Length: 2 bits
 Type: Dependent upon Application
 Suspect Parameter Number: 710
 Parameter Group Number: [65241]

spn711 - Auxiliary I/O #11 - Identifies the current status of auxiliary input/output functions that are configured uniquely per application.

- 00 - Auxiliary channel off
- 01 - Auxiliary channel on

Bit Length: 2 bits
 Type: Dependent upon Application
 Suspect Parameter Number: 711
 Parameter Group Number: [65241]

spn712 - Auxiliary I/O #12 - Identifies the current status of auxiliary input/output functions that are configured uniquely per application.

- 00 - Auxiliary channel off
- 01 - Auxiliary channel on

Bit Length: 2 bits
 Type: Dependent upon Application
 Suspect Parameter Number: 712
 Parameter Group Number: [65241]

spn713 - Auxiliary I/O #13 - Identifies the current status of auxiliary input/output functions that are configured uniquely per application.

- 00 - Auxiliary channel off
- 01 - Auxiliary channel on

Bit Length: 2 bits
 Type: Dependent upon Application
 Suspect Parameter Number: 713
 Parameter Group Number: [65241]

spn714 - Auxiliary I/O #14 - Identifies the current status of auxiliary input/output functions that are configured uniquely per application.

- 00 - Auxiliary channel off
- 01 - Auxiliary channel on

Bit Length: 2 bits
 Type: Dependent upon Application
 Suspect Parameter Number: 714
 Parameter Group Number: [65241]

spn715 - Auxiliary I/O #15 - Identifies the current status of auxiliary input/output functions that are configured uniquely per application.

- 00 - Auxiliary channel off

01 - Auxiliary channel on

Bit Length: 2 bits
 Type: Dependent upon Application
 Suspect Parameter Number: 715
 Parameter Group Number: [65241]

spn716 - Auxiliary I/O #16 - Identifies the current status of auxiliary input/output functions that are configured uniquely per application.

00 - Auxiliary channel off
 01 - Auxiliary channel on

Bit Length: 2 bits
 Type: Dependent upon Application
 Suspect Parameter Number: 716
 Parameter Group Number: [65241]

spn740 - Lockup Clutch Actuator - Identifies the status of the actuator that controls the lockup clutch.

00 - Off
 01 - On

Bit Length: 2 bits
 Type: Status
 Suspect Parameter Number: 740
 Parameter Group Number: [65223]

spn748 - Transmission Output Retarder - Identifies the status of the transmission output retarder.

00 - Off
 01 - On

Bit Length: 2 bits
 Type: Status
 Suspect Parameter Number: 748
 Parameter Group Number: [65218]

spn767 - Transmission Reverse Direction Switch - Identifies the status of the switch that indicates reverse direction.

00 - Off
 01 - On

Bit Length: 2 bits
 Type: Status
 Suspect Parameter Number: 767
 Parameter Group Number: [65219]

spn768 - Range High Actuator - Identifies the status of the range high actuator in the auxiliary unit.

00 -Off
 01 -On

Bit Length: 2 bits
 Type: Status
 Suspect Parameter Number: 768
 Parameter Group Number: [65223]

spn769 - Range Low Actuator - Identifies the status of the range low actuator in the auxiliary unit.

00 - Off
01 - On

Bit Length: 2 bits
Type: Status
Suspect Parameter Number: 769
Parameter Group Number: [65223]

spn770 - Splitter Direct Actuator - Identifies the status of the splitter direct actuator in the auxiliary unit.

00 - Off
01 - On

Bit Length: 2 bits
Type: Status
Suspect Parameter Number: 770
Parameter Group Number: [65223]

spn771 - Splitter Indirect Actuator - Identifies the status of the splitter indirect actuator in the auxiliary unit.

00 - Off
01 - On

Bit Length: 2 bits
Type: Status
Suspect Parameter Number: 771
Parameter Group Number: [65223]

spn772 - Shift Finger Rail Actuator 1 - Identifies the status of the actuator that moves the shift finger identified as rail actuator #1.

00 - Off
01 - On

Bit Length: 2 bits
Type: Status
Suspect Parameter Number: 772
Parameter Group Number: [65223]

spn773 - Shift Finger Gear Actuator 1 - Identifies the status of the actuator that moves the shift finger identified as gear actuator #1.

00 - Off
01 - On

Bit Length: 2 bits
Type: Status
Suspect Parameter Number: 773
Parameter Group Number: [65223]

spn778 - Transmission High Range Sense Switch - Identifies the status of the switch that represents high range.

00 - Off
01 - On

Bit Length: 2 bits
Type: Status
Suspect Parameter Number: 778
Parameter Group Number: [65219]

spn779 - Transmission Low Range Sense Switch - Identifies the status of the switch that represents low range.

00 - Off
01 - On

Bit Length: 2 bits
Type: Status
Suspect Parameter Number: 779
Parameter Group Number: [65219]

spn780 - Shift Finger Neutral Indicator - Indicates the status of the shift finger in the neutral position.

00 - Off
01 - On

Bit Length: 2 bits
Type: Status
Suspect Parameter Number: 780
Parameter Group Number: [65223]

spn781 - Shift Finger Engagement Indicator - Identifies the status of the shift finger in the engagement position.

00 - Off
01 - On

Bit Length: 2 bits
Type: Status
Suspect Parameter Number: 781
Parameter Group Number: [65223]

spn782 - Shift Finger Center Rail Indicator - Identifies the status of the shift finger in the center rail position.

00 - Off
01 - On

Bit Length: 2 bits
Type: Status
Suspect Parameter Number: 782
Parameter Group Number: [65223]

spn783 - Shift Finger Rail Actuator 2 - Identifies the status of the actuator that moves the shift finger identified as rail actuator #2.

00 - Off
01 - On

Bit Length: 2 bits
Type: Status
Suspect Parameter Number: 783
Parameter Group Number: [65223]

spn784 - Shift Finger Gear Actuator 2 - Identifies the status of the actuator that moves the shift finger identified as gear actuator #2.

00 - Off
01 - On

Bit Length: 2 bits
Type: Status
Suspect Parameter Number: 784

Parameter Group Number: [65223]

spn786 - Defuel Actuator - Identifies the status of the actuator that controls the engine defuel mechanism.

00 - Off

01 - On

Bit Length: 2 bits

Type: Status

Suspect Parameter Number: 786

Parameter Group Number: [65223]

spn787 - Inertia Brake Actuator - Identifies the status of the actuator that controls the inertia brake.

00 - Off

01 - On

Bit Length: 2 bits

Type: Status

Suspect Parameter Number: 787

Parameter Group Number: [65223]

spn788 - Clutch Actuator - Identifies the status of the actuator that controls the clutch.

00 - Off

01 - On

Bit Length: 2 bits

Type: Status

Suspect Parameter Number: 788

Parameter Group Number: [65223]

spn875 - Refrigerant Low Pressure Switch - Switch signal which indicates the position of the low pressure switch in the coolant circuit of an air conditioning system. When the switch is enabled, the pressure inside the circuit is too low and the compressor clutch may be disengaged.

00 - Pressure normal

01 - Pressure too low, compressor clutch may be disengaged

Bit Length: 2 bits

Type: Measured

Suspect Parameter Number: 875

Parameter Group Number: [65252]

spn897 - Override Control Mode Priority - This field is used as an input to the engine or retarder to determine the priority of the Override Control Mode received in the Torque/Speed Control message (see PGN 0). The default is 11 (Low priority). It is not required to use the same priority during the entire override function. For example, the transmission can use priority 01 (High priority) during a shift, but can set the priority to 11 (Low priority) at the end of the shift to allow traction control to also interact with the torque limit of the engine.

The four priority levels defined are:

00 Highest priority

01 High priority

10 Medium priority

11 Low priority

00b - Highest Priority = Used for situations that require immediate action by the receiving device in order to provide safe vehicle operation (i.e., braking systems). This level of priority should only be used in safety critical conditions.

01b - High Priority = Used for control situations that require prompt action in order to provide safe vehicle operation. An example is when the transmission is performing a shift and requires control of the engine in order to control driveline reengagement.

10b - Medium Priority = Used for powertrain control operations which are related to assuring that the vehicle is in a stable

operating condition. An example is when the traction control system is commanding the engine in order to achieve traction stability.

11b - Low Priority = Used to indicate that the associated command desires powertrain control but is needed for function which improves the driver comfort which may be overridden by other devices. An example is cruise control or the non-critical part of a transmission shift to a new gear.

Bit Length: 2 bits
 Type: Status
 Suspect Parameter Number: 897
 Parameter Group Number: [0]

spn898 - Requested Speed/Speed Limit - Parameter provided to the engine from external sources in the torque/speed control message. This is the engine speed which the engine is expected to operate at if the speed control mode is active or the engine speed which the engine is not expected to exceed if the speed limit mode is active.

Data Length: 2 bytes
 Resolution: 0.125 rpm/bit , 0 offset
 Data Range: 0 to 8,031.875 rpm
 Type: Status
 Suspect Parameter Number: 898
 Parameter Group Number: [0]

spn899 - Engine Torque Mode - State signal which indicates which engine torque mode is currently generating, limiting, or controlling the torque. Note that the modes are not in prioritized order. Not all modes may be relevant for a given device. Some devices may not implement all functions. For typical priorities refer to Figures SPN512_A and SPN512_B for engine control and Tables SPN518_A to SPN518_B for retarder control. The data type of this parameter is measured.

Mode 0000b means 'No request': engine torque may range from 0 to full load only due to low idle governor output; retarder torque = 0 (no braking).

Modes 0001b to 1110b indicate that there is either a torque request or the identified function is currently controlling the engine/retarder: engine/retarder torque may range from 0 (no fueling/no braking) to the upper limit.

Bit Length: 4 bits
 Type: Measured
 Suspect Parameter Number: 899
 Parameter Group Number: [61444]

Bit States	Engine/Retarder Torque Mode
0000	Low idle governor/no request (default mode)
0001	Accelerator pedal/operator selection
0010	Cruise control
0011	PTO governor
0100	Road speed governor
0101	ASR control
0110	Transmission control
0111	ABS control
1000	Torque limiting
1001	High speed governor
1010	Braking system
1011	Remote accelerator
1100	not defined
1101	not defined
1110	Other
1111	Not available

State Descriptions:

0000b Low Idle Governor/No request (Default mode) —This mode is active if the accelerator pedal (not necessarily the torque output of the driver input, see Figure SPN512_A and Figure SPN512_B) is zero. This is the default mode. At low speed, the low idle governor may be active while at higher speed, it is zero.

0001b Accelerator Pedal —This mode is active if the accelerator pedal position is active (being followed). This mode is active for the retarder if it is turned on by the operator. Note that it may be disabled by the accelerator pedal or clutch switches (operator selection).

0010b Cruise Control —This mode is active if cruise control is active and greater than the accelerator pedal request.

0011b PTO Governor —This mode is active if the PTO governor is active.

0100b Road Speed Governing —Indicates that road speed governing is active and limiting torque.

0101b ASR Control —Indicates that the ASR command is active (Speed, Torque, or Speed/Torque Limit Control).

0110b Transmission Control —Indicates that the transmission command is active (Speed, Torque, or Speed/Torque Limit Control).

0111b ABS Control —Indicates that the ABS is controlling torque.

1000b Torque Limiting —This mode is active if the demanded or commanded engine torque is limited by internal logic due to full load, smoke and/or emissions control, engine protection and/or other factors. A reduced torque limit may be necessary for engine protection if the engine temperature is too high or a sensor fails (speed, timing, or boost pressure), as examples.

1001b High Speed Governor —This mode is active if the engine is controlled by the high speed governor due to normal operation.

1010b Brake System (Electronic) —This indicates that the brake pedal is controlling the torque. Note that this may include enabling of the retarder when the brake pedal is depressed (touched).

Note that if there is a request to the retarder but operating conditions do not allow braking, this situation will be reflected by the Percent Retarder Torque = 0 when broadcast.

1011b Remote Accelerator —This mode is active if the remote accelerator is controlling engine speed.

1100b Other —Torque control by a type of device which is different than those defined in states 0000b to 1011b.

TABLE SPN899_A -- ENGINE/RETARDER TORQUE MODES

spn900 - Retarder Torque Mode - State signal which indicates which retarder torque mode is currently generating, limiting, or controlling the torque. Note that the modes are not in prioritized order. Not all modes may be relevant for a given device. Some devices may not implement all functions. For typical priorities refer to Figures SPN512_A and SPN512_B for engine control and Tables SPN518_A to SPN518_B for retarder control. The data type of this parameter is measured.

Mode 0000b means 'No request': engine torque may range from 0 to full load only due to low idle governor output; retarder torque = 0 (no braking).

Modes 0001b to 1110b indicate that there is either a torque request or the identified function is currently controlling the engine/retarder: engine/retarder torque may range from 0 (no fueling/no braking) to the upper limit.

Bit Length:	4 bits
Type:	Measured
Suspect Parameter Number:	900
Parameter Group Number:	[61440]

spn901 - Retarder Type - A vehicle retarder is a supplementary device to the wheel brakes for the driver to better control the vehicle. The wheel brakes used in the vehicle are not designed for continuous retarding operation. In a prolonged period of braking, the brakes can be thermally over-stressed, causing the braking effect to be reduced or even lead to complete braking system failure. The vehicle retarder is designed for continuous operation for braking during downhill operation and is also used for braking the vehicle to comply with speed limits and traffic conditions.

This parameter provides some indication of the retarder dynamics. It is used in the retarder configuration message (See PGN 65249). The data type of this parameter is measured.

Bit Length:	4 bits
Type:	Measured
Suspect Parameter Number:	901
Parameter Group Number:	[65249]

Bit States	Retarder Type
0000	Electric/Magnetic
0001	Hydraulic
0010	Cooled Friction
0011	Compression Release (Engine retarder)
0100	Exhaust
0101-1101	Not defined
1110	Other
1111	Not available

Electric/Magnetic Retarder—The electric/magnetic retarder functions by creating eddy currents generated in a conductive armature when placed in a variable magnetic field. Currently, electric retarders have a stator on which field coils are mounted. The rotors, mounted on both sides of the drive shaft, are ribbed for heat dissipation. In order to brake the vehicle, voltage is applied to the field coils which generate a magnetic field inducing eddy currents in the rotors as they pass through the field. Magnetic retarders use a permanent magnet to generate the eddy currents. Braking-torque is dependent on stator excitation and on the air gap between the rotor and the stator.

Hydraulic Retarder—The hydraulic retarder is a hydrodynamic coupling device. Two impellers which face each other, a rotor and a stator, are filled with oil. When the rotor, which is connected to the vehicle drive shaft rotates, it drives the oil in the direction of rotation. The mechanical energy produced by the rotor is converted into kinetic energy in the operating fluid. Hydrodynamic coupling between the rotor and stator converts the kinetic energy into heat and the rotor is retarded. This retardation effect is transmitted to the drive shaft and the vehicle is retarded.

Cooled Friction Brake—The cooled friction brake uses air or hydraulic fluid to dissipate heat from the friction surface of the service brake. By controlling the friction surface temperature, retarding torque is improved, along with a reduced rate of wear.

Compression Release Engine Retarder—The compression release engine retarder converts a power-producing diesel engine into a power-absorbing retarding mechanism by opening the exhaust valve near the top dead center in the engine compression cycle. No positive power will be produced, since the compressed air mass is released. The vehicle is retarded as it must provide energy to compress the cylinder air charge and subsequently to return the piston to the bottom position.

Exhaust Brake—The exhaust brake restricts the escape of the exhaust gas from the exhaust manifold. Each succeeding exhaust stroke builds up a back pressure in the manifold which exerts a retarding effect to the pistons during the exhaust stroke. The engine turns against this back pressure creating a braking effect to the vehicle.

Auxiliary Retarder—Fans, air conditioners, or any power-absorbing device in the vehicle can also function as retarders as they impose parasitic loading on the engine or vehicle.

TABLE SPN901_A -- RETARDER TYPES

spn902 - Retarder Location - This parameter defines whether the 'torque/speed curve' defined by the retarder configuration message (PGN 65249) is dependent on engine rpm, output shaft rpm, or other parameter. The data type of this parameter is measured.

This parameter defines whether the 'torque/speed curve' defined by the retarder configuration message (PGN 65249) is dependent on engine rpm, output shaft rpm, or other parameter. The data type of this parameter is measured.

Bit Length: 4 bits
 Type: Measured
 Suspect Parameter Number: 902
 Parameter Group Number: [65249]

Bit States	Retarder Location
0000 (Primary)	Engine Compression Release Brake (Engine rpm)
0001 (Primary)	Engine Exhaust Brake (Exhaust pressure)
0010 (Primary)	Transmission Input (Engine rpm)
0011 (Secondary)	Transmission Output (Output Shaft rpm)
0100 (Secondary)	Driveline (Output Shaft rpm)
0101	Trailer (Vehicle speed)
0110-1101	Not defined
1110	Other
1111	Not available

TABLE SPN902_A -- RETARDER LOCATION

spn903 - Transmission Forward Direction Switch - Identifies the status of the switch that indicates forward direction.

00 - Off
01 - On

Bit Length: 2 bits
Type: Status
Suspect Parameter Number: 903
Parameter Group Number: [65219]

spn904 - Front Axle Speed - The average speed of the two front wheels.

Data Length: 2 bytes
Resolution: 1/256 km/h per bit , 0 offset
Data Range: 0 to 250.996 km/h
Type: Measured
Suspect Parameter Number: 904
Parameter Group Number: [65215]

spn905 - Relative Speed; Front Axle, Left Wheel - The speed of the front axle, left wheel relative to the front axle speed, SPN 904.

Data Length: 1 byte
Resolution: 1/16 km/h per bit , -7.8125 km/h offset
Data Range: -7.8125 to 7.8125 km/h
Type: Measured
Suspect Parameter Number: 905
Parameter Group Number: [65215]

spn906 - Relative Speed; Front Axle, Right Wheel - The speed of the front axle, right wheel relative to the front axle speed, SPN 904.

Data Length: 1 byte
Resolution: 1/16 km/h per bit , -7.8125 km/h offset
Data Range: -7.8125 to 7.8125 km/h
Type: Measured
Suspect Parameter Number: 906
Parameter Group Number: [65215]

spn907 - Relative Speed; Rear Axle #1, Left Wheel - The speed of the rear axle #1, left wheel relative to the front

axle speed, SPN 904.

Data Length: 1 byte
 Resolution: 1/16 km/h per bit , -7.8125 km/h offset
 Data Range: -7.8125 to 7.8125 km/h
 Type: Measured
 Suspect Parameter Number: 907
 Parameter Group Number: [65215]

spn908 - Relative Speed; Rear Axle #1, Right Wheel - The speed of the rear axle #1, right wheel relative to the front axle speed, SPN 904.

Data Length: 1 byte
 Resolution: 1/16 km/h per bit , -7.8125 km/h offset
 Data Range: -7.8125 to 7.8125 km/h
 Type: Measured
 Suspect Parameter Number: 908
 Parameter Group Number: [65215]

spn909 - Relative Speed; Rear Axle #2, Left Wheel - The speed of the rear axle #2, left wheel relative to the front axle speed, SPN 904.

Data Length: 1 byte
 Resolution: 1/16 km/h per bit , -7.8125 km/h offset
 Data Range: -7.8125 to 7.8125 km/h
 Type: Measured
 Suspect Parameter Number: 909
 Parameter Group Number: [65215]

spn910 - Relative Speed; Rear Axle #2, Right Wheel - The speed of the rear axle #2, right wheel relative to the front axle speed, SPN 904.

Data Length: 1 byte
 Resolution: 1/16 km/h per bit , -7.8125 km/h offset
 Data Range: -7.8125 to 7.8125 km/h
 Type: Measured
 Suspect Parameter Number: 910
 Parameter Group Number: [65215]

spn911 - Service Component Identification - Identification of component needing service. See Table SPN911_A.

Data Length: 1 byte
 Resolution: 1 ID/bit , 0 offset
 Data Range: 0 to 250 ID
 Type: Measured
 Suspect Parameter Number: 911
 Parameter Group Number: [65216]

Identification	Component
0	Service check for entire vehicle
1	Brake lining; left front axle
2	Brake lining; right front axle
3	Brake lining; left rear axle
4	Brake lining; right rear axle
5	Clutch lining
6-10	Not defined
11	Brake lining; left rear axle #2
12	Brake lining; right rear axle #2
13	Brake lining; left rear axle #3
14	Brake lining; right rear axle #3
15	Brake lining: general
16	Regulated general check for entire vehicle
17	Brake system special check
18	In-between check
19	Check trip recorder
20	Check exhaust gas
21	Check vehicle speed limiter
22-29	Not defined
30	Engine coolant change
31	Engine coolant filter change
32	Engine oil —engine #1
33	Engine oil —engine #2
34	Not defined
35	Steering oil
36	Not defined
37	Transmission oil —transmission #1
38	Transmission oil —transmission #2
39	Not defined
40	Intermediate transmission oil
41	Not defined
42	Front axle oil
43	Rear axle oil
44-47	Not defined
48	Tires
49	Engine air filter
50	Engine oil filter
51-60	Not defined
61	Tachograph
62	Driver card #1
63	Driver card #2
64-239	Not defined
240-249	Manufacturer specific
250-251	Reserved
252	Reset all components
253	No action to be taken
254	Error
255	Component identification not available

TABLE SPN911_A -- SERVICE COMPONENT IDENTIFICATION

spn912 - Service Component Identification - Identification of component needing service. See Table SPN911_A.

Data Length: 1 byte
 Resolution: 1 ID/bit , 0 offset
 Data Range: 0 to 250 ID
 Type: Measured
 Suspect Parameter Number: 912
 Parameter Group Number: [65216]

spn913 - Service Component Identification - Identification of component needing service. See Table SPN911_A.

Data Length: 1 byte

Resolution: 1 ID/bit , 0 offset
 Data Range: 0 to 250 ID
 Type: Measured
 Suspect Parameter Number: 913
 Parameter Group Number: [65216]

spn914 - Service Distance - The distance which can be traveled by the vehicle before the next service inspection is required. A negative distance is transmitted if the service inspection has been passed. The component that requires service is identified by the service component identification (see SPN 911-913, 1379, and 1584).

Data Length: 2 bytes
 Resolution: 5 km/bit , -160,635 km offset
 Data Range: -160,635 to 160,640 km
 Type: Measured
 Suspect Parameter Number: 914
 Parameter Group Number: [65216]

spn915 - Service Delay/Calendar Time Based - The time in weeks until the next vehicle service inspection is required. A negative value is transmitted if the service inspection has been passed. The component that requires service is identified by the service component identification (see SPN 911-913, 1379, and 1584).

Data Length: 1 byte
 Resolution: 1 week/bit , -125 weeks offset
 Data Range: -125 to 125 weeks
 Type: Measured
 Suspect Parameter Number: 915
 Parameter Group Number: [65216]

spn916 - Service Delay/Operational Time Based - The time in vehicle operational time until the next vehicle service inspection is required. A negative value is transmitted if the service inspection has been passed. The component that requires service is identified by the service component identification (see SPN 911-913, 1379, and 1584).

Data Length: 2 bytes
 Resolution: 1 hr/bit , -32,127 hr offset
 Data Range: -32,127 to 32,128 hr
 Type: Measured
 Suspect Parameter Number: 916
 Parameter Group Number: [65216]

spn917 - High Resolution Total Vehicle Distance - Accumulated distance traveled by the vehicle during its operation. NOTE - See SPN 245 for alternate resolution.

Data Length: 4 bytes
 Resolution: 5 m/bit , 0 offset
 Data Range: 0 to 21,055,406 km
 Type: Measured
 Suspect Parameter Number: 917
 Parameter Group Number: [65217]

spn918 - High Resolution Trip Distance - Distance traveled during all or part of a journey. NOTE - See SPN 244 for alternate resolution.

Data Length:	4 bytes
Resolution:	5 m/bit , 0 offset
Data Range:	0 to 21,055,406 km
Type:	Measured
Suspect Parameter Number:	918
Parameter Group Number:	[65217]

spn927 - Location - To identify to which of several similar devices (such as tires or fuel tanks) the information applies.

The low order 4 bits represent a position number, counting left to right when facing in the direction of normal vehicle travel (forward).

The high order 4 bits represent a position number, counting front to back on the vehicle.

The value 0xFF indicates not available.

It is recommended that output devices add 1 to the position number (range 1 to 15, not 0 to 14) for use by drivers and service technicians.

Examples: Tire pressure for location 0x00 would be left front tire.

Tire pressure for location 0x23 would be right outside rear rear on a 3-axle tractor with dual axle per side (3rd axle, 4th tire).

Bit Length:	8 bits
Type:	Measured
Suspect Parameter Number:	927
Parameter Group Number:	[61446]

spn928 - Axle Location - To identify to which of several similar devices (such as tires or fuel tanks) the information applies.

The low order 4 bits represent a position number, counting left to right when facing in the direction of normal vehicle travel (forward).

The high order 4 bits represent a position number, counting front to back on the vehicle.

The value 0xFF indicates not available.

It is recommended that output devices add 1 to the position number (range 1 to 15, not 0 to 14) for use by drivers and service technicians.

Examples: Tire pressure for location 0x00 would be left front tire.

Tire pressure for location 0x23 would be right outside rear rear on a 3-axle tractor with dual axle per side (3rd axle, 4th tire).

Bit Length:	8 bits
Type:	Measured
Suspect Parameter Number:	928
Parameter Group Number:	[65258]

spn929 - Tire Location - To identify to which of several similar devices (such as tires or fuel tanks) the information applies.

The low order 4 bits represent a position number, counting left to right when facing in the direction of normal vehicle travel (forward).

The high order 4 bits represent a position number, counting front to back on the vehicle.

The value 0xFF indicates not available.

It is recommended that output devices add 1 to the position number (range 1 to 15, not 0 to 14) for use by drivers and service technicians.

Examples: Tire pressure for location 0x00 would be left front tire.

Tire pressure for location 0x23 would be right outside rear rear on a 3-axle tractor with dual axle per side (3rd axle, 4th tire).

Bit Length:	8 bits
Type:	Measured
Suspect Parameter Number:	929
Parameter Group Number:	[65268]

spn930 - Drive Axle Location - To identify to which of several similar devices (such as tires or fuel tanks) the information applies.

The low order 4 bits represent a position number, counting left to right when facing in the direction of normal vehicle travel (forward).

The high order 4 bits represent a position number, counting front to back on the vehicle.

The value 0xFF indicates not available.

It is recommended that output devices add 1 to the position number (range 1 to 15, not 0 to 14) for use by drivers and service technicians.

Examples: Tire pressure for location 0x00 would be left front tire.

Tire pressure for location 0x23 would be right outside rear rear on a 3-axle tractor with dual axle per side (3rd axle, 4th tire).

Bit Length: 8 bits
 Type: Measured
 Suspect Parameter Number: 930
 Parameter Group Number: [65273]

spn957 - Number of Forward Gear Ratios - Number of forward gear ratios in the transmission, provided as part of the configuration.

Data Length: 1 byte
 Resolution: 1 gear value/bit , 0 offset
 Data Range: 0 to 250
 Operating Range: 0 to 125 gear ratios
 Type: Measured
 Suspect Parameter Number: 957
 Parameter Group Number: [65250]

spn958 - Number of Reverse Gear Ratios - Number of reverse gear ratios in the transmission, provided as part of the transmission configuration.

Data Length: 1 byte
 Resolution: 1 gear value/bit , 0 offset
 Data Range: 0 to 250
 Operating Range: 0 to 125 gear ratios
 Type: Measured
 Suspect Parameter Number: 958
 Parameter Group Number: [65250]

spn959 - Seconds - Part of a parameter used to represent time.

Data Length: 1 byte
 Resolution: 0.25 s/bit , 0 offset
 Data Range: 0 to 62.5 s
 Operating Range: 0 to 59.75 sec
 Type: Measured
 Suspect Parameter Number: 959
 Parameter Group Number: [65254]

spn960 - Minutes - Part of a parameter used to represent time.

Data Length: 1 byte
 Resolution: 1 min/bit , 0 offset
 Data Range: 0 to 250 mins
 Operating Range: 0 to 59 min

Type: Measured
 Suspect Parameter Number: 960
 Parameter Group Number: [65254]

spn961 - Hours - Part of a parameter used to represent time.

Data Length: 1 byte
 Resolution: 1 hr/bit , 0 offset
 Data Range: 0 to 250 hr
 Operating Range: 0 to 23 hr
 Type: Measured
 Suspect Parameter Number: 961
 Parameter Group Number: [65254]

spn962 - Day - Part of a parameter used to represent a calendar date. NOTE - A value of 0 for the date is null. The values 1, 2, 3, and 4 are used to identify the first day of the month; 5, 6, 7, and 8 identify the second day of the month; etc.

Data Length: 1 byte
 Resolution: 0.25 days/bit , 0 offset
 Data Range: 0 to 62.5 days
 Operating Range: 0.25 to 31.75 day
 Type: Measured
 Suspect Parameter Number: 962
 Parameter Group Number: [65254]

spn963 - Month - Part of a parameter used to represent a calendar date. NOTE - A value of 0 for the month is null. The value 1 identifies January; 2 identifies February; etc.

Data Length: 1 byte
 Resolution: 1 month/bit , 0 offset
 Data Range: 0 to 250 months
 Operating Range: 1 to 12 month
 Type: Measured
 Suspect Parameter Number: 963
 Parameter Group Number: [65254]

spn964 - Year - Part of a parameter used to represent a calendar date. NOTE - A value of 0 for the year identifies the year 1985; a value of 1 identifies 1986; etc.

Data Length: 1 byte
 Resolution: 1 year/bit , 1985 years offset
 Data Range: 1985 to 2235 years
 Type: Measured
 Suspect Parameter Number: 964
 Parameter Group Number: [65254]

spn965 - Number of Software Identification Fields - Number of software identification designators represented in the software identification parameter group.

Data Length: 1 byte
 Resolution: 1 step/bit , 0 offset
 Data Range: 0 to 250 steps
 Operating Range: 0 to 125
 Type: Measured
 Suspect Parameter Number: 965
 Parameter Group Number: [65242]

spn966 - Engine Test Mode Switch - Switch signal which indicates the position of the engine test mode switch.

00 - Off
 01 - On

Bit Length: 2 bits
 Type: Measured
 Suspect Parameter Number: 966
 Parameter Group Number: [65265]

spn967 - Idle Decrement Switch - Switch signal which indicates the position of the idle decrement switch.

00 - Off
 01 - On

Bit Length: 2 bits
 Type: Measured
 Suspect Parameter Number: 967
 Parameter Group Number: [65265]

spn968 - Idle Increment Switch - Switch signal which indicates the position of the idle increment switch.

00 - Off
 01 - On

Bit Length: 2 bits
 Type: Measured
 Suspect Parameter Number: 968
 Parameter Group Number: [65265]

spn969 - Remote Accelerator Enable Switch - Switch signal which indicates that the remote accelerator has been enabled and controls the engine.

00 - Off
 01 - On

NOTE: The accelerator interlock switch (see SPN 972) must be disabled in order for the remote accelerator to perform engine control.

Bit Length: 2 bits
 Type: Measured
 Suspect Parameter Number: 969
 Parameter Group Number: [61441]

spn970 - Auxiliary Engine Shutdown Switch - Switch signal which requests that all engine fueling stop.

00 - Off
 01 - On

Bit Length: 2 bits
 Type: Measured

Suspect Parameter Number: 970
 Parameter Group Number: [61441]

spn971 - Engine Derate Switch - Switch signal used to activate the torque limiting feature of the engine. The specific nature of torque limiting should be verified with the manufacturer.

00 - Off
 01 - On

Bit Length: 2 bits
 Type: Measured
 Suspect Parameter Number: 971
 Parameter Group Number: [61441]

spn972 - Accelerator Interlock Switch - Switch signal used to disable the accelerator and remote accelerator inputs, causing the engine to return to idle.

00 - Off
 01 - On

Bit Length: 2 bits
 Type: Measured
 Suspect Parameter Number: 972
 Parameter Group Number: [61441]

spn973 - Engine Retarder Selection - The position of the operator controlled selector, expressed as a percentage and determined by the ratio of the current position of the selector to its maximum possible position. Zero percent means no braking torque is requested by the operator from the engine while 100% means maximum braking.

Data Length: 1 byte
 Resolution: 0.4 %/bit , 0 offset
 Data Range: 0 to 100 %
 Type: Measured
 Suspect Parameter Number: 973
 Parameter Group Number: [61441]

spn974 - Remote Accelerator Pedal Position - The ratio of actual position of the remote analog engine speed/torque request input device (such as an accelerator pedal or throttle lever) to the maximum position of the input device. For example, in on-highway vehicles this could be an accelerator control device that is external to the drivers cab or an accelerator that is controlled by a hand lever from the operators seat. The Remote Accelerator Enable Switch is SPN 969. This parameter enables the remote accelerator operation. NOTE: See SPNs 28, 29, and 91 for additional accelerator position parameters. If only one accelerator position exists on a vehicle, SPN 91 shall be used

Data Length: 1 byte
 Resolution: 0.4 %/bit , 0 offset
 Data Range: 0 to 100 %
 Type: Measured
 Suspect Parameter Number: 974
 Parameter Group Number: [61443]

spn975 - Estimated Percent Fan Speed - Estimated fan speed as a ratio of the fan drive (current speed) to the fully engaged fan drive (maximum fan speed). A two state fan (off/on) will use 0% and 100% respectively. A three state fan

(off/intermediate/on) will use 0%, 50% and 100% respectively. A variable speed fan will use 0% to 100%. Multiple fan systems will use 0 to 100% to indicate the percent cooling capacity being provided. Note that the intermediate fan speed of a three state fan will vary with different fan drives, therefore 50% is being used to indicate that the intermediate speed is required from the fan drive.

Data Length: 1 byte
 Resolution: 0.4 %/bit , 0 offset
 Data Range: 0 to 100 %
 Type: Status
 Suspect Parameter Number: 975
 Parameter Group Number: [65213]

spn976 - PTO State - This parameter is used to indicate the current state or mode of operation by the power takeoff (PTO) device. It needs to be ensured that each achieved state information be set up to be conveyed in at least one datalink message before a transition to another state is allowed. The Suspect Parameter Number for this parameter is 976.

This parameter is used to indicate the current state or mode of operation by the power takeoff (PTO) device. It needs to be ensured that each achieved state information be set up to be conveyed in at least one datalink message before a transition to another state is allowed. The Suspect Parameter Number for this parameter is 976.

Bit Length: 5 bits
 Type: Status
 Suspect Parameter Number: 976
 Parameter Group Number: [65265]

Bit States	PTO State
00000	Off/Disabled
00001	Hold
00010	Remote Hold
00011	Standby
00100	Remote Standby
00101	Set
00110	Decelerate/Coast
00111	Resume
01000	Accelerate
01001	Accelerator Override
01010	Preprogrammed set speed 1
01011	Preprogrammed set speed 2
01100	Preprogrammed set speed 3
01101	Preprogrammed set speed 4
01110	Preprogrammed set speed 5
01111	Preprogrammed set speed 6
10000	Preprogrammed set speed 7
10001	Preprogrammed set speed 8
10010-11110	Not defined
11111	Not available

- Off/Disabled 00000b —Used to indicate that the PTO enable switch is in the off position.
- Hold 00001b —Used to indicate that the PTO device is active and currently maintaining a captured operating speed.
- Remote Hold 00010b —Used to indicate that the remote PTO device is active and currently maintaining a captured operating speed.
- Standby 00011b —Used to indicate that the PTO device enable switch is in the ON position and it is possible to manage the PTO device.
- Remote Standby 00100b —Used to indicate that the remote PTO device enable switch is in the ON position and it is possible to manage the PTO device.
- Set 00101b —Used to indicate that the PTO device is establishing current speed as the operating speed (captured value).
- Decelerate/Coast 00110b —Used to indicate that the PTO device is in the process of ramping down, or coasting, from the current operating speed.
- Resume 00111b —Used to indicate that the PTO device is in the process of resuming the operating speed to a previously captured value.
- Accelerate 01000b —Used to indicate that the PTO device is in the process of ramping up the operating speed.
- Accelerator Override 01001b —Used to indicate that the PTO device is active but for the present time the engine is controlled by a large driver's demand.
- Preprogrammed Set Speed 1 01010b —Used to indicate that the PTO device is establishing a first preprogrammed set speed (user programmable) as the current operating speed.
- Preprogrammed Set Speed 2 01011b —Used to indicate that the PTO device is establishing a second preprogrammed set speed (user programmable) as the current operating speed.
- Preprogrammed Set Speed 3 01100b —Used to indicate that the remote PTO device is establishing a third preprogrammed set speed (user programmable) as the current operating speed.
- Preprogrammed Set Speed 4 01101b —Used to indicate that the remote PTO device is establishing a fourth preprogrammed set speed (user programmable) as the current operating speed.
- Preprogrammed Set Speed 5 01110b —Used to indicate that the remote PTO device is establishing a fifth preprogrammed set speed (user programmable) as the current operating speed.
- Preprogrammed Set Speed 6 01111b —Used to indicate that the remote PTO device is establishing a sixth preprogrammed set speed (user programmable) as the current operating speed.
- Preprogrammed Set Speed 7 10000b —Used to indicate that the remote PTO device is establishing a seventh preprogrammed set speed (user programmable) as the current operating speed.
- Preprogrammed Set Speed 8 10001b-- Used to indicate that the remote PTO device is establishing a eighth preprogrammed set speed (user programmable) as the current operating speed.

TABLE SPN976_A -- PTO STATES

spn977 - Fan Drive State - This parameter is used to indicate the current state or mode of operation by the fan drive.

- 0000 Fan off
- 0001 Engine system/General
- 0010 Excessive engine air temperature
- 0011 Excessive engine oil temperature
- 0100 Excessive engine coolant temperature
- 0101 Excessive transmission oil temperature
- 0110 Excessive hydraulic oil temperature
- 0111 Default Operation

1000 Not defined
 1001 Manual control
 1010 Transmission retarder
 1011 A/C system
 1100 Timer
 1101 Engine brake
 1110 Other
 1111 Not available
 Fan off 0000b 'Used to indicate that the fan clutch is disengaged and the fan is inactive
 Engine system'General 0001b 'Used to indicate that the fan is active due to an engine system not otherwise defined.
 Excessive engine air temperature 0010b 'Used to indicate that the fan is active due to high air temperature.
 Excessive engine oil temperature 0011b 'Used to indicate that the fan is active due to high oil temperature.
 Excessive engine coolant temperature 0100b 'Used to indicate that the fan is active due to high coolant temperature.
 Manual control 1001b 'Used to indicate that the fan is active as requested by the operator.
 Transmission retarder 1010b 'Used to indicate that the fan is active as required by the transmission retarder.
 A/C system 1011b 'Used to indicate that the fan is active as required by the air conditioning system.
 Timer 1100b 'Used to indicate that the fan is active as required by a timing function.
 Engine brake 1101b 'Used to indicate that the fan is active as required to assist engine braking.
 Excessive transmission oil temperature - 0101b - Used to indicate fan is active due to excessive transmission oil temperature.
 Excessive hydraulic oil temperature - 0110b - Used to indicate fan is active due to excessive hydraulic oil temperature.
 Default Operation - 0111b - Used to indicate fan is active due to a error condition resulting in default operation

Bit Length: 4 bits
 Type: Status
 Suspect Parameter Number: 977
 Parameter Group Number: [65213]

spn978 - Remote PTO Variable Speed Control Switch - Switch signal which indicates that the remote PTO toggle switch is in the enabled (ON) position. If the toggle switch is enabled and other conditions are satisfied then the remote PTO control feature is activated and the PTO will control at a variable speed.

00 - Off
 01 - On

Bit Length: 2 bits
 Type: Measured
 Suspect Parameter Number: 978
 Parameter Group Number: [65264]

spn979 - Remote PTO Preprogrammed Speed Control Switch - Switch signal which indicates that the remote PTO toggle switch is in the enabled (ON) position. If the toggle switch is enabled and other conditions are satisfied then the remote PTO control feature is activated and the PTO will control at the preprogrammed speed.

00 - Off
 01 - On

Bit Length: 2 bits
 Type: Measured
 Suspect Parameter Number: 979
 Parameter Group Number: [65264]

spn980 - PTO Enable Switch - Switch signal which indicates that the PTO toggle switch is in the enabled (ON) position and therefore it is possible to manage the PTO control function.

00 - Off
 01 - On

Bit Length: 2 bits
 Type: Measured
 Suspect Parameter Number: 980
 Parameter Group Number: [65264]

spn981 - PTO Accelerate Switch - Switch signal of the PTO control activator which indicates that the activator is in the position "accelerate".

00 - Off
01 - On

Bit Length: 2 bits
Type: Measured
Suspect Parameter Number: 981
Parameter Group Number: [65264]

spn982 - PTO Resume Switch - Switch signal of the PTO control activator which indicates that the activator is in the position "resume".

00 - Off
01 - On

Bit Length: 2 bits
Type: Measured
Suspect Parameter Number: 982
Parameter Group Number: [65264]

spn983 - PTO Coast/Decelerate Switch - Switch signal of the PTO control activator which indicates that the activator is in the position "coast/decelerate".

00 - Off
01 - On

Bit Length: 2 bits
Type: Measured
Suspect Parameter Number: 983
Parameter Group Number: [65264]

spn984 - PTO Set Switch - Switch signal of the PTO control activator which indicates that the activator is in the position "set".

00 - Off
01 - On

Bit Length: 2 bits
Type: Measured
Suspect Parameter Number: 984
Parameter Group Number: [65264]

spn985 - A/C High Pressure Fan Switch - Switch signal which indicates that the pressure in the coolant circuit of an air conditioning system is high and the fan may be engaged.

00 - Pressure normal
01 - Pressure high, fan may be engaged

Bit Length: 2 bits
Type: Measured
Suspect Parameter Number: 985
Parameter Group Number: [65252]

spn986 - Requested Percent Fan Speed - Fan speed as a ratio of the actual fan drive (current speed) to the fully engaged fan drive (maximum fan speed). A two state fan (off/on) will use 0% and 100% respectively. A three state fan (off/intermediate/on) will use 0%, 50% and 100% respectively. A variable speed fan will use 0% to 100%. Multiple fan systems will use 0 to 100% to indicate the

percent cooling capacity being provided. Feedback to this request is provided using the estimated fan speed (see SPN 975). Note that the intermediate fan speed of a three state fan will vary with different fan drives, therefore 50% is being used to indicate that the intermediate speed is required from the fan drive.

Data Length: 1 byte
 Resolution: 0.4 %/bit , 0 offset
 Data Range: 0 to 100 %
 Type: Status
 Suspect Parameter Number: 986
 Parameter Group Number: [57344]

spn988 - Trip Group 1 - Command signal used to reset the PGNs and parameters as defined in Table SPN988_A.

- 00 Take no action
- 01 Reset
- 11 Not applicable

Bit Length: 2 bits
 Type: Status
 Suspect Parameter Number: 988
 Parameter Group Number: [56832]

Parameter	SPN
Trip distance	244
Trip fuel	182
High resolution trip distance	918
Trip compression brake distance	990
Trip service brake applications	993
Trip maximum engine speed	1013
Trip average engine speed	1014
Trip drive average load factor	1015
Trip average fuel rate	1029
Trip average fuel rate (Gaseous)	1031
Parameter Group	PGN
Trip time information #2	65,200
Trip time information #1	65,204
Trip shutdown information	65,205
Trip vehicle speed/cruise distance information	65,206
Trip fuel information (Gaseous)	65,208
Trip fuel information	65,209
Trip distance information	65,210
Trip fan information	65,211

TABLE 988_A -- TRIP GROUP 1

spn989 - Trip Group 2 - Proprietary - Command signal used to reset proprietary parameters associated with a trip but not defined within this document.

- 00 Take no action
- 01 Reset
- 11 Not applicable

Bit Length: 2 bits
 Type: Status
 Suspect Parameter Number: 989
 Parameter Group Number: [56832]

spn990 - Total Compression Brake Distance - Total distance over which the compression brakes have been active for

the life of the engine.

Data Length: 4 bytes
 Resolution: 0.125 km/bit , 0 offset
 Data Range: 0 to 526,385,151.9 km
 Type: Measured
 Suspect Parameter Number: 990
 Parameter Group Number: [65212]

spn991 - Trip Compression Brake Distance - Total distance over which the compression brakes have been active since the last trip reset.

Data Length: 4 bytes
 Resolution: 0.125 km/bit , 0 offset
 Data Range: 0 to 526,385,151.9 km
 Type: Measured
 Suspect Parameter Number: 991
 Parameter Group Number: [65212]

spn992 - Trip Service Brake Distance - Total distance over which the service brakes have been active since the last trip reset.

Data Length: 4 bytes
 Resolution: 0.125 km/bit , 0 offset
 Data Range: 0 to 526,385,151.9 km
 Type: Measured
 Suspect Parameter Number: 992
 Parameter Group Number: [65212]

spn993 - Trip Service Brake Applications - Total number of times the service brakes have been activated since the last trip reset. Brake applications of less than 0.5 s are not counted and lengthy brake applications (longer than 0.5 s) are counted as a single event. NOTE - Definition and resolution shall stay the same if brakes are applied by only the tractor, only the trailer or both.

Data Length: 4 bytes
 Resolution: 1 brake appl/bit , 0 offset
 Data Range: 0 to 4,227,858,431 appl
 Type: Measured
 Suspect Parameter Number: 993
 Parameter Group Number: [65212]

spn994 - Trip Fan On Time - Total time the fan has been on (due to an automatic trigger or manual trigger) since the last trip reset. The fan could be requested to be on by the engine system, a manual switch, and/or the A/C system. Whichever system requests the fan activation first shall have the time accumulated against it. The sum total of these three values shall equal the trip fan on time. NOTE: If the fan has been requested to be on by a component that is not one of the defined categories, this time shall be accumulated in the Engine System category by default.

Data Length: 4 bytes
 Resolution: 0.05 hr/bit , 0 offset
 Data Range: 0 to 210,554,060.75 hr

Type: Measured
 Suspect Parameter Number: 994
 Parameter Group Number: [65211]

spn995 - Trip Fan On Time Due to the Engine System - Total time the fan has been on due to engine triggers (i.e., excluding time on due to an operator manual switch or A/C system) since the last trip reset. For the time to be accumulated against the engine system, it is necessary that it be the first to request the fan activation or it be the only system requesting fan activation.

Data Length: 4 bytes
 Resolution: 0.05 hr/bit , 0 offset
 Data Range: 0 to 210,554,060.75 hr
 Type: Measured
 Suspect Parameter Number: 995
 Parameter Group Number: [65211]

spn996 - Trip Fan On Time Due to a Manual Switch - Total time the fan has been on due to manual activation by the operator (i.e., excluding time on due to automatic triggers) since the last trip reset. For the time to be accumulated against the manual switch, it is necessary that it be the first to request the fan activation or it be the only system requesting fan activation.

Data Length: 4 bytes
 Resolution: 0.05 hr/bit , 0 offset
 Data Range: 0 to 210,554,060.75 hr
 Type: Measured
 Suspect Parameter Number: 996
 Parameter Group Number: [65211]

spn997 - Trip Fan On Time Due to the A/C System - Total time the fan has been on due to the A/C system since the last trip reset. For the time to be accumulated against the A/C system, it is necessary that it be the first to request the fan activation or it be the only system requesting fan activation.

Data Length: 4 bytes
 Resolution: 0.05 hr/bit , 0 offset
 Data Range: 0 to 210,554,060.75 hr
 Type: Measured
 Suspect Parameter Number: 997
 Parameter Group Number: [65211]

spn998 - Trip Distance on VSL - Total distance accumulated while the engine torque mode is road speed governing since the last trip reset.

Data Length: 4 bytes
 Resolution: 0.125 km/bit , 0 offset
 Data Range: 0 to 526,385,151.9 km
 Type: Measured
 Suspect Parameter Number: 998
 Parameter Group Number: [65210]

spn999 - Trip Gear Down Distance - Total distance accumulated while the vehicle has operated in the gear which is one

gear down from top gear and exceeds a calibrated minimum time (typically the time to shift the transmission) since the last trip reset.

Data Length: 4 bytes
 Resolution: 0.125 km/bit , 0 offset
 Data Range: 0 to 526,385,151.9 km
 Type: Measured
 Suspect Parameter Number: 999
 Parameter Group Number: [65210]

spn1000 - Trip Distance in Top Gear - Total distance accumulated while the vehicle has operated in top gear for a calibrated minimum time since the last trip reset.

Data Length: 4 bytes
 Resolution: 0.125 km/bit , 0 offset
 Data Range: 0 to 526,385,151.9 km
 Type: Measured
 Suspect Parameter Number: 1000
 Parameter Group Number: [65210]

spn1001 - Trip Drive Fuel Used - Total fuel consumed while the engine speed is greater than zero, vehicle speed is greater than or equal to 2 km/h, and neither the PTO or the remote PTO is controlling the engine power output, since the last trip reset. NOTE: This parameter is intended for liquid fueled engines. See SPN 1007 for alternate resolution.

Data Length: 4 bytes
 Resolution: 0.5 L/bit , 0 offset
 Data Range: 0 to 2,105,540,607.5 L
 Type: Measured
 Suspect Parameter Number: 1001
 Parameter Group Number: [65209]

spn1002 - Trip PTO Moving Fuel Used - Total fuel consumed while the PTO or remote PTO is in the hold state, the engine speed is greater than zero, and vehicle speed is greater than or equal to 2 km/h, since the last trip reset. NOTE: This parameter is intended for liquid fueled engines. See SPN 1008 for alternate resolution.

Data Length: 4 bytes
 Resolution: 0.5 L/bit , 0 offset
 Data Range: 0 to 2,105,540,607.5 L
 Type: Measured
 Suspect Parameter Number: 1002
 Parameter Group Number: [65209]

spn1003 - Trip PTO Non-moving Fuel Used - Total fuel consumed while the PTO or remote PTO is in the hold state, the engine speed is greater than zero, and vehicle speed is less than 2 km/h, since the last trip reset. NOTE: This parameter is intended for liquid fueled engines. See SPN 1009 for alternate resolution.

Data Length: 4 bytes
 Resolution: 0.5 L/bit , 0 offset
 Data Range: 0 to 2,105,540,607.5 L
 Type: Measured

Suspect Parameter Number: 1003
 Parameter Group Number: [65209]

spn1004 - Trip Vehicle Idle Fuel Used - Total fuel consumed while neither the PTO or remote PTO is in the hold state, the engine speed is greater than zero, and vehicle speed is less than 2 km/h, since the last trip reset. In marine applications, this parameter is defined as the total fuel consumed while the engine speed is greater than zero, and less than or equal to 50 RPM greater than low idle, since the last trip reset. NOTE: This parameter is intended for liquid fueled engines. See SPN 1010 for alternate resolution.

Data Length: 4 bytes
 Resolution: 0.5 L/bit , 0 offset
 Data Range: 0 to 2,105,540,607.5 L
 Type: Measured
 Suspect Parameter Number: 1004
 Parameter Group Number: [65209]

spn1005 - Trip Cruise Fuel Used - Total fuel consumed while the engine is in the cruise hold state since the last trip reset. If both cruise control and VSL (vehicle speed limiter) are commanding the same amount of fuel, the cruise control is deemed the active torque mode and fuel will be accumulated in "trip cruise fuel used" parameter. If fuel commanded due to the accelerator pedal position is larger than fuel commanded by cruise control (e.g., accelerator override torque mode), the cruise control is not deemed the active torque mode and fuel will not be accumulated in the "trip cruise fuel used" parameter. NOTE: This parameter is intended for liquid fueled engines. See SPN 1011 for alternate resolution.

Data Length: 4 bytes
 Resolution: 0.5 L/bit , 0 offset
 Data Range: 0 to 2,105,540,607.5 L
 Type: Measured
 Suspect Parameter Number: 1005
 Parameter Group Number: [65209]

spn1006 - Trip Drive Fuel Economy - Trip drive fuel economy is equal to the distance traveled by vehicle in the drive state (engine speed greater than zero, vehicle speed greater than or equal to 2 km/h, and neither the PTO or remote PTO is controlling engine power output) divided by trip drive fuel used (SPN 1001), since the last trip reset. NOTE: This parameter is intended for liquid fueled engines. See SPN 1012 for alternate resolution.

Data Length: 2 bytes
 Resolution: 1/512 km/L per bit , 0 offset
 Data Range: 0 to 125.5 km/L
 Type: Measured
 Suspect Parameter Number: 1006
 Parameter Group Number: [65209]

spn1007 - Trip Drive Fuel Used (Gaseous) - Total fuel consumed while the engine speed is greater than zero, vehicle speed is greater than or equal to 2 km/h, and neither the PTO or the remote PTO is controlling the engine power output, since the last trip reset. NOTE: This parameter is intended for gaseous fueled engines. See SPN 1001 for alternate resolution.

Data Length: 4 bytes
 Resolution: 0.5 kg/bit , 0 offset
 Data Range: 0 to 2,105,540,607.5 kg

Type: Measured
 Suspect Parameter Number: 1007
 Parameter Group Number: [65208]

spn1008 - Trip PTO Moving Fuel Used (Gaseous) - Total fuel consumed while the PTO or remote PTO is in the hold state, the engine speed is greater than zero, and vehicle speed is greater than or equal to 2 km/h, since the last trip reset. NOTE: This parameter is intended for gaseous fueled engines. See SPN 1002 for alternate resolution.

Data Length: 4 bytes
 Resolution: 0.5 kg/bit , 0 offset
 Data Range: 0 to 2,105,540,607.5 kg
 Type: Measured
 Suspect Parameter Number: 1008
 Parameter Group Number: [65208]

spn1009 - Trip PTO Non-moving Fuel Used (Gaseous) - Total fuel consumed while the PTO or remote PTO is in the hold state, the engine speed is greater than zero, and vehicle speed is less than to 2 km/h, since the last trip reset. NOTE: This parameter is intended for gaseous fueled engines. See SPN 1003 for alternate resolution.

Data Length: 4 bytes
 Resolution: 0.5 kg/bit , 0 offset
 Data Range: 0 to 2,105,540,607.5 kg
 Type: Measured
 Suspect Parameter Number: 1009
 Parameter Group Number: [65208]

spn1010 - Trip Vehicle Idle Fuel Used (Gaseous) - Total fuel consumed while neither the PTO or remote PTO is active, the engine speed is greater than zero, and vehicle speed is less than to 2 km/h, since the last trip reset. NOTE: This parameter is intended for gaseous fueled engines. See SPN 1004 for alternate resolution. Trip vehicle idle fuel while in fast idle (vehicle speed less than 2 km/h with engine speed greater than 700 rpm) shall be accumulated in the trip vehicle idle fuel category. All other fuel usage scenarios that do not fall directly in the categories defined shall be accumulated in trip drive fuel used.

Data Length: 4 bytes
 Resolution: 0.5 kg/bit , 0 offset
 Data Range: 0 to 2,105,540,607.5 kg
 Type: Measured
 Suspect Parameter Number: 1010
 Parameter Group Number: [65208]

spn1011 - Trip Cruise Fuel Used (Gaseous) - Total fuel consumed while the engine is in the cruise hold state since the last trip reset. If both cruise control and VSL (vehicle speed limiter) are commanding the same amount of fuel, the cruise control is deemed the active torque mode and fuel will be accumulated in "trip cruise fuel used" parameter. If fuel commanded due to the accelerator pedal position is larger than fuel commanded by cruise control (e.g., accelerator override torque mode), the cruise control is not deemed the active torque mode and fuel will not be accumulated in the "trip cruise fuel used" parameter. NOTE: This parameter is intended for gaseous fueled engines. See SPN 1005 for alternate resolution.

Data Length: 4 bytes
 Resolution: 0.5 kg/bit , 0 offset
 Data Range: 0 to 2,105,540,607.5 kg

Type: Measured
 Suspect Parameter Number: 1011
 Parameter Group Number: [65208]

spn1012 - Trip Drive Fuel Economy (Gaseous) - Trip drive fuel economy is equal to the distance traveled by vehicle in the drive state (engine speed greater than zero, vehicle speed greater than or equal to 2 km/h, and neither the PTO or remote PTO is controlling engine power output) divided by trip drive fuel used (SPN 1007), since the last trip reset. NOTE: This parameter is intended for gaseous fueled engines. See SPN 1006 for alternate resolution.

Data Length: 2 bytes
 Resolution: 1/512 km/kg per bit , 0 offset
 Data Range: 0 to 125.5 km/kg
 Type: Measured
 Suspect Parameter Number: 1012
 Parameter Group Number: [65208]

spn1013 - Trip Maximum Engine Speed - Maximum engine speed achieved since the last trip reset.

Data Length: 2 bytes
 Resolution: 0.125 rpm/bit , 0 offset
 Data Range: 0 to 8,031.875 rpm
 Type: Measured
 Suspect Parameter Number: 1013
 Parameter Group Number: [65207]

spn1014 - Trip Average Engine Speed - Average speed of the engine since the last trip reset. NOTE: Excludes ignition-on time without the engine speed above zero. Includes idle, PTO (moving and non-moving), and drive operation.

Data Length: 2 bytes
 Resolution: 0.125 rpm/bit , 0 offset
 Data Range: 0 to 8,031.875 rpm
 Type: Measured
 Suspect Parameter Number: 1014
 Parameter Group Number: [65207]

The equation is as follows:

$$\text{Trip average engine speed} = \frac{\sum_{i=0}^N \text{RPM}(i)}{N} \quad (\text{Eq.SP}1014_A)$$

where:

RPM is the engine speed at sample i, N is the number of samples of engine speed and is proportional to the current trip elapsed time

EQ SPN1014_A

spn1015 - Trip Drive Average Load Factor - Average engine load factor while engine speed is greater than zero, vehicle speed is greater than or equal to 2 km/h, and both the PTO (moving/non-moving) and remote PTO are not in the hold state, since the last trip reset. Engine operation during cruise control operation is included. In marine applications, this parameter is defined as

the average engine load factor while engine speed is greater than zero, since last trip reset.

Data Length: 1 byte
 Resolution: 0.4 %/bit , 0 offset
 Data Range: 0 to 100 %
 Type: Measured
 Suspect Parameter Number: 1015
 Parameter Group Number: [65207]

spn1016 - Total Drive Average Load Factor - Average engine load factor while engine speed is greater than zero, vehicle speed is greater than or equal to 2 km/h, and both the PTO (moving/non-moving) and remote PTO are not in the hold state, over the life of the engine. Engine operation during cruise control operation is included. In marine applications, this parameter is defined as the average engine load factor while engine speed is greater than zero.

Data Length: 1 byte
 Resolution: 0.4 %/bit , 0 offset
 Data Range: 0 to 100 %
 Type: Measured
 Suspect Parameter Number: 1016
 Parameter Group Number: [65207]

spn1017 - Total Engine Cruise Time - Total time that the engine has operated in the cruise hold state, excluding time in accelerator override, over the life of the engine.

Data Length: 4 bytes
 Resolution: 0.05 hr/bit , 0 offset
 Data Range: 0 to 210,554,060.75 hr
 Type: Measured
 Suspect Parameter Number: 1017
 Parameter Group Number: [65207]

spn1018 - Trip Maximum Vehicle Speed - Maximum vehicle speed achieved while the engine speed is greater than zero and the accelerator pedal position (APS) is at a value greater than 0%, since the last trip reset.

Data Length: 2 bytes
 Resolution: 1/256 km/h per bit , 0 offset
 Data Range: 0 to 250.996 km/h
 Type: Measured
 Suspect Parameter Number: 1018
 Parameter Group Number: [65206]

spn1019 - Trip Cruise Distance - Total distance that the engine has operated in the cruise hold state, excluding time in accelerator override, since the last trip reset.

Data Length: 4 bytes
 Resolution: 0.125 km/bit , 0 offset
 Data Range: 0 to 526,385,151.9 km
 Type: Measured
 Suspect Parameter Number: 1019

Parameter Group Number: [65206]

spn1020 - Trip Number of Hot Shutdowns - Total number of hot shutdowns since the last trip reset. A hot shutdown is based on operation at high load or high engine speed or for long operating periods without allowing the engine to cool sufficiently.

Data Length: 2 bytes
 Resolution: 1 count/bit , 0 offset
 Data Range: 0 to 64,255 counts
 Type: Measured
 Suspect Parameter Number: 1020
 Parameter Group Number: [65205]

spn1021 - Trip Number of Idle Shutdowns - Total number of times the engine has been shutdown due to idling too long (at normal idle or fast idle) since the last trip reset.

Data Length: 2 bytes
 Resolution: 1 count/bit , 0 offset
 Data Range: 0 to 64,255 counts
 Type: Measured
 Suspect Parameter Number: 1021
 Parameter Group Number: [65205]

spn1022 - Trip Number of Idle Shutdown Overrides - Total number of times an operator disables idle shutdown to prevent an engine shutdown, since the last trip reset.

Data Length: 2 bytes
 Resolution: 1 count/bit , 0 offset
 Data Range: 0 to 64,255 counts
 Type: Measured
 Suspect Parameter Number: 1022
 Parameter Group Number: [65205]

spn1023 - Trip Sudden Decelerations - Total number of decelerations whenever the vehicle deceleration is more than XYZ km/h/sec (where XYZ is a calibratable threshold), since the last trip reset. A lengthy deceleration shall be counted as one sudden deceleration.

Data Length: 2 bytes
 Resolution: 1 count/bit , 0 offset
 Data Range: 0 to 64,255 counts
 Type: Measured
 Suspect Parameter Number: 1023
 Parameter Group Number: [65205]

spn1024 - Trip Time in VSL - Total time accumulated when the engine has operated on the vehicle speed limiter (VSL) while not in the cruise hold state, since the last trip reset. The engine torque mode is equal to road speed governor during this operation.

Data Length: 4 bytes
 Resolution: 0.05 hr/bit , 0 offset
 Data Range: 0 to 210,554,060.75 hr

Type: Measured
 Suspect Parameter Number: 1024
 Parameter Group Number: [65204]

spn1025 - Trip Time in Top Gear - Total time accumulated when the vehicle has operated in top gear for a calibrated minimum time, since the last trip reset.

Data Length: 4 bytes
 Resolution: 0.05 hr/bit , 0 offset
 Data Range: 0 to 210,554,060.75 hr
 Type: Measured
 Suspect Parameter Number: 1025
 Parameter Group Number: [65204]

spn1026 - Trip Time in Gear Down - Total time accumulated when the vehicle has operated in one gear down from the top gear for a calibrated minimum time, since the last trip reset.

Data Length: 4 bytes
 Resolution: 0.05 hr/bit , 0 offset
 Data Range: 0 to 210,554,060.75 hr
 Type: Measured
 Suspect Parameter Number: 1026
 Parameter Group Number: [65204]

spn1027 - Trip Time in Derate by Engine - Total time accumulated when the engine final fueling has been derated due to an engine protection algorithm, since the last reset.

Data Length: 4 bytes
 Resolution: 0.05 hr/bit , 0 offset
 Data Range: 0 to 210,554,060.75 hr
 Type: Measured
 Suspect Parameter Number: 1027
 Parameter Group Number: [65204]

spn1028 - Total Engine PTO Fuel Used - Total fuel used while the PTO or remote PTO is in the hold state and engine speed is above zero, over the life of the engine. NOTE: This parameter is intended for liquid fueled engines. See SPN 1030 for alternate resolution.

Data Length: 4 bytes
 Resolution: 0.5 L/bit , 0 offset
 Data Range: 0 to 2,105,540,607.5 L
 Type: Measured
 Suspect Parameter Number: 1028
 Parameter Group Number: [65203]

spn1029 - Trip Average Fuel Rate - Average fuel rate, equal to trip fuel divided by trip time while the engine speed is above zero, since the last trip reset. This includes idle, PTO (both moving and non-moving) and drive operation but excludes ignition-on time while the engine speed is at zero rpm. NOTE: This parameter is intended for liquid fueled engines. See SPN 1031 for

alternate resolution.

Data Length:	2 bytes
Resolution:	0.05 L/h per bit , 0 offset
Data Range:	0 to 3,212.75 L/h
Type:	Measured
Suspect Parameter Number:	1029
Parameter Group Number:	[65203]

spn1030 - Total Engine PTO Fuel Used (Gaseous) - Total fuel used while the PTO or remote PTO is in the hold state and engine speed is above zero, over the life of the engine. NOTE: This parameter is intended for gaseous fueled engines. See SPN 1028 for alternate resolution.

Data Length:	4 bytes
Resolution:	0.5 kg/bit , 0 offset
Data Range:	0 to 2,105,540,607.5 kg
Type:	Measured
Suspect Parameter Number:	1030
Parameter Group Number:	[65202]

spn1031 - Trip Average Fuel Rate (Gaseous) - Average fuel rate, equal to trip fuel divided by trip time while the engine speed is above zero, since the last trip reset. This includes idle, PTO (both moving and non-moving) and drive operation but excludes ignition-on time while the engine speed is at zero rpm. NOTE: This parameter is intended for gaseous fueled engines. See SPN 1029 for alternate resolution.

Data Length:	2 bytes
Resolution:	0.05 kg/h per bit , 0 offset
Data Range:	0 to 3212.75 kg/h
Type:	Measured
Suspect Parameter Number:	1031
Parameter Group Number:	[65202]

spn1032 - Total ECU Distance - Total distance accumulated over the life of the ECU. When the ECU is replaced this value shall be reset.

Data Length:	4 bytes
Resolution:	0.125 km/bit , 0 offset
Data Range:	0 to 526,385,151.9 km
Type:	Measured
Suspect Parameter Number:	1032
Parameter Group Number:	[65201]

spn1033 - Total ECU Run Time - Total time accumulated over the life of the ECU, from ignition switch ON to ignition switch OFF. When the ECU is replaced this value shall be reset.

Data Length:	4 bytes
Resolution:	0.05 hr/bit , 0 offset
Data Range:	0 to 210,554,060.75 hr
Type:	Measured

Suspect Parameter Number: 1033
 Parameter Group Number: [65201]

spn1034 - Trip Cruise Time - Total time accumulated while the engine is in the cruise hold state, excluding time in accelerator override, since the last trip reset.

Data Length: 4 bytes
 Resolution: 0.05 hr/bit , 0 offset
 Data Range: 0 to 210,554,060.75 hr
 Type: Measured
 Suspect Parameter Number: 1034
 Parameter Group Number: [65200]

spn1035 - Trip PTO Time - Total time accumulated while the engine is in the PTO or remote PTO hold state since the last trip reset.

Data Length: 4 bytes
 Resolution: 0.05 hr/bit , 0 offset
 Data Range: 0 to 210,554,060.75 hr
 Type: Measured
 Suspect Parameter Number: 1035
 Parameter Group Number: [65200]

spn1036 - Trip Engine Running Time - Total time accumulated while the engine speed is greater than zero since the last trip reset. Note that time with the ignition switch on but engine speed at zero is not included.

Data Length: 4 bytes
 Resolution: 0.05 hr/bit , 0 offset
 Data Range: 0 to 210,554,060.75 hr
 Type: Measured
 Suspect Parameter Number: 1036
 Parameter Group Number: [65200]

spn1037 - Trip Idle Time - Total time accumulated while the engine speed is greater than zero, both the PTO and remote PTO is inactive, and the vehicle speed is less than 2 km/h, since the last trip reset. In marine applications, this parameter is defined as the total time accumulated while the engine speed is greater than zero, and less than or equal to 50 RPM greater than low idle, since the last trip reset.

Data Length: 4 bytes
 Resolution: 0.05 hr/bit , 0 offset
 Data Range: 0 to 210,554,060.75 hr
 Type: Measured
 Suspect Parameter Number: 1037
 Parameter Group Number: [65200]

spn1038 - Trip Air Compressor On Time - Total time that the air compressor is on and compressing air since the last trip reset.

Data Length: 4 bytes

Resolution: 0.05 hr/bit , 0 offset
 Data Range: 0 to 210,554,060.75 hr
 Type: Measured
 Suspect Parameter Number: 1038
 Parameter Group Number: [65200]

spn1039 - Trip Fuel (Gaseous) - Total fuel consumed (trip drive fuel + trip PTO moving fuel + trip PTO non-moving fuel + trip idle fuel) since the last trip reset.

Data Length: 4 bytes
 Resolution: 0.5 kg/bit , 0 offset
 Data Range: 0 to 2,105,540,607.5 kg
 Type: Measured
 Suspect Parameter Number: 1039
 Parameter Group Number: [65199]

spn1040 - Total Fuel Used (Gaseous) - Total fuel consumed (trip drive fuel + trip PTO moving fuel + trip PTO non-moving fuel + trip idle fuel) over the life of the engine.

Data Length: 4 bytes
 Resolution: 0.5 kg/bit , 0 offset
 Data Range: 0 to 2,105,540,607.5 kg
 Type: Measured
 Suspect Parameter Number: 1040
 Parameter Group Number: [65199]

spn1081 - Wait to Start Lamp - Lamp signal which indicates that the engine is too cold to start and the operator should wait until the signal becomes inactive (turns off).

00 - Off
 01 - On

Bit Length: 2 bits
 Type: Status
 Suspect Parameter Number: 1081
 Parameter Group Number: [65252]

spn1082 - Engine Coolant Load Increase - Status of an event, external to the engine, that may increase the nominal temperature of the engine coolant liquid.

00 No coolant load increase
 01 Coolant load increase possible

Bit Length: 2 bits
 Type: Status
 Suspect Parameter Number: 1082
 Parameter Group Number: [61440]

spn1083 - Auxiliary I/O Channel #1 - Auxiliary channel of data (16 bit) read by the ECU. This data is in A/D counts and is manufacturer specific. It may be configured uniquely per application.

Data Length: 2 bytes
 Resolution: 1 count/bit , 0 offset

Data Range: 0 to 64,255 counts
 Type: Measured
 Suspect Parameter Number: 1083
 Parameter Group Number: [65241]

spn1084 - Auxiliary I/O Channel #2 - Auxiliary channel of data (16 bit) read by the ECU. This data is in A/D counts and is manufacturer specific. It may be configured uniquely per application.

Data Length: 2 bytes
 Resolution: 1 count/bit , 0 offset
 Data Range: 0 to 64,255 counts
 Type: Measured
 Suspect Parameter Number: 1084
 Parameter Group Number: [65241]

spn1085 - Intended Retarder Percent Torque - Braking torque of retarder that the retarder is currently trying to achieve. This value takes into account all static limitations, but not the limitations due to the dynamic behavior of the retarder. This value, if unchanged over a certain time, can and will be reached by the actual retarder - percent torque (See SPN 520).

Data Length: 1 byte
 Resolution: 1 %/bit , -125% offset
 Data Range: -125 to 125 %
 Operating Range: -125 to 0%
 Type: Status
 Suspect Parameter Number: 1085
 Parameter Group Number: [61440]

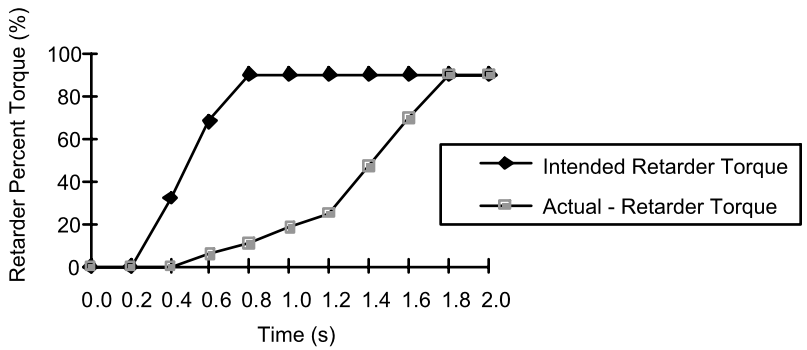

FIGURE SPN1085_A -- INTENDED RETARDER PERCENT TORQUE

spn1086 - Parking and/or Trailer Air Pressure - The pneumatic pressure in the circuit or reservoir for the parking brake and/or the trailer supply.

Data Length: 1 byte
 Resolution: 8 kPa/bit , 0 offset
 Data Range: 0 to 2,000 kPa
 Type: Measured
 Suspect Parameter Number: 1086
 Parameter Group Number: [65198]

spn1087 - Service Brake Air Pressure Circuit #1 - The pneumatic pressure in the service brake circuit or reservoir #1.

Data Length: 1 byte
 Resolution: 8 kPa/bit , 0 offset
 Data Range: 0 to 2,000 kPa
 Type: Measured
 Suspect Parameter Number: 1087
 Parameter Group Number: [65198]

spn1088 - Service Brake Air Pressure Circuit #2 - The pneumatic pressure in the service brake circuit or reservoir #2.

Data Length: 1 byte
 Resolution: 8 kPa/bit , 0 offset
 Data Range: 0 to 2,000 kPa
 Type: Measured
 Suspect Parameter Number: 1088
 Parameter Group Number: [65198]

spn1089 - Auxiliary Equipment Supply Pressure - The pneumatic pressure in the auxiliary circuit.

Data Length: 1 byte
 Resolution: 8 kPa/bit , 0 offset
 Data Range: 0 to 2,000 kPa
 Type: Measured
 Suspect Parameter Number: 1089
 Parameter Group Number: [65198]

spn1090 - Air Suspension Supply Pressure - The pneumatic pressure in the circuit for the electronically controlled air suspension system.

Data Length: 1 byte
 Resolution: 8 kPa/bit , 0 offset
 Data Range: 0 to 2,000 kPa
 Type: Measured
 Suspect Parameter Number: 1090
 Parameter Group Number: [65198]

spn1091 - Brake Application Pressure High Range, Front Axle, Left Wheel - The brake application pressure for the left wheel on the front axle.

Data Length: 1 byte
 Resolution: 5 kPa/bit , 0 offset
 Data Range: 0 to 1,250 kPa
 Type: Measured
 Suspect Parameter Number: 1091
 Parameter Group Number: [65197]

spn1092 - Brake Application Pressure High Range, Front Axle, Right Wheel - The brake application pressure for the right wheel on the front axle.

Data Length: 1 byte
 Resolution: 5 kPa/bit , 0 offset
 Data Range: 0 to 1,250 kPa
 Type: Measured
 Suspect Parameter Number: 1092
 Parameter Group Number: [65197]

spn1093 - Brake Application Pressure High Range, Rear Axle #1, Left Wheel - The brake application pressure for the left wheel on the rear axle #1.

Data Length: 1 byte
 Resolution: 5 kPa/bit , 0 offset
 Data Range: 0 to 1,250 kPa
 Type: Measured
 Suspect Parameter Number: 1093
 Parameter Group Number: [65197]

spn1094 - Brake Application Pressure High Range, Rear Axle #1, Right Wheel - The brake application pressure for the right wheel on the rear axle #1.

Data Length: 1 byte
 Resolution: 5 kPa/bit , 0 offset
 Data Range: 0 to 1,250 kPa
 Type: Measured
 Suspect Parameter Number: 1094
 Parameter Group Number: [65197]

spn1095 - Brake Application Pressure High Range, Rear Axle #2, Left Wheel - The brake application pressure for the left wheel on the rear axle #2.

Data Length: 1 byte
 Resolution: 5 kPa/bit , 0 offset
 Data Range: 0 to 1,250 kPa
 Type: Measured
 Suspect Parameter Number: 1095
 Parameter Group Number: [65197]

spn1096 - Brake Application Pressure High Range, Rear Axle #2, Right Wheel - The brake application pressure for the right wheel on the rear axle #2.

Data Length: 1 byte
 Resolution: 5 kPa/bit , 0 offset
 Data Range: 0 to 1,250 kPa
 Type: Measured
 Suspect Parameter Number: 1096
 Parameter Group Number: [65197]

spn1097 - Brake Application Pressure High Range, Rear Axle #3, Left Wheel - The brake application

pressure for the left wheel on the rear axle #3.

Data Length: 1 byte
 Resolution: 5 kPa/bit , 0 offset
 Data Range: 0 to 1,250 kPa
 Type: Measured
 Suspect Parameter Number: 1097
 Parameter Group Number: [65197]

spn1098 - Brake Application Pressure High Range, Rear Axle #3, Right Wheel - The brake application

pressure for the right wheel on the rear axle #3.

Data Length: 1 byte
 Resolution: 5 kPa/bit , 0 offset
 Data Range: 0 to 1,250 kPa
 Type: Measured
 Suspect Parameter Number: 1098
 Parameter Group Number: [65197]

spn1099 - Brake Lining Remaining, Front Axle, Left Wheel - The percentage of brake lining which can still be measured for the left wheel on the front axle. 100% represents new brake linings, 0% represents totally worn brake linings.

Data Length: 1 byte
 Resolution: 0.4 %/bit , 0 offset
 Data Range: 0 to 100 %
 Type: Measured
 Suspect Parameter Number: 1099
 Parameter Group Number: [65196]

spn1100 - Brake Lining Remaining, Front Axle, Right Wheel - The percentage of brake lining which can still be measured for the right wheel on the front axle. 100% represents new brake linings, 0% represents totally worn brake linings.

Data Length: 1 byte
 Resolution: 0.4 %/bit , 0 offset
 Data Range: 0 to 100 %
 Type: Measured
 Suspect Parameter Number: 1100
 Parameter Group Number: [65196]

spn1101 - Brake Lining Remaining, Rear Axle #1, Left Wheel - The percentage of brake lining which can still be measured for the left wheel on the rear axle #1. 100% represents new brake linings, 0% represents totally worn brake linings.

Data Length: 1 byte
 Resolution: 0.4 %/bit , 0 offset
 Data Range: 0 to 100 %
 Type: Measured
 Suspect Parameter Number: 1101
 Parameter Group Number: [65196]

spn1102 - Brake Lining Remaining, Rear Axle #1, Right Wheel - The percentage of brake lining which can still be measured for the right wheel on the rear axle #1. 100% represents new brake linings, 0% represents totally worn brake linings.

Data Length: 1 byte
 Resolution: 0.4 %/bit , 0 offset
 Data Range: 0 to 100 %
 Type: Measured
 Suspect Parameter Number: 1102
 Parameter Group Number: [65196]

spn1103 - Brake Lining Remaining, Rear Axle #2, Left Wheel - The percentage of brake lining which can still be measured for the left wheel on the rear axle #2. 100% represents new brake linings, 0% represents totally worn brake linings.

Data Length: 1 byte
 Resolution: 0.4 %/bit , 0 offset
 Data Range: 0 to 100 %
 Type: Measured
 Suspect Parameter Number: 1103
 Parameter Group Number: [65196]

spn1104 - Brake Lining Remaining, Rear Axle #2, Right Wheel - The percentage of brake lining which can still be measured for the right wheel on the rear axle #2. 100% represents new brake linings, 0% represents totally worn brake linings.

Data Length: 1 byte
 Resolution: 0.4 %/bit , 0 offset
 Data Range: 0 to 100 %
 Type: Measured
 Suspect Parameter Number: 1104
 Parameter Group Number: [65196]

spn1105 - Brake Lining Remaining, Rear Axle #3, Left Wheel - The percentage of brake lining which can still be measured for the left wheel on the rear axle #3. 100% represents new brake linings, 0% represents totally worn brake linings.

Data Length: 1 byte
 Resolution: 0.4 %/bit , 0 offset
 Data Range: 0 to 100 %
 Type: Measured
 Suspect Parameter Number: 1105
 Parameter Group Number: [65196]

spn1106 - Brake Lining Remaining, Rear Axle #3, Right Wheel - The percentage of brake lining which can still be measured for the right wheel on the rear axle #3. 100% represents new brake linings, 0% represents totally worn brake linings.

Data Length: 1 byte
 Resolution: 0.4 %/bit , 0 offset
 Data Range: 0 to 100 %
 Type: Measured
 Suspect Parameter Number: 1106
 Parameter Group Number: [65196]

spn1107 - Engine Protection System Timer State - Status signal which indicates the current mode of the engine protection system timer system. See Figure SPN1107_A.

- 00 - Inactive
- 01 - Active

Bit Length: 2 bits
 Type: Status
 Suspect Parameter Number: 1107
 Parameter Group Number: [65252]

Engine Protection System (EPS)

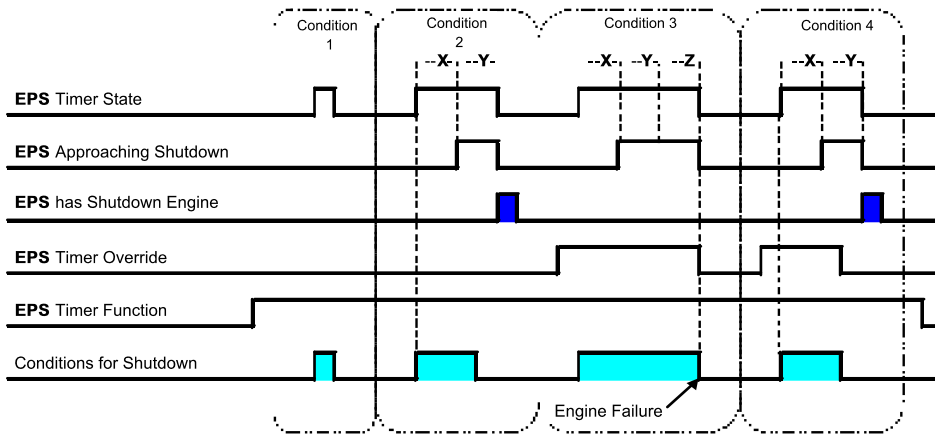

Condition 1– When the EPS Timer Override is inactive, the EPS Timer State will become inactive if the conditions for shutdown no longer exist before the "X" time interval has expired or EPS Approaching Shutdown is activated.

Condition 2– When the EPS Timer Override is inactive and conditions for shutdown exist during the "Y" time interval, then the Engine will shutdown, even though shutdown conditions subside before the "Y" time interval has expired.

Condition 3– When the EPS Timer Override is active, then the EPS feature shall be overridden allowing for an engine failure when the "Z" time interval has expired.

Condition 4– When the EPS Timer Override is active and then allowed to go inactive during the "Y" time interval, the response by the EPS shall be the same as condition 2. The time intervals for "X" and "Y" shall always start when conditions for shutdown first commence regardless whether the EPS Timer Override is enabled or not.

NOTE — 0 State– Inactive, disabled in calibration, or conditions for Engine Protection do not exist.
 1 State– Active, enabled in calibration, or conditions for Engine Protection do exist.

FIGURE SPN1107_A -- ENGINE PROTECTION SYSTEM (EPS)

spn1108 - Engine Protection System Timer Override - Status signal which indicates the status of the override feature of the engine protection system timer. See Figure SPN1107_A.

- 00 - Inactive
- 01 - Active

Bit Length: 2 bits
 Type: Status
 Suspect Parameter Number: 1108

Parameter Group Number: [65252]

spn1109 - Engine Protection System Approaching Shutdown - Status signal which indicates that engine shutdown is imminent. This engine protection signal can be a result of different systems failing, i.e., engine overheating. See Figure SPN1107_A.

00 - Not approaching
01 - Approaching

Bit Length: 2 bits
Type: Status
Suspect Parameter Number: 1109
Parameter Group Number: [65252]

spn1110 - Engine Protection System has Shutdown Engine - Status signal which indicates whether or not the engine protection system has shutdown the engine. See Figure SPN1107_A.

00 - No
01 - Yes

Bit Length: 2 bits
Type: Status
Suspect Parameter Number: 1110
Parameter Group Number: [65252]

spn1111 - Engine Protection System Configuration - Parameter which indicates the configuration of the engine shutdown system.

00 - Disabled in calibration
01 - Enabled in calibration

Bit Length: 2 bits
Type: Status
Suspect Parameter Number: 1111
Parameter Group Number: [65252]

spn1113 - Recommended Gear - The transmission calculates this gear continuously. In dangerous situations this gear may be selected to gain back vehicle control.

Data Length: 1 byte
Resolution: 1 gear value/bit , -125 offset
Data Range: -125 to 125
Operating Range: -125 to +125, negative values are reverse gears, positive values are forward gears, zero is neutral. 251 (0xFB) is park.
Type: Status
Suspect Parameter Number: 1113
Parameter Group Number: [65195]

spn1114 - Lowest Possible Gear - The transmission calculates this gear continuously. Together with the highest possible gear (see SPN 1115), it enables a management computer to know the exact range of available gears.

Data Length: 1 byte
Resolution: 1 gear value/bit , -125 offset
Data Range: -125 to 125
Operating Range: -125 to +125, negative values are reverse gears, positive values are forward gears, zero is neutral. 251 (0xFB) is park.

Type: Status
 Suspect Parameter Number: 1114
 Parameter Group Number: [65195]

spn1115 - Highest Possible Gear - The transmission calculates this gear continuously. Together with the lowest possible gear (see SPN 1114), it enables a management computer to know the exact range of available gears.

Data Length: 1 byte
 Resolution: 1 gear value/bit , -125 offset
 Data Range: -125 to 125
 Operating Range: -125 to +125, negative values are reverse gears, positive values are forward gears, zero is neutral. 251 (0xFB) is park.
 Type: Status
 Suspect Parameter Number: 1115
 Parameter Group Number: [65195]

spn1116 - Gaseous Fuel Correction Factor - A correction to a predefined gaseous fuel energy (expressed in energy per unit volume) represented as a percentage. The actual fuel energy used to control the engine is the product of the gaseous fuel correction factor and the energy of the gas.

Data Length: 1 byte
 Resolution: 1 %/bit , 0 offset
 Data Range: 0 to 250 %
 Type: Measured
 Suspect Parameter Number: 1116
 Parameter Group Number: [65194]

spn1117 - Desired Rated Exhaust Oxygen - The desired amount of oxygen in the exhaust at rated conditions represented as a percentage by volume with respect to the total volume of exhaust gases leaving the engine.

Data Length: 2 bytes
 Resolution: 0.0025 %/bit , 0 offset
 Data Range: 0 to 160.6375 %
 Type: Measured
 Suspect Parameter Number: 1117
 Parameter Group Number: [65193]

spn1118 - Desired Exhaust Oxygen - The desired amount of oxygen in the exhaust represented as a percentage by volume with respect to the total volume of exhaust gases leaving the engine.

Data Length: 2 bytes
 Resolution: 0.0025 %/bit , 0 offset
 Data Range: 0 to 160.6375 %
 Type: Measured
 Suspect Parameter Number: 1118
 Parameter Group Number: [65193]

spn1119 - Actual Exhaust Oxygen - The actual amount of oxygen in the exhaust represented as a percentage by volume with respect to the total volume of exhaust gases leaving the engine.

Data Length: 2 bytes
 Resolution: 0.0025 %/bit , 0 offset
 Data Range: 0 to 160.6375 %
 Type: Measured
 Suspect Parameter Number: 1119
 Parameter Group Number: [65193]

spn1120 - Articulation Angle - Angle of deflection of an articulated transit vehicle. A right turn is indicated with a positive angle and a left turn is indicated with a negative angle.

Data Length: 1 byte
 Resolution: 1 deg/bit , -125 deg offset
 Data Range: -125 to 125 deg
 Type: Measured
 Suspect Parameter Number: 1120
 Parameter Group Number: [65192]

spn1121 - EBS Brake Switch - Switch signal which indicates that the brake pedal is being pressed. The EBS brake switch is independent of the brake light switch and has no provisions for external connections.

00 Brake pedal is not being pressed
 01 Brake pedal is being pressed

Bit Length: 2 bits
 Type: Measured
 Suspect Parameter Number: 1121
 Parameter Group Number: [61441]

spn1122 - Alternator Bearing 1 Temperature - Temperature of the bearing inside the alternator. Bearing 1 is the left or rear bearing.

Data Length: 1 byte
 Resolution: 1 deg C/bit , -40 deg C offset
 Data Range: -40 to 210 deg C
 Type: Measured
 Suspect Parameter Number: 1122
 Parameter Group Number: [65191]

spn1123 - Alternator Bearing 2 Temperature - Temperature of the bearing inside the alternator. Bearing 2 is the right or front bearing.

Data Length: 1 byte
 Resolution: 1 deg C/bit , -40 deg C offset
 Data Range: -40 to 210 deg C
 Type: Measured
 Suspect Parameter Number: 1123
 Parameter Group Number: [65191]

spn1124 - Alternator Winding 1 Temperature - Temperature of the windings inside the alternator.

Data Length: 1 byte

Resolution: 1 deg C/bit , -40 deg C offset
 Data Range: -40 to 210 deg C
 Type: Measured
 Suspect Parameter Number: 1124
 Parameter Group Number: [65191]

spn1125 - Alternator Winding 2 Temperature - Temperature of the windings inside the alternator.

Data Length: 1 byte
 Resolution: 1 deg C/bit , -40 deg C offset
 Data Range: -40 to 210 deg C
 Type: Measured
 Suspect Parameter Number: 1125
 Parameter Group Number: [65191]

spn1126 - Alternator Winding 3 Temperature - Temperature of the windings inside the alternator.

Data Length: 1 byte
 Resolution: 1 deg C/bit , -40 deg C offset
 Data Range: -40 to 210 deg C
 Type: Measured
 Suspect Parameter Number: 1126
 Parameter Group Number: [65191]

spn1127 - Turbocharger 1 Boost Pressure - Gage pressure of air measured downstream of the compressor discharge side of the turbocharger. See also SPN 102 for alternate range and resolution. If there is only one boost pressure to report and the range and resolution in SPN 102 is adequate, then it should be used.

Data Length: 2 bytes
 Resolution: 0.125 kPa/bit , 0 offset
 Data Range: 0 to +8031.875 kPa (0 to 1164.62 psi)
 Type: Measured
 Suspect Parameter Number: 1127
 Parameter Group Number: [65190]

spn1128 - Turbocharger 2 Boost Pressure - Gage pressure of air measured downstream of the compressor discharge side of the turbocharger. See also SPN 102 for alternate range and resolution. If there is only one boost pressure to report and the range and resolution in SPN 102 is adequate, then it should be used.

Data Length: 2 bytes
 Resolution: 0.125 kPa/bit , 0 offset
 Data Range: 0 to +8031.875 kPa (0 to 1164.62 psi)
 Type: Measured
 Suspect Parameter Number: 1128
 Parameter Group Number: [65190]

spn1129 - Turbocharger 3 Boost Pressure - Gage pressure of air measured downstream of the compressor discharge side of the turbocharger. See also SPN 102 for alternate range and resolution. If there is only one boost pressure to report and the range

and resolution in SPN 102 is adequate, then it should be used.

Data Length: 2 bytes
 Resolution: 0.125 kPa/bit , 0 offset
 Data Range: 0 to +8031.875 kPa (0 to 1164.62 psi)
 Type: Measured
 Suspect Parameter Number: 1129
 Parameter Group Number: [65190]

spn1130 - Turbocharger 4 Boost Pressure - Gage pressure of air measured downstream of the compressor discharge side of the turbocharger. See also SPN 102 for alternate range and resolution. If there is only one boost pressure to report and the range and resolution in SPN 102 is adequate, then it should be used.

Data Length: 2 bytes
 Resolution: 0.125 kPa/bit , 0 offset
 Data Range: 0 to +8031.875 kPa (0 to 1164.62 psi)
 Type: Measured
 Suspect Parameter Number: 1130
 Parameter Group Number: [65190]

spn1131 - Intake Manifold 2 Temperature - Temperature of pre-combustion air found in intake manifold of engine air supply system.

Data Length: 1 byte
 Resolution: 1 deg C/bit , -40 deg C offset
 Data Range: -40 to 210 deg C
 Type: Measured
 Suspect Parameter Number: 1131
 Parameter Group Number: [65189]

spn1132 - Intake Manifold 3 Temperature - Temperature of pre-combustion air found in intake manifold of engine air supply system.

Data Length: 1 byte
 Resolution: 1 deg C/bit , -40 deg C offset
 Data Range: -40 to 210 deg C
 Type: Measured
 Suspect Parameter Number: 1132
 Parameter Group Number: [65189]

spn1133 - Intake Manifold 4 Temperature - Temperature of pre-combustion air found in intake manifold of engine air supply system.

Data Length: 1 byte
 Resolution: 1 deg C/bit , -40 deg C offset
 Data Range: -40 to 210 deg C
 Type: Measured
 Suspect Parameter Number: 1133
 Parameter Group Number: [65189]

spn1134 - Engine Intercooler Thermostat Opening - The current position of the thermostat used to regulate the temperature of the engine intercooler. A value of 0% represents the thermostat being completely closed and 100% represents the thermostat being completely open.

Data Length: 1 byte
 Resolution: 0.4 %/bit , 0 offset
 Data Range: 0 to 100 %
 Type: Measured
 Suspect Parameter Number: 1134
 Parameter Group Number: [65262]

spn1135 - Engine Oil Temperature 2 - Temperature of the engine lubricant.

Data Length: 2 bytes
 Resolution: 0.03125 deg C/bit , -273 deg C offset
 Data Range: -273 to 1735 deg C
 Type: Measured
 Suspect Parameter Number: 1135
 Parameter Group Number: [65188]

spn1136 - Engine ECU Temperature - Temperature of the engine electronic control unit.

Data Length: 2 bytes
 Resolution: 0.03125 deg C/bit , -273 deg C offset
 Data Range: -273 to 1735 deg C
 Type: Measured
 Suspect Parameter Number: 1136
 Parameter Group Number: [65188]

spn1137 - Exhaust Gas Port 1 Temperature - Temperature at the cylinder exhaust port of the engine.

Data Length: 2 bytes
 Resolution: 0.03125 deg C/bit , -273 deg C offset
 Data Range: -273 to 1735 deg C
 Type: Measured
 Suspect Parameter Number: 1137
 Parameter Group Number: [65187]

spn1138 - Exhaust Gas Port 2 Temperature - Temperature at the cylinder exhaust port of the engine.

Data Length: 2 bytes
 Resolution: 0.03125 deg C/bit , -273 deg C offset
 Data Range: -273 to 1735 deg C
 Type: Measured
 Suspect Parameter Number: 1138
 Parameter Group Number: [65187]

spn1139 - Exhaust Gas Port 3 Temperature - Temperature at the cylinder exhaust port of the engine.

Data Length: 2 bytes

Resolution: 0.03125 deg C/bit , -273 deg C offset
 Data Range: -273 to 1735 deg C
 Type: Measured
 Suspect Parameter Number: 1139
 Parameter Group Number: [65187]

spn1140 - Exhaust Gas Port 4 Temperature - Temperature at the cylinder exhaust port of the engine.

Data Length: 2 bytes
 Resolution: 0.03125 deg C/bit , -273 deg C offset
 Data Range: -273 to 1735 deg C
 Type: Measured
 Suspect Parameter Number: 1140
 Parameter Group Number: [65187]

spn1141 - Exhaust Gas Port 5 Temperature - Temperature at the cylinder exhaust port of the engine.

Data Length: 2 bytes
 Resolution: 0.03125 deg C/bit , -273 deg C offset
 Data Range: -273 to 1735 deg C
 Type: Measured
 Suspect Parameter Number: 1141
 Parameter Group Number: [65186]

spn1142 - Exhaust Gas Port 6 Temperature - Temperature at the cylinder exhaust port of the engine.

Data Length: 2 bytes
 Resolution: 0.03125 deg C/bit , -273 deg C offset
 Data Range: -273 to 1735 deg C
 Type: Measured
 Suspect Parameter Number: 1142
 Parameter Group Number: [65186]

spn1143 - Exhaust Gas Port 7 Temperature - Temperature at the cylinder exhaust port of the engine.

Data Length: 2 bytes
 Resolution: 0.03125 deg C/bit , -273 deg C offset
 Data Range: -273 to 1735 deg C
 Type: Measured
 Suspect Parameter Number: 1143
 Parameter Group Number: [65186]

spn1144 - Exhaust Gas Port 8 Temperature - Temperature at the cylinder exhaust port of the engine.

Data Length: 2 bytes
 Resolution: 0.03125 deg C/bit , -273 deg C offset
 Data Range: -273 to 1735 deg C
 Type: Measured
 Suspect Parameter Number: 1144

Parameter Group Number: [65186]

spn1145 - Exhaust Gas Port 9 Temperature - Temperature at the cylinder exhaust port of the engine.

Data Length: 2 bytes
 Resolution: 0.03125 deg C/bit , -273 deg C offset
 Data Range: -273 to 1735 deg C
 Type: Measured
 Suspect Parameter Number: 1145
 Parameter Group Number: [65185]

spn1146 - Exhaust Gas Port 10 Temperature - Temperature at the cylinder exhaust port of the engine.

Data Length: 2 bytes
 Resolution: 0.03125 deg C/bit , -273 deg C offset
 Data Range: -273 to 1735 deg C
 Type: Measured
 Suspect Parameter Number: 1146
 Parameter Group Number: [65185]

spn1147 - Exhaust Gas Port 11 Temperature - Temperature at the cylinder exhaust port of the engine.

Data Length: 2 bytes
 Resolution: 0.03125 deg C/bit , -273 deg C offset
 Data Range: -273 to 1735 deg C
 Type: Measured
 Suspect Parameter Number: 1147
 Parameter Group Number: [65185]

spn1148 - Exhaust Gas Port 12 Temperature - Temperature at the cylinder exhaust port of the engine.

Data Length: 2 bytes
 Resolution: 0.03125 deg C/bit , -273 deg C offset
 Data Range: -273 to 1735 deg C
 Type: Measured
 Suspect Parameter Number: 1148
 Parameter Group Number: [65185]

spn1149 - Exhaust Gas Port 13 Temperature - Temperature at the cylinder exhaust port of the engine.

Data Length: 2 bytes
 Resolution: 0.03125 deg C/bit , -273 deg C offset
 Data Range: -273 to 1735 deg C
 Type: Measured
 Suspect Parameter Number: 1149
 Parameter Group Number: [65184]

spn1150 - Exhaust Gas Port 14 Temperature - Temperature at the cylinder exhaust port of the engine.

Data Length: 2 bytes

Resolution: 0.03125 deg C/bit , -273 deg C offset
 Data Range: -273 to 1735 deg C
 Type: Measured
 Suspect Parameter Number: 1150
 Parameter Group Number: [65184]

spn1151 - Exhaust Gas Port 15 Temperature - Temperature at the cylinder exhaust port of the engine.

Data Length: 2 bytes
 Resolution: 0.03125 deg C/bit , -273 deg C offset
 Data Range: -273 to 1735 deg C
 Type: Measured
 Suspect Parameter Number: 1151
 Parameter Group Number: [65184]

spn1152 - Exhaust Gas Port 16 Temperature - Temperature at the cylinder exhaust port of the engine.

Data Length: 2 bytes
 Resolution: 0.03125 deg C/bit , -273 deg C offset
 Data Range: -273 to 1735 deg C
 Type: Measured
 Suspect Parameter Number: 1152
 Parameter Group Number: [65184]

spn1153 - Exhaust Gas Port 17 Temperature - Temperature at the cylinder exhaust port of the engine.

Data Length: 2 bytes
 Resolution: 0.03125 deg C/bit , -273 deg C offset
 Data Range: -273 to 1735 deg C
 Type: Measured
 Suspect Parameter Number: 1153
 Parameter Group Number: [65183]

spn1154 - Exhaust Gas Port 18 Temperature - Temperature at the cylinder exhaust port of the engine.

Data Length: 2 bytes
 Resolution: 0.03125 deg C/bit , -273 deg C offset
 Data Range: -273 to 1735 deg C
 Type: Measured
 Suspect Parameter Number: 1154
 Parameter Group Number: [65183]

spn1155 - Exhaust Gas Port 19 Temperature - Temperature at the cylinder exhaust port of the engine.

Data Length: 2 bytes
 Resolution: 0.03125 deg C/bit , -273 deg C offset
 Data Range: -273 to 1735 deg C
 Type: Measured
 Suspect Parameter Number: 1155

Parameter Group Number: [65183]

spn1156 - Exhaust Gas Port 20 Temperature - Temperature at the cylinder exhaust port of the engine.

Data Length: 2 bytes
 Resolution: 0.03125 deg C/bit , -273 deg C offset
 Data Range: -273 to 1735 deg C
 Type: Measured
 Suspect Parameter Number: 1156
 Parameter Group Number: [65183]

spn1157 - Main Bearing 1 Temperature - Temperature of the main bearing which supports the crankshaft of the engine.

Data Length: 2 bytes
 Resolution: 0.03125 deg C/bit , -273 deg C offset
 Data Range: -273 to 1735 deg C
 Type: Measured
 Suspect Parameter Number: 1157
 Parameter Group Number: [65182]

spn1158 - Main Bearing 2 Temperature - Temperature of the main bearing which supports the crankshaft of the engine.

Data Length: 2 bytes
 Resolution: 0.03125 deg C/bit , -273 deg C offset
 Data Range: -273 to 1735 deg C
 Type: Measured
 Suspect Parameter Number: 1158
 Parameter Group Number: [65182]

spn1159 - Main Bearing 3 Temperature - Temperature of the main bearing which supports the crankshaft of the engine.

Data Length: 2 bytes
 Resolution: 0.03125 deg C/bit , -273 deg C offset
 Data Range: -273 to 1735 deg C
 Type: Measured
 Suspect Parameter Number: 1159
 Parameter Group Number: [65182]

spn1160 - Main Bearing 4 Temperature - Temperature of the main bearing which supports the crankshaft of the engine.

Data Length: 2 bytes
 Resolution: 0.03125 deg C/bit , -273 deg C offset
 Data Range: -273 to 1735 deg C
 Type: Measured
 Suspect Parameter Number: 1160
 Parameter Group Number: [65182]

spn1161 - Main Bearing 5 Temperature - Temperature of the main bearing which supports the crankshaft of the engine.

Data Length: 2 bytes

Resolution: 0.03125 deg C/bit , -273 deg C offset
 Data Range: -273 to 1735 deg C
 Type: Measured
 Suspect Parameter Number: 1161
 Parameter Group Number: [65181]

spn1162 - Main Bearing 6 Temperature - Temperature of the main bearing which supports the crankshaft of the engine.

Data Length: 2 bytes
 Resolution: 0.03125 deg C/bit , -273 deg C offset
 Data Range: -273 to 1735 deg C
 Type: Measured
 Suspect Parameter Number: 1162
 Parameter Group Number: [65181]

spn1163 - Main Bearing 7 Temperature - Temperature of the main bearing which supports the crankshaft of the engine.

Data Length: 2 bytes
 Resolution: 0.03125 deg C/bit , -273 deg C offset
 Data Range: -273 to 1735 deg C
 Type: Measured
 Suspect Parameter Number: 1163
 Parameter Group Number: [65181]

spn1164 - Main Bearing 8 Temperature - Temperature of the main bearing which supports the crankshaft of the engine.

Data Length: 2 bytes
 Resolution: 0.03125 deg C/bit , -273 deg C offset
 Data Range: -273 to 1735 deg C
 Type: Measured
 Suspect Parameter Number: 1164
 Parameter Group Number: [65181]

spn1165 - Main Bearing 9 Temperature - Temperature of the main bearing which supports the crankshaft of the engine.

Data Length: 2 bytes
 Resolution: 0.03125 deg C/bit , -273 deg C offset
 Data Range: -273 to 1735 deg C
 Type: Measured
 Suspect Parameter Number: 1165
 Parameter Group Number: [65180]

spn1166 - Main Bearing 10 Temperature - Temperature of the main bearing which supports the crankshaft of the engine.

Data Length: 2 bytes
 Resolution: 0.03125 deg C/bit , -273 deg C offset
 Data Range: -273 to 1735 deg C
 Type: Measured

Suspect Parameter Number: 1166
 Parameter Group Number: [65180]

spn1167 - Main Bearing 11 Temperature - Temperature of the main bearing which supports the crankshaft of the engine.

Data Length: 2 bytes
 Resolution: 0.03125 deg C/bit , -273 deg C offset
 Data Range: -273 to 1735 deg C
 Type: Measured
 Suspect Parameter Number: 1167
 Parameter Group Number: [65180]

spn1168 - Turbocharger Lube Oil Pressure 2 - Gage pressure of oil in turbocharger lubrication system.

Data Length: 1 byte
 Resolution: 4 kPa/bit , 0 offset
 Data Range: 0 to 1000 kPa
 Type: Measured
 Suspect Parameter Number: 1168
 Parameter Group Number: [65179]

spn1169 - Turbocharger 2 Speed - Rotational velocity of rotor in the turbocharger.

Data Length: 2 bytes
 Resolution: 4 rpm/bit , 0 offset
 Data Range: 0 to 257,020 rpm
 Type: Measured
 Suspect Parameter Number: 1169
 Parameter Group Number: [65179]

spn1170 - Turbocharger 3 Speed - Rotational velocity of rotor in the turbocharger.

Data Length: 2 bytes
 Resolution: 4 rpm/bit , 0 offset
 Data Range: 0 to 257,020 rpm
 Type: Measured
 Suspect Parameter Number: 1170
 Parameter Group Number: [65179]

spn1171 - Turbocharger 4 Speed - Rotational velocity of rotor in the turbocharger.

Data Length: 2 bytes
 Resolution: 4 rpm/bit , 0 offset
 Data Range: 0 to 257,020 rpm
 Type: Measured
 Suspect Parameter Number: 1171
 Parameter Group Number: [65179]

spn1172 - Turbocharger 1 Compressor Inlet Temperature - Temperature of the air entering the compressor side of the turbocharger.

Data Length: 2 bytes
 Resolution: 0.03125 deg C/bit , -273 deg C offset
 Data Range: -273 to 1735 deg C
 Type: Measured
 Suspect Parameter Number: 1172
 Parameter Group Number: [65178]

spn1173 - Turbocharger 2 Compressor Inlet Temperature - Temperature of the air entering the compressor side of the turbocharger.

Data Length: 2 bytes
 Resolution: 0.03125 deg C/bit , -273 deg C offset
 Data Range: -273 to 1735 deg C
 Type: Measured
 Suspect Parameter Number: 1173
 Parameter Group Number: [65178]

spn1174 - Turbocharger 3 Compressor Inlet Temperature - Temperature of the air entering the compressor side of the turbocharger.

Data Length: 2 bytes
 Resolution: 0.03125 deg C/bit , -273 deg C offset
 Data Range: -273 to 1735 deg C
 Type: Measured
 Suspect Parameter Number: 1174
 Parameter Group Number: [65178]

spn1175 - Turbocharger 4 Compressor Inlet Temperature - Temperature of the air entering the compressor side of the turbocharger.

Data Length: 2 bytes
 Resolution: 0.03125 deg C/bit , -273 deg C offset
 Data Range: -273 to 1735 deg C
 Type: Measured
 Suspect Parameter Number: 1175
 Parameter Group Number: [65178]

spn1176 - Turbocharger 1 Compressor Inlet Pressure - Gage pressure of the air entering the compressor side of the turbocharger.

Data Length: 2 bytes
 Resolution: 1/128 kPa/bit , -250 kPa offset
 Data Range: -250 kPa TO 251.99 kPa
 Type: Measured
 Suspect Parameter Number: 1176
 Parameter Group Number: [65177]

spn1177 - Turbocharger 2 Compressor Inlet Pressure - Gage pressure of the air entering the compressor side of the turbocharger.

Data Length: 2 bytes
 Resolution: 1/128 kPa/bit , -250 kPa offset
 Data Range: -250 kPa TO 251.99 kPa
 Type: Measured
 Suspect Parameter Number: 1177
 Parameter Group Number: [65177]

spn1178 - Turbocharger 3 Compressor Inlet Pressure - Gage pressure of the air entering the compressor side of the turbocharger.

Data Length: 2 bytes
 Resolution: 1/128 kPa/bit , -250 kPa offset
 Data Range: -250 kPa TO 251.99 kPa
 Type: Measured
 Suspect Parameter Number: 1178
 Parameter Group Number: [65177]

spn1179 - Turbocharger 4 Compressor Inlet Pressure - Gage pressure of the air entering the compressor side of the turbocharger.

Data Length: 2 bytes
 Resolution: 1/128 kPa/bit , -250 kPa offset
 Data Range: -250 kPa TO 251.99 kPa
 Type: Measured
 Suspect Parameter Number: 1179
 Parameter Group Number: [65177]

spn1180 - Turbocharger 1 Turbine Inlet Temperature - Temperature of the combustion by-products entering the turbine side of the turbocharger.

Data Length: 2 bytes
 Resolution: 0.03125 deg C/bit , -273 deg C offset
 Data Range: -273 to 1735 deg C
 Type: Measured
 Suspect Parameter Number: 1180
 Parameter Group Number: [65176]

spn1181 - Turbocharger 2 Turbine Inlet Temperature - Temperature of the combustion by-products entering the turbine side of the turbocharger.

Data Length: 2 bytes
 Resolution: 0.03125 deg C/bit , -273 deg C offset
 Data Range: -273 to 1735 deg C
 Type: Measured
 Suspect Parameter Number: 1181
 Parameter Group Number: [65176]

spn1182 - Turbocharger 3 Turbine Inlet Temperature - Temperature of the combustion by-products entering the turbine side of the turbocharger.

Data Length: 2 bytes
 Resolution: 0.03125 deg C/bit , -273 deg C offset
 Data Range: -273 to 1735 deg C
 Type: Measured
 Suspect Parameter Number: 1182
 Parameter Group Number: [65176]

spn1183 - Turbocharger 4 Turbine Inlet Temperature - Temperature of the combustion by-products entering the turbine side of the turbocharger.

Data Length: 2 bytes
 Resolution: 0.03125 deg C/bit , -273 deg C offset
 Data Range: -273 to 1735 deg C
 Type: Measured
 Suspect Parameter Number: 1183
 Parameter Group Number: [65176]

spn1184 - Turbocharger 1 Turbine Outlet Temperature - Temperature of the combustion by-products exiting the turbine side of the turbocharger.

Data Length: 2 bytes
 Resolution: 0.03125 deg C/bit , -273 deg C offset
 Data Range: -273 to 1735 deg C
 Type: Measured
 Suspect Parameter Number: 1184
 Parameter Group Number: [65175]

spn1185 - Turbocharger 2 Turbine Outlet Temperature - Temperature of the combustion by-products exiting the turbine side of the turbocharger.

Data Length: 2 bytes
 Resolution: 0.03125 deg C/bit , -273 deg C offset
 Data Range: -273 to 1735 deg C
 Type: Measured
 Suspect Parameter Number: 1185
 Parameter Group Number: [65175]

spn1186 - Turbocharger 3 Turbine Outlet Temperature - Temperature of the combustion by-products exiting the turbine side of the turbocharger.

Data Length: 2 bytes
 Resolution: 0.03125 deg C/bit , -273 deg C offset
 Data Range: -273 to 1735 deg C
 Type: Measured
 Suspect Parameter Number: 1186
 Parameter Group Number: [65175]

spn1187 - Turbocharger 4 Turbine Outlet Temperature - Temperature of the combustion by-products exiting the turbine side of the turbocharger.

Data Length: 2 bytes
 Resolution: 0.03125 deg C/bit , -273 deg C offset
 Data Range: -273 to 1735 deg C
 Type: Measured
 Suspect Parameter Number: 1187
 Parameter Group Number: [65175]

spn1188 - Turbocharger 1 Wastegate Drive - Position of the wastegate drive. A value of 0% represents fully closed and a value of 100% represents fully open.

Data Length: 1 byte
 Resolution: 0.4 %/bit , 0 offset
 Data Range: 0 to 100 %
 Type: Measured
 Suspect Parameter Number: 1188
 Parameter Group Number: [65174]

spn1189 - Turbocharger 2 Wastegate Drive - Position of the wastegate drive. A value of 0% represents fully closed and a value of 100% represents fully open.

Data Length: 1 byte
 Resolution: 0.4 %/bit , 0 offset
 Data Range: 0 to 100 %
 Type: Measured
 Suspect Parameter Number: 1189
 Parameter Group Number: [65174]

spn1190 - Turbocharger 3 Wastegate Drive - Position of the wastegate drive. A value of 0% represents fully closed and a value of 100% represents fully open.

Data Length: 1 byte
 Resolution: 0.4 %/bit , 0 offset
 Data Range: 0 to 100 %
 Type: Measured
 Suspect Parameter Number: 1190
 Parameter Group Number: [65174]

spn1191 - Turbocharger 4 Wastegate Drive - Position of the wastegate drive. A value of 0% represents fully closed and a value of 100% represents fully open.

Data Length: 1 byte
 Resolution: 0.4 %/bit , 0 offset
 Data Range: 0 to 100 %
 Type: Measured
 Suspect Parameter Number: 1191
 Parameter Group Number: [65174]

spn1192 - Turbocharger Wastegate Actuator Control Air Pressure - Gage pressure of the air used to control the actuator which opens and closes the wastegate valve.

Data Length: 1 byte
 Resolution: 4 kPa/bit , 0 offset
 Data Range: 0 to 1000 kPa
 Type: Measured
 Suspect Parameter Number: 1192
 Parameter Group Number: [65174]

spn1193 - Engine Operation Time Since Rebuild - The time in engine operation since the last engine rebuild.

Data Length: 4 bytes
 Resolution: 1 s/bit , 0 offset
 Data Range: 0 to 4,211,081,215 s
 Type: Measured
 Suspect Parameter Number: 1193
 Parameter Group Number: [65173]

spn1194 - Anti-theft Encryption Seed Present Indicator - Indicates the presence of the encryption seed random number.

00 - Random number is not present
 01 - Random number is present

Bit Length: 2 bits
 Type: Status
 Suspect Parameter Number: 1194
 Parameter Group Number: [56320]

spn1195 - Anti-theft Password Valid Indicator - Indicates the presence of a validated password.

00 - Password is not a validated password
 01 - Password is a validated password

Bit Length: 2 bits
 Type: Status
 Suspect Parameter Number: 1195
 Parameter Group Number: [56320]

spn1196 - Anti-theft Component Status States - Indicates whether or not the component can be started.

00 Unlocked
 01 Locked
 10 Blocked
 11 Not defined
 00b - Unlocked = This state indicates that the component can be started without the end user being required to enter a password.
 01b - Locked = This state indicates that the component can NOT be started (i.e., Unlocked) without the end user being required to enter a password.
 10b - Blocked = This state indicates that a Lock or Unlock command cannot be executed because some other algorithm or command of higher priority is commanding differently.

Bit Length: 2 bits
 Type: Status
 Suspect Parameter Number: 1196
 Parameter Group Number: [56320]

spn1197 - Anti-theft Modify Password States - This parameter is used to indicate whether a password request was successfully performed, or if the request could not be performed due to system constraints or if the request was not a valid request.

- 00 Ok
- 01 Full_of_Passwords
- 10 Empty_of_Passwords
- 11 Not_valid
- 00b - Ok = This state indicates that the request was successfully performed.
- 01b - Full_Of_Passwords = This state indicates that the component can NOT store any additional passwords in its memory.
- 10b - Empty_Of_Passwords = This state indicates that the component would be empty of passwords (an unacceptable condition) if the password under which the end user is logged in, is deleted. Thus the delete password command is not successfully executed. Note that if the Delete_Password command is sent to a component that does not currently have a password the Empty_Of_Passwords state indicator shall be used.
- 11b - Not_Valid = This state indicates that the request is not a valid one.

Bit Length: 2 bits
 Type: Status
 Suspect Parameter Number: 1197
 Parameter Group Number: [56320]

spn1198 - Anti-theft Random Number - A seven byte random numeric code provided by the component in response to an anti-theft request. This parameter is sent as a numeric value utilizing the full range of 0 to 0xFFFFFFFFFFFFFFFF. The most significant byte is sent first, not following the rules of Table 1.

Data Length: 7 bytes
 Resolution: ASCII , 0 offset
 Data Range: 0 to 255 per byte
 Type: Status
 Suspect Parameter Number: 1198
 Parameter Group Number: [56320]

spn1199 - Anti-theft Encryption Indicator States - This parameter is used to indicate if a random number seed is being requested, or if an encrypted password is being provided to the component.

- 00 Encryption_Seed_Request
- 01 Encrypted_Code_Present
- 10 Not defined
- 11 Not_Available
- 00b - Encryption_Seed_Request = This state represents a request to the component to provide a random number seed.
- 01b - Encrypted_Code_Present = This state is used to indicate that an encrypted password is being provided to the component.
- 11b - Not_Available = This state is used to indicate that a random number is NOT being requested nor is an encrypted password being provided to the component.

Bit Length: 2 bits
 Type: Status
 Suspect Parameter Number: 1199
 Parameter Group Number: [56576]

spn1200 - Anti-theft Desired Exit Mode States - This parameter is used to specify the desired triggers that are to be used by the component in deciding when to transition to the Locked state.

- 00 Lock_Upon_Operator_Request
- 01 Lock_When_Key_Off
- 10 Not defined
- 11 Not_Available
- 00b - Lock_Upon_Operator_Request This state is used to indicate that the end user would have to manually enter a password to Lock the engine.
- 01b - Lock_When_Keyoff This state is used to indicate that the component would automatically transition to the Locked state when the end user turns off the engine (i.e. without the end user being required to manually enter the password).
- 11b - Not_Available This state is indicates that the option is not selectable or changeable by the operator via using current tool.

Bit Length: 2 bits
 Type: Status
 Suspect Parameter Number: 1200
 Parameter Group Number: [56576]

spn1201 - Anti-theft Command States - This parameter is used to identify the specific requests being sent to the component.

000 Add_Password
 001 Delete_Password
 010 Change_Password
 011 Lock_or_Unlock
 100 Check_Status
 101 Login
 110-111 Not defined

000b - Add_Password This state represents a request to the component to add a password to the list of passwords that the component has stored as valid codes. This command will not be performed if the component has already stored, the maximum number of passwords that it is capable of storing. The Login command must precede this command.

001b - Delete_Password This state represents a request to the component to delete the password (the same one used when the end-user logged in). See SPN 1197 for limitations.

010b - Change_Password This state represents a request to the component to change the password (the same one that the end-user logged in with) to a different password, which is to be specified by the end user. The Login command must precede this command.

011b - Lock_Or_Unlock This state represents a request to the component to change from the Locked state to the Unlocked state or from the Unlocked state to the Locked state.

100b - Check_Status This state represents a request to check to see if the component is in the Locked or Unlocked state.

101b - Login This state represents a request to validate the end user, before performing commands such as Add_Password and Change_Password.

Bit Length: 3 bits
 Type: Status
 Suspect Parameter Number: 1201
 Parameter Group Number: [56576]

spn1202 - Anti-theft Password Representation - This parameter is the seven byte numeric code (i.e., `encrypted password' or `key') that is generated based on the encryption algorithm, the password supplied by the end user, and the random number seed given by the component. This parameter is sent as a numeric value utilizing the full range of 0 to 0xFFFFFFFFFFFFFFFF. The most significant byte is sent first, not following the rules of Table 1.

Data Length: 7 bytes
 Resolution: ASCII , 0 offset
 Data Range: 0 to 255 per byte
 Type: Status
 Suspect Parameter Number: 1202
 Parameter Group Number: [56576]

spn1203 - Engine Auxiliary Coolant Pressure - Gage pressure of coolant found in the intercooler which is located after the turbocharger.

Data Length: 1 byte
 Resolution: 4 kPa/bit , 0 offset
 Data Range: 0 to 1000 kPa
 Type: Measured
 Suspect Parameter Number: 1203
 Parameter Group Number: [65172]

spn1204 - Electrical Load - Electrical power delivered by the engine to the electrical system connected to the generator.

Data Length: 2 bytes
 Resolution: 0.5 kW/bit , 0 offset
 Data Range: 0 to 32,127.5 kW
 Type: Measured
 Suspect Parameter Number: 1204
 Parameter Group Number: [65171]

spn1205 - Safety Wire Status - Status signal which indicates that the safety wire has been activated. When the safety wire is activated, the engine will not operate. This is used for maintenance purposes.

00 - Safety wire has not been activated
 01 - Safety wire has been activated

Bit Length: 2 bits
 Type: Status
 Suspect Parameter Number: 1205
 Parameter Group Number: [65171]

spn1206 - Turning Gear Engaged - Status signal which indicates that the turning gear is engaged. The turning gear is used to turn the flywheel/crankshaft, for maintenance purposes, while the engine is not running.

00 - Turning gear is not engaged
 01 - Turning gear is engaged

Bit Length: 2 bits
 Type: Status
 Suspect Parameter Number: 1206
 Parameter Group Number: [65171]

spn1207 - Engine ECU Temperature (OBSOLETE use SPN 1136) - Temperature of the engine electronic control unit. (21, 1207 are not to be used - obsolete)

Data Length: 2 bytes
 Resolution: 0.03125 deg C/bit , -273 deg C offset
 Data Range: -273 to 1735 deg C
 Type: Measured
 Suspect Parameter Number: 1207
 Parameter Group Number: []

spn1208 - Pre-filter Oil Pressure - Gage pressure of the engine oil before the oil reaches the oil filter.

Data Length: 1 byte
 Resolution: 4 kPa/bit , 0 offset
 Data Range: 0 to 1000 kPa
 Type: Measured
 Suspect Parameter Number: 1208
 Parameter Group Number: [65170]

spn1209 - Exhaust Gas Pressure - Gage pressure of the exhaust gasses as measured at the turbine inlet of the turbocharger.

Data Length: 2 bytes

Resolution: 1/128 kPa/bit , -250 kPa offset
 Data Range: -250 kPa TO 251.99 kPa
 Type: Measured
 Suspect Parameter Number: 1209
 Parameter Group Number: [65170]

spn1210 - Fuel Rack Position - Measured position of the engine fuel rack. A value of 0% rack represents no fueling and a value of 100% rack represents maximum fueling.

Data Length: 1 byte
 Resolution: 0.4 %/bit , 0 offset
 Data Range: 0 to 100 %
 Type: Measured
 Suspect Parameter Number: 1210
 Parameter Group Number: [65170]

spn1211 - Engine Build Hours Reset - Command signal used to reset the engine rebuild hours.

00 Do not reset
 01 Reset
 11 Take no action

Bit Length: 2 bits
 Type: Status
 Suspect Parameter Number: 1211
 Parameter Group Number: [56832]

spn1212 - Engine Auxiliary Coolant Temperature - Temperature of coolant found in the intercooler which is located after the turbocharger.

Data Length: 1 byte
 Resolution: 1 deg C/bit , -40 deg C offset
 Data Range: -40 to 210 deg C
 Type: Measured
 Suspect Parameter Number: 1212
 Parameter Group Number: [65172]

spn1237 - Engine Shutdown Override Switch - Switch signal which indicates the position of the engine shutdown override switch. This switch function allows the operator to override an impending engine shutdown.

00 - Off
 01 - On

Bit Length: 2 bits
 Type: Measured
 Suspect Parameter Number: 1237
 Parameter Group Number: [65265]

spn1238 - Traction Control Override Switch - Switch signal which indicates the position of the traction control override switch. The traction control override signal disables the automatic traction control function allowing the wheels to spin.

00- off
 01- on
 10 - Error

11 - Not available or not installed

Bit Length: 2 bits
 Type: Measured
 Suspect Parameter Number: 1238
 Parameter Group Number: [61441]

spn1239 - Fuel Leakage 1 - Status signal which indicates fuel leakage in the fuel rail of the engine. The location can be either before or after the fuel pump.

00 - no leakage detected
 01 - leakage detected

Bit Length: 2 bits
 Type: Status
 Suspect Parameter Number: 1239
 Parameter Group Number: [65169]

spn1240 - Fuel Leakage 2 - Status signal which indicates fuel leakage in the fuel rail of the engine. The location can be either before or after the fuel pump.

00 - no leakage detected
 01 - leakage detected

Bit Length: 2 bits
 Type: Status
 Suspect Parameter Number: 1240
 Parameter Group Number: [65169]

spn1241 - Mass Flow (Gaseous) - Mass flow of natural gas to the engine.

Data Length: 2 bytes
 Resolution: 0.05 kg/h per bit , 0 offset
 Data Range: 0 to 3212.75 kg/h
 Type: Measured
 Suspect Parameter Number: 1241
 Parameter Group Number: [65170]

spn1242 - Instantaneous Estimated Brake Power - Estimate of the power developed by the engine.

Data Length: 2 bytes
 Resolution: 0.5 kW/bit , 0 offset
 Data Range: 0 to 32,127.5 kW
 Type: Measured
 Suspect Parameter Number: 1242
 Parameter Group Number: [65170]

spn1243 - ABS Fully Operational - Signal which indicates whether an ABS system is fully operational or whether its functionality is reduced by a defect or by an intended action (e.g., by activation of an ABS-off-road switch or during special diagnostic procedures). There are cases where the signal is necessary to fulfill legal regulations for special applications (e.g., switching off integrated retarders).

00 - Not Fully Operational
 01 - Fully Operational

Bit Length: 2 bits

Type: Status
 Suspect Parameter Number: 1243
 Parameter Group Number: [61441]

spn1246 - Number of Torque History Records - Number of torque history records contained in the engine torque history PGN. A value of 0 is broadcast if no torque history records are stored in the ECU.

Data Length: 1 byte
 Resolution: 1 record/bit , 0 offset
 Data Range: 0 to 250 records
 Type: Measured
 Suspect Parameter Number: 1246
 Parameter Group Number: [65168]

spn1247 - Engine Power - Advertised engine power capability. Advertised power is what a customer will find on a sales sheet for an engine with a certain calibration.

Data Length: 2 bytes
 Resolution: 0.5 kW/bit , 0 offset
 Data Range: 0 to 32,127.5 kW
 Type: Measured
 Suspect Parameter Number: 1247
 Parameter Group Number: [65168]

spn1248 - Peak Engine Torque 1 - Maximum torque output of the current ECU calibration when the engine operates on torque curve 1. For calibrations that support two torque curves, this parameter shall be assigned the value of the lower curve. For calibrations that support only one curve, this parameter should be used.

Data Length: 2 bytes
 Resolution: 1 Nm/bit , 0 offset
 Data Range: 0 to 64,255 Nm
 Type: Measured
 Suspect Parameter Number: 1248
 Parameter Group Number: [65168]

spn1249 - Peak Engine Torque 2 - Maximum torque output of the current ECU calibration when the engine operates on torque curve 2. For calibrations that support two torque curves, this parameter shall be assigned the value of the higher curve. For calibrations that support only one curve, this parameter should to set to 'not available'.

Data Length: 2 bytes
 Resolution: 1 Nm/bit , 0 offset
 Data Range: 0 to 64,255 Nm
 Type: Measured
 Suspect Parameter Number: 1249
 Parameter Group Number: [65168]

spn1250 - Calibration Record Start Month - Calendar month timestamp when an ECU record was established. NOTE - A value of 0 for the month is null. The value 1 identifies January; 2 identifies February; etc.

Data Length:	1 byte
Resolution:	1 month/bit , 0 offset
Data Range:	0 to 250 months
Operating Range:	1 to 12 month
Type:	Measured
Suspect Parameter Number:	1250
Parameter Group Number:	[65168]

spn1251 - Calibration Record Start Day - Calendar day timestamp when an ECU record was established. NOTE - A value of 0 for the date is null. The values 1, 2, 3, and 4 are used to identify the first day of the month; 5, 6, 7, and 8 identify the second day of the month; etc.

Data Length:	1 byte
Resolution:	0.25 days/bit , 0 offset
Data Range:	0 to 62.5 days
Operating Range:	0.25 to 31.75 day
Type:	Measured
Suspect Parameter Number:	1251
Parameter Group Number:	[65168]

spn1252 - Calibration Record Start Year - Calendar year timestamp when an ECU record was established. NOTE - A value of 0 for the year identifies the year 1985; a value of 1 identifies 1986; etc.

Data Length:	1 byte
Resolution:	1 year/bit , 1985 years offset
Data Range:	1985 to 2235 years
Operating Range:	1985 to 2235 year
Type:	Measured
Suspect Parameter Number:	1252
Parameter Group Number:	[65168]

spn1253 - Calibration Record Duration Time - Duration in hours for which the engine operated in the conditions captured in the current record.

Data Length:	4 bytes
Resolution:	0.05 hr/bit , 0 offset
Data Range:	0 to 210,554,060.75 hr
Type:	Measured
Suspect Parameter Number:	1253
Parameter Group Number:	[65168]

spn1254 - Torque Limiting Feature Status - Status of an ECU feature which limits the torque output of the engine.

00 - Disabled
01 - Enabled

Bit Length:	2 bits
Type:	Status
Suspect Parameter Number:	1254
Parameter Group Number:	[65168]

spn1255 - Transmission Gear Ratio 1 - Gear ratio value stored in the ECU that is used to define a range of transmission gears for which a limit is applied to the engine output torque. Transmission gear ratio 1 should be the numerically highest transmission gear ratio breakpoint that defines ratio ranges for torque limits.

Data Length: 2 bytes
 Resolution: 0.01/bit , 0 offset
 Data Range: 0 to 642.55
 Type: Measured
 Suspect Parameter Number: 1255
 Parameter Group Number: [65168]

spn1256 - Engine Torque Limit 1, Transmission - Limit applied to the engine output torque during vehicle operation in transmission gear ratios numerically greater than transmission gear ratio 1 (see SPN 1255).

Data Length: 2 bytes
 Resolution: 1 Nm/bit , 0 offset
 Data Range: 0 to 64,255 Nm
 Type: Measured
 Suspect Parameter Number: 1256
 Parameter Group Number: [65168]

spn1257 - Transmission Gear Ratio 2 - Gear ratio value stored in the ECU that is used to define a range of transmission gears for which a limit is applied to the engine output torque. Transmission gear ratio 2 should be the numerically highest transmission gear ratio breakpoint less than transmission gear ratio 1 (see SPN 1255) that defines ratio ranges for torque limits.

Data Length: 2 bytes
 Resolution: 0.01/bit , 0 offset
 Data Range: 0 to 642.55
 Type: Measured
 Suspect Parameter Number: 1257
 Parameter Group Number: [65168]

spn1258 - Engine Torque Limit 2, Transmission - Limit applied to the engine output torque during vehicle operation in transmission gear ratios numerically less than or equal to transmission gear ratio 1 (see SPN 1255) and numerically greater than transmission gear ratio 2 (see SPN 1257). For example, with transmission gear ratio 1 equal to 12.0:1 and transmission gear ratio 2 equal to 5.0:1, vehicle operation in a transmission gear with a ratio of 6.0:1 will result in the application of engine torque limit 2, transmission.

Data Length: 2 bytes
 Resolution: 1 Nm/bit , 0 offset
 Data Range: 0 to 64,255 Nm
 Type: Measured
 Suspect Parameter Number: 1258
 Parameter Group Number: [65168]

spn1259 - Transmission Gear Ratio 3 - Gear ratio value stored in the ECU that is used to define a range of transmission gears for which a limit is applied to the engine output torque. Transmission gear ratio 3 should be the numerically highest transmission gear ratio breakpoint less than transmission gear ratio 2 (see SPN 1257) that defines ratio ranges for torque limits.

Data Length: 2 bytes
 Resolution: 0.01/bit , 0 offset
 Data Range: 0 to 642.55
 Type: Measured
 Suspect Parameter Number: 1259
 Parameter Group Number: [65168]

spn1260 - Engine Torque Limit 3, Transmission - Limit applied to the engine output torque during vehicle operation in transmission gear ratios numerically less than or equal to transmission gear ratio 2 (see SPN 1257) and numerically greater than transmission gear ratio 3 (see.SPN 1259). For example, with transmission gear ratio 2 equal to 5.0:1 and transmission gear ratio 3 equal to 2.0:1, vehicle operation in a transmission gear with a ratio of 3.0:1 will result in the application of engine torque limit 3, transmission.

Data Length: 2 bytes
 Resolution: 1 Nm/bit , 0 offset
 Data Range: 0 to 64,255 Nm
 Type: Measured
 Suspect Parameter Number: 1260
 Parameter Group Number: [65168]

spn1261 - Engine Torque Limit 4, Transmission - Limit applied to the engine output torque during vehicle operation in transmission gear ratios numerically less than or equal to transmission gear ratio 3 (see SPN 1259).

Data Length: 2 bytes
 Resolution: 1 Nm/bit , 0 offset
 Data Range: 0 to 64,255 Nm
 Type: Measured
 Suspect Parameter Number: 1261
 Parameter Group Number: [65168]

spn1262 - Engine Torque Limit 5, Switch - Limit applied to the engine output torque based on activation of an ECU switch input.

Data Length: 2 bytes
 Resolution: 1 Nm/bit , 0 offset
 Data Range: 0 to 64,255 Nm
 Type: Measured
 Suspect Parameter Number: 1262
 Parameter Group Number: [65168]

spn1263 - Engine Torque Limit 6, Axle Input - Limit applied to the engine output torque based on the maximum allowable axle input torque. Axle input torque is calculated as the current engine torque output multiplied by the transmission gear ratio.

Data Length: 2 bytes
 Resolution: 2 Nm/bit , 0 offset
 Data Range: 0 to 128,510 Nm
 Type: Measured
 Suspect Parameter Number: 1263

Parameter Group Number: [65168]

spn1264 - Extended Crankcase Blow-by Pressure - duplicate (see SPN 22) - Differential crankcase blow-by pressure as measured through a tube with a venturi. (1264 not to be used ' obsolete)

Data Length: 1 byte
 Resolution: 0.05 kPa/bit , 0 offset
 Data Range: 0 to 12.5 kPa
 Type: Measured
 Suspect Parameter Number: 1264
 Parameter Group Number: []

spn1320 - Externally Supplied Air Pressure - Pressure of the air used to shut off the fuel supply to the engine.

Data Length: 2 bytes
 Resolution: 0.5 kPa/bit , 0 offset
 Data Range: 0 to 32,127.5 kPa
 Type: Measured
 Suspect Parameter Number: 1320
 Parameter Group Number: [65167]

spn1349 - Injector Metering Rail 2 Pressure - The gage pressure of fuel in the metering rail #2 as delivered from the supply pump to the injector metering inlet. See Figure SPN1381_A for fuel system related parameters. Although the figure does not show rail #2 it does show the relationship of rail pressure to other signals.

Data Length: 2 bytes
 Resolution: 1/256 MPa/bit , 0 offset
 Data Range: 0 to 251 Mpa
 Type: Measured
 Suspect Parameter Number: 1349
 Parameter Group Number: [65243]

spn1350 - Time Since Last Service - The vehicle operation time since the last service was performed. The type of service information is identified by the service component identification number.

Data Length: 2 bytes
 Resolution: 1 hr/bit , -32,127 hr offset
 Data Range: -32,127 to 32,128 hr
 Type: Measured
 Suspect Parameter Number: 1350
 Parameter Group Number: [65166]

spn1376 - Battery 2 Potential (Voltage) (duplicate - see also SPN 444) - The voltage for isolated battery #2.

Data Length: 2 bytes
 Resolution: 0.05 V/bit , 0 offset
 Data Range: 0 to 3212.75 V
 Type: Measured
 Suspect Parameter Number: 1376

Parameter Group Number: []

spn1379 - Service Component Identification - Identification of component needing service. See Table SPN911_A.

Data Length: 1 byte
 Resolution: 1 ID/bit , 0 offset
 Data Range: 0 to 250 ID
 Type: Measured
 Suspect Parameter Number: 1379
 Parameter Group Number: [65166]

spn1380 - Engine Oil Level Remote Reservoir - Ratio of current volume of engine oil in a remote reservoir to the maximum required volume. If a single switch (on/off) is used, 20% and 100% respectively will be used where 100% means no oil needs to be added and 20% means oil needs to be added. If two switches are used, 20%, 50%, and 100% will be used where 20% indicates the oil is critically low, 50% indicates the oil level is low, and 100% means no oil needs to be added. For continuous sensors, the actual measured percent will be used.

Data Length: 1 byte
 Resolution: 0.4 %/bit , 0 offset
 Data Range: 0 to 100 %
 Type: Measured
 Suspect Parameter Number: 1380
 Parameter Group Number: [65130]

spn1381 - Fuel Supply Pump Inlet Pressure - Absolute pressure of fuel at the fuel supply pump inlet. See Figures SPN16_A & SPN16_B

Data Length: 1 byte
 Resolution: 2 kPa/bit , 0 offset
 Data Range: 0 to 500 kPa
 Type: Measured
 Suspect Parameter Number: 1381
 Parameter Group Number: [65130]

spn1382 - Fuel Filter (suction side) Differential Pressure - Differential pressure measured across the fuel filter located between the fuel tank and the supply pump. See Figures SPN16_A and SPN16_B.

Data Length: 1 byte
 Resolution: 2 kPa/bit , 0 offset
 Data Range: 0 to 500 kPa
 Type: Measured
 Suspect Parameter Number: 1382
 Parameter Group Number: [65130]

spn1385 - Auxiliary Temperature #1 (duplicate see also SPN 441) - Temperature measured by auxiliary temperature sensor #1 or #2. Not to be used in place of existing SPNs.

Data Length: 1 byte
 Resolution: 1 deg C/bit , -40 deg C offset

Data Range: -40 to 210 deg C
 Type: Measured
 Suspect Parameter Number: 1385
 Parameter Group Number: []

spn1386 - Auxiliary Temperature #2 (duplicate see also SPN 442) - Temperature measured by auxiliary temperature sensor #1 or #2. Not to be used in place of existing SPNs.

Data Length: 1 byte
 Resolution: 1 deg C/bit , -40 deg C offset
 Data Range: -40 to 210 deg C
 Type: Measured
 Suspect Parameter Number: 1386
 Parameter Group Number: []

spn1387 - Auxiliary Pressure #1 - Pressure measured by auxiliary pressure sensor #1. Not to be used in place of existing SPNs.

Data Length: 1 byte
 Resolution: 16 kPa/bit , 0 offset
 Data Range: 0 to 4000 kPa
 Type: Measured
 Suspect Parameter Number: 1387
 Parameter Group Number: [65164]

spn1388 - Auxiliary Pressure #2 - Pressure measured by auxiliary pressure sensor #2. Not to be used in place of existing SPNs.

Data Length: 1 byte
 Resolution: 16 kPa/bit , 0 offset
 Data Range: 0 to 4000 kPa
 Type: Measured
 Suspect Parameter Number: 1388
 Parameter Group Number: [65164]

spn1389 - Fuel Specific Gravity - This parameter conveys the specific gravity of the gaseous fuel being used by the engine. The specific gravity of the fuel can then be used to compute the density of the fuel.

Data Length: 2 bytes
 Resolution: 0.0001/bit , 0 offset
 Data Range: 0 to 6.4255
 Operating Range: 0 to 2.0000
 Type: Status
 Suspect Parameter Number: 1389
 Parameter Group Number: [65202]

spn1390 - Absolute Fuel Valve Inlet Pressure - The absolute pressure at the inlet of the gaseous fuel valve.

Data Length: 2 bytes

Resolution: 0.1 kPa/bit , 0 offset
 Data Range: 0 to 6,425.5 kPa
 Type: Measured
 Suspect Parameter Number: 1390
 Parameter Group Number: [65163]

spn1391 - Outlet to Inlet Fuel Valve Differential Pressure - The differential pressure between the inlet and the outlet of a gaseous fuel valve.

Data Length: 2 bytes
 Resolution: 0.1 kPa/bit , 0 offset
 Data Range: 0 to 6,425.5 kPa
 Type: Measured
 Suspect Parameter Number: 1391
 Parameter Group Number: [65163]

spn1392 - Air to Fuel Differential Pressure - The differential pressure between the gaseous fuel and the air intake manifold.

Data Length: 2 bytes
 Resolution: 0.1 kPa/bit , 0 offset
 Data Range: 0 to 6,425.5 kPa
 Type: Measured
 Suspect Parameter Number: 1392
 Parameter Group Number: [65163]

spn1393 - Cylinder 1 Ignition Transformer Secondary Output - This parameter indicates the relative intensity of the secondary output voltage of the ignition transformer.

Data Length: 1 byte
 Resolution: 1 %/bit , -125% offset
 Data Range: -125 to 125 %
 Type: Measured
 Suspect Parameter Number: 1393
 Parameter Group Number: [65160]

spn1394 - Cylinder 2 Ignition Transformer Secondary Output - This parameter indicates the relative intensity of the secondary output voltage of the ignition transformer.

Data Length: 1 byte
 Resolution: 1 %/bit , -125% offset
 Data Range: -125 to 125 %
 Type: Measured
 Suspect Parameter Number: 1394
 Parameter Group Number: [65160]

spn1395 - Cylinder 3 Ignition Transformer Secondary Output - This parameter indicates the relative intensity of the secondary output voltage of the ignition transformer.

Data Length: 1 byte
 Resolution: 1 %/bit , -125% offset
 Data Range: -125 to 125 %
 Type: Measured
 Suspect Parameter Number: 1395
 Parameter Group Number: [65160]

spn1396 - Cylinder 4 Ignition Transformer Secondary Output - This parameter indicates the relative intensity of the secondary output voltage of the ignition transformer.

Data Length: 1 byte
 Resolution: 1 %/bit , -125% offset
 Data Range: -125 to 125 %
 Type: Measured
 Suspect Parameter Number: 1396
 Parameter Group Number: [65160]

spn1397 - Cylinder 5 Ignition Transformer Secondary Output - This parameter indicates the relative intensity of the secondary output voltage of the ignition transformer.

Data Length: 1 byte
 Resolution: 1 %/bit , -125% offset
 Data Range: -125 to 125 %
 Type: Measured
 Suspect Parameter Number: 1397
 Parameter Group Number: [65160]

spn1398 - Cylinder 6 Ignition Transformer Secondary Output - This parameter indicates the relative intensity of the secondary output voltage of the ignition transformer.

Data Length: 1 byte
 Resolution: 1 %/bit , -125% offset
 Data Range: -125 to 125 %
 Type: Measured
 Suspect Parameter Number: 1398
 Parameter Group Number: [65160]

spn1399 - Cylinder 7 Ignition Transformer Secondary Output - This parameter indicates the relative intensity of the secondary output voltage of the ignition transformer.

Data Length: 1 byte
 Resolution: 1 %/bit , -125% offset
 Data Range: -125 to 125 %
 Type: Measured
 Suspect Parameter Number: 1399
 Parameter Group Number: [65160]

spn1400 - Cylinder 8 Ignition Transformer Secondary Output - This parameter indicates the relative intensity of

the secondary output voltage of the ignition transformer.

Data Length: 1 byte
 Resolution: 1 %/bit , -125% offset
 Data Range: -125 to 125 %
 Type: Measured
 Suspect Parameter Number: 1400
 Parameter Group Number: [65160]

spn1401 - Cylinder 9 Ignition Transformer Secondary Output - This parameter indicates the relative intensity of the secondary output voltage of the ignition transformer.

Data Length: 1 byte
 Resolution: 1 %/bit , -125% offset
 Data Range: -125 to 125 %
 Type: Measured
 Suspect Parameter Number: 1401
 Parameter Group Number: [65161]

spn1402 - Cylinder 10 Ignition Transformer Secondary Output - This parameter indicates the relative intensity of the secondary output voltage of the ignition transformer.

Data Length: 1 byte
 Resolution: 1 %/bit , -125% offset
 Data Range: -125 to 125 %
 Type: Measured
 Suspect Parameter Number: 1402
 Parameter Group Number: [65161]

spn1403 - Cylinder 11 Ignition Transformer Secondary Output - This parameter indicates the relative intensity of the secondary output voltage of the ignition transformer.

Data Length: 1 byte
 Resolution: 1 %/bit , -125% offset
 Data Range: -125 to 125 %
 Type: Measured
 Suspect Parameter Number: 1403
 Parameter Group Number: [65161]

spn1404 - Cylinder 12 Ignition Transformer Secondary Output - This parameter indicates the relative intensity of the secondary output voltage of the ignition transformer.

Data Length: 1 byte
 Resolution: 1 %/bit , -125% offset
 Data Range: -125 to 125 %
 Type: Measured
 Suspect Parameter Number: 1404
 Parameter Group Number: [65161]

spn1405 - Cylinder 13 Ignition Transformer Secondary Output - This parameter indicates the relative intensity of the secondary output voltage of the ignition transformer.

Data Length: 1 byte
 Resolution: 1 %/bit , -125% offset
 Data Range: -125 to 125 %
 Type: Measured
 Suspect Parameter Number: 1405
 Parameter Group Number: [65161]

spn1406 - Cylinder 14 Ignition Transformer Secondary Output - This parameter indicates the relative intensity of the secondary output voltage of the ignition transformer.

Data Length: 1 byte
 Resolution: 1 %/bit , -125% offset
 Data Range: -125 to 125 %
 Type: Measured
 Suspect Parameter Number: 1406
 Parameter Group Number: [65161]

spn1407 - Cylinder 15 Ignition Transformer Secondary Output - This parameter indicates the relative intensity of the secondary output voltage of the ignition transformer.

Data Length: 1 byte
 Resolution: 1 %/bit , -125% offset
 Data Range: -125 to 125 %
 Type: Measured
 Suspect Parameter Number: 1407
 Parameter Group Number: [65161]

spn1408 - Cylinder 16 Ignition Transformer Secondary Output - This parameter indicates the relative intensity of the secondary output voltage of the ignition transformer.

Data Length: 1 byte
 Resolution: 1 %/bit , -125% offset
 Data Range: -125 to 125 %
 Type: Measured
 Suspect Parameter Number: 1408
 Parameter Group Number: [65161]

spn1409 - Cylinder 17 Ignition Transformer Secondary Output - This parameter indicates the relative intensity of the secondary output voltage of the ignition transformer.

Data Length: 1 byte
 Resolution: 1 %/bit , -125% offset
 Data Range: -125 to 125 %
 Type: Measured
 Suspect Parameter Number: 1409
 Parameter Group Number: [65162]

spn1410 - Cylinder 18 Ignition Transformer Secondary Output - This parameter indicates the relative intensity of the secondary output voltage of the ignition transformer.

Data Length: 1 byte
 Resolution: 1 %/bit , -125% offset
 Data Range: -125 to 125 %
 Type: Measured
 Suspect Parameter Number: 1410
 Parameter Group Number: [65162]

spn1411 - Cylinder 19 Ignition Transformer Secondary Output - This parameter indicates the relative intensity of the secondary output voltage of the ignition transformer.

Data Length: 1 byte
 Resolution: 1 %/bit , -125% offset
 Data Range: -125 to 125 %
 Type: Measured
 Suspect Parameter Number: 1411
 Parameter Group Number: [65162]

spn1412 - Cylinder 20 Ignition Transformer Secondary Output - This parameter indicates the relative intensity of the secondary output voltage of the ignition transformer.

Data Length: 1 byte
 Resolution: 1 %/bit , -125% offset
 Data Range: -125 to 125 %
 Type: Measured
 Suspect Parameter Number: 1412
 Parameter Group Number: [65162]

spn1413 - Cylinder 1 Ignition Timing - The ignition timing of the cylinder.

Data Length: 2 bytes
 Resolution: 1/128 deg/bit , -200 deg offset
 Data Range: -200 to 301.99 deg
 Type: Status
 Suspect Parameter Number: 1413
 Parameter Group Number: [65154]

spn1414 - Cylinder 2 Ignition Timing - The ignition timing of the cylinder.

Data Length: 2 bytes
 Resolution: 1/128 deg/bit , -200 deg offset
 Data Range: -200 to 301.99 deg
 Type: Status
 Suspect Parameter Number: 1414
 Parameter Group Number: [65154]

spn1415 - Cylinder 3 Ignition Timing - The ignition timing of the cylinder.

Data Length: 2 bytes
 Resolution: 1/128 deg/bit , -200 deg offset
 Data Range: -200 to 301.99 deg
 Type: Status
 Suspect Parameter Number: 1415
 Parameter Group Number: [65154]

spn1416 - Cylinder 4 Ignition Timing - The ignition timing of the cylinder.

Data Length: 2 bytes
 Resolution: 1/128 deg/bit , -200 deg offset
 Data Range: -200 to 301.99 deg
 Type: Status
 Suspect Parameter Number: 1416
 Parameter Group Number: [65154]

spn1417 - Cylinder 5 Ignition Timing - The ignition timing of the cylinder.

Data Length: 2 bytes
 Resolution: 1/128 deg/bit , -200 deg offset
 Data Range: -200 to 301.99 deg
 Type: Status
 Suspect Parameter Number: 1417
 Parameter Group Number: [65155]

spn1418 - Cylinder 6 Ignition Timing - The ignition timing of the cylinder.

Data Length: 2 bytes
 Resolution: 1/128 deg/bit , -200 deg offset
 Data Range: -200 to 301.99 deg
 Type: Status
 Suspect Parameter Number: 1418
 Parameter Group Number: [65155]

spn1419 - Cylinder 7 Ignition Timing - The ignition timing of the cylinder.

Data Length: 2 bytes
 Resolution: 1/128 deg/bit , -200 deg offset
 Data Range: -200 to 301.99 deg
 Type: Status
 Suspect Parameter Number: 1419
 Parameter Group Number: [65155]

spn1420 - Cylinder 8 Ignition Timing - The ignition timing of the cylinder.

Data Length: 2 bytes
 Resolution: 1/128 deg/bit , -200 deg offset
 Data Range: -200 to 301.99 deg
 Type: Status

Suspect Parameter Number: 1420
 Parameter Group Number: [65155]

spn1421 - Cylinder 9 Ignition Timing - The ignition timing of the cylinder.

Data Length: 2 bytes
 Resolution: 1/128 deg/bit , -200 deg offset
 Data Range: -200 to 301.99 deg
 Type: Status
 Suspect Parameter Number: 1421
 Parameter Group Number: [65156]

spn1422 - Cylinder 10 Ignition Timing - The ignition timing of the cylinder.

Data Length: 2 bytes
 Resolution: 1/128 deg/bit , -200 deg offset
 Data Range: -200 to 301.99 deg
 Type: Status
 Suspect Parameter Number: 1422
 Parameter Group Number: [65156]

spn1423 - Cylinder 11 Ignition Timing - The ignition timing of the cylinder.

Data Length: 2 bytes
 Resolution: 1/128 deg/bit , -200 deg offset
 Data Range: -200 to 301.99 deg
 Type: Status
 Suspect Parameter Number: 1423
 Parameter Group Number: [65156]

spn1424 - Cylinder 12 Ignition Timing - The ignition timing of the cylinder.

Data Length: 2 bytes
 Resolution: 1/128 deg/bit , -200 deg offset
 Data Range: -200 to 301.99 deg
 Type: Status
 Suspect Parameter Number: 1424
 Parameter Group Number: [65156]

spn1425 - Cylinder 13 Ignition Timing - The ignition timing of the cylinder.

Data Length: 2 bytes
 Resolution: 1/128 deg/bit , -200 deg offset
 Data Range: -200 to 301.99 deg
 Type: Status
 Suspect Parameter Number: 1425
 Parameter Group Number: [65157]

spn1426 - Cylinder 14 Ignition Timing - The ignition timing of the cylinder.

Data Length: 2 bytes
 Resolution: 1/128 deg/bit , -200 deg offset
 Data Range: -200 to 301.99 deg
 Type: Status
 Suspect Parameter Number: 1426
 Parameter Group Number: [65157]

spn1427 - Cylinder 15 Ignition Timing - The ignition timing of the cylinder.

Data Length: 2 bytes
 Resolution: 1/128 deg/bit , -200 deg offset
 Data Range: -200 to 301.99 deg
 Type: Status
 Suspect Parameter Number: 1427
 Parameter Group Number: [65157]

spn1428 - Cylinder 16 Ignition Timing - The ignition timing of the cylinder.

Data Length: 2 bytes
 Resolution: 1/128 deg/bit , -200 deg offset
 Data Range: -200 to 301.99 deg
 Type: Status
 Suspect Parameter Number: 1428
 Parameter Group Number: [65157]

spn1429 - Cylinder 17 Ignition Timing - The ignition timing of the cylinder.

Data Length: 2 bytes
 Resolution: 1/128 deg/bit , -200 deg offset
 Data Range: -200 to 301.99 deg
 Type: Status
 Suspect Parameter Number: 1429
 Parameter Group Number: [65158]

spn1430 - Cylinder 18 Ignition Timing - The ignition timing of the cylinder.

Data Length: 2 bytes
 Resolution: 1/128 deg/bit , -200 deg offset
 Data Range: -200 to 301.99 deg
 Type: Status
 Suspect Parameter Number: 1430
 Parameter Group Number: [65158]

spn1431 - Cylinder 19 Ignition Timing - The ignition timing of the cylinder.

Data Length: 2 bytes
 Resolution: 1/128 deg/bit , -200 deg offset
 Data Range: -200 to 301.99 deg
 Type: Status

Suspect Parameter Number: 1431
 Parameter Group Number: [65158]

spn1432 - Cylinder 20 Ignition Timing - The ignition timing of the cylinder.

Data Length: 2 bytes
 Resolution: 1/128 deg/bit , -200 deg offset
 Data Range: -200 to 301.99 deg
 Type: Status
 Suspect Parameter Number: 1432
 Parameter Group Number: [65158]

spn1433 - Desired Ignition Timing #1 - A programmable timing value specific to the engine's application. Factors affecting this value include both fuel type and the nature of the load being driven.

Data Length: 2 bytes
 Resolution: 1/128 deg/bit , -200 deg offset
 Data Range: -200 to 301.99 deg
 Type: Status
 Suspect Parameter Number: 1433
 Parameter Group Number: [65159]

spn1434 - Desired Ignition Timing #2 - A programmable timing value specific to the engine's application. Factors affecting this value include both fuel type and the nature of the load being driven.

Data Length: 2 bytes
 Resolution: 1/128 deg/bit , -200 deg offset
 Data Range: -200 to 301.99 deg
 Type: Status
 Suspect Parameter Number: 1434
 Parameter Group Number: [65159]

spn1435 - Desired Ignition Timing #3 - A programmable timing value specific to the engine's application. Factors affecting this value include both fuel type and the nature of the load being driven.

Data Length: 2 bytes
 Resolution: 1/128 deg/bit , -200 deg offset
 Data Range: -200 to 301.99 deg
 Type: Status
 Suspect Parameter Number: 1435
 Parameter Group Number: [65159]

spn1436 - Actual Ignition Timing - The actual ignition timing at the current engine conditions. This parameter may or may not be equal to one of the desired timing parameters (see SPNs 1433-1435), depending on the status of the engine.

Data Length: 2 bytes
 Resolution: 1/128 deg/bit , -200 deg offset
 Data Range: -200 to 301.99 deg
 Type: Status

Suspect Parameter Number: 1436
 Parameter Group Number: [65159]

spn1437 - Road Speed Limit Status - Status (active or not active) of the system used to limit maximum vehicle velocity.

00 - Active
 01 - Not Active

NOTE - While somewhat inconsistent with other J1939 status parameters, the states defining 00 = active and 01 = inactive for Road Speed Limit Status are NOT typographical errors, and should be implemented as stated.

Bit Length: 2 bits
 Type: Status
 Suspect Parameter Number: 1437
 Parameter Group Number: [61443]

spn1438 - ABS/EBS Amber Warning Signal (Powered Vehicle) - This parameter commands the ABS/EBS amber/yellow optical warning signal

00 Off
 01 On
 10 Reserved
 11 Take no action

Bit Length: 2 bits
 Type: Status
 Suspect Parameter Number: 1438
 Parameter Group Number: [61441]

spn1439 - EBS Red Warning Signal - This parameter commands the EBS red optical warning signal

00 Off
 01 On
 10 Reserved
 11 Take no action

Bit Length: 2 bits
 Type: Status
 Suspect Parameter Number: 1439
 Parameter Group Number: [61441]

spn1440 - Fuel Flow Rate 1 - The rate at which the fuel is flowing through a fuel valve.

Data Length: 2 bytes
 Resolution: 0.1 m³/h per bit , 0 offset
 Data Range: 0 to 6425.5 m³/h
 Type: Measured
 Suspect Parameter Number: 1440
 Parameter Group Number: [65153]

spn1441 - Fuel Flow Rate 2 - The rate at which the fuel is flowing through a fuel valve.

Data Length: 2 bytes
 Resolution: 0.1 m³/h per bit , 0 offset
 Data Range: 0 to 6425.5 m³/h
 Type: Measured
 Suspect Parameter Number: 1441

Parameter Group Number: [65153]

spn1442 - Fuel Valve 1 Position - The position of a gaseous fuel valve that is metering the fuel flow to the engine. 0% indicates no fuel flow through valve and 100% means maximum fuel flow through valve.

Data Length: 1 byte
 Resolution: 0.4 %/bit , 0 offset
 Data Range: 0 to 100 %
 Type: Measured
 Suspect Parameter Number: 1442
 Parameter Group Number: [65153]

spn1443 - Fuel Valve 2 Position - The position of a gaseous fuel valve that is metering the fuel flow to the engine. 0% indicates no fuel flow through valve and 100% means maximum fuel flow through valve.

Data Length: 1 byte
 Resolution: 0.4 %/bit , 0 offset
 Data Range: 0 to 100 %
 Type: Measured
 Suspect Parameter Number: 1443
 Parameter Group Number: [65153]

spn1444 - Cylinder 1 Combustion Time - The amount of time from when the ignition of the fuel is initiated to when the fuel is completely ignited (i.e., the flame front has propagated across the cylinder).

Data Length: 2 bytes
 Resolution: 0.01 ms/bit , 0 offset
 Data Range: 0 to 642.55 ms
 Type: Measured
 Suspect Parameter Number: 1444
 Parameter Group Number: [65147]

spn1445 - Cylinder 2 Combustion Time - The amount of time from when the ignition of the fuel is initiated to when the fuel is completely ignited (i.e., the flame front has propagated across the cylinder).

Data Length: 2 bytes
 Resolution: 0.01 ms/bit , 0 offset
 Data Range: 0 to 642.55 ms
 Type: Measured
 Suspect Parameter Number: 1445
 Parameter Group Number: [65147]

spn1446 - Cylinder 3 Combustion Time - The amount of time from when the ignition of the fuel is initiated to when the fuel is completely ignited (i.e., the flame front has propagated across the cylinder).

Data Length: 2 bytes
 Resolution: 0.01 ms/bit , 0 offset
 Data Range: 0 to 642.55 ms
 Type: Measured

Suspect Parameter Number: 1446
 Parameter Group Number: [65147]

spn1447 - Cylinder 4 Combustion Time - The amount of time from when the ignition of the fuel is initiated to when the fuel is completely ignited (i.e., the flame front has propagated across the cylinder).

Data Length: 2 bytes
 Resolution: 0.01 ms/bit , 0 offset
 Data Range: 0 to 642.55 ms
 Type: Measured
 Suspect Parameter Number: 1447
 Parameter Group Number: [65147]

spn1448 - Cylinder 5 Combustion Time - The amount of time from when the ignition of the fuel is initiated to when the fuel is completely ignited (i.e., the flame front has propagated across the cylinder).

Data Length: 2 bytes
 Resolution: 0.01 ms/bit , 0 offset
 Data Range: 0 to 642.55 ms
 Type: Measured
 Suspect Parameter Number: 1448
 Parameter Group Number: [65148]

spn1449 - Cylinder 6 Combustion Time - The amount of time from when the ignition of the fuel is initiated to when the fuel is completely ignited (i.e., the flame front has propagated across the cylinder).

Data Length: 2 bytes
 Resolution: 0.01 ms/bit , 0 offset
 Data Range: 0 to 642.55 ms
 Type: Measured
 Suspect Parameter Number: 1449
 Parameter Group Number: [65148]

spn1450 - Cylinder 7 Combustion Time - The amount of time from when the ignition of the fuel is initiated to when the fuel is completely ignited (i.e., the flame front has propagated across the cylinder).

Data Length: 2 bytes
 Resolution: 0.01 ms/bit , 0 offset
 Data Range: 0 to 642.55 ms
 Type: Measured
 Suspect Parameter Number: 1450
 Parameter Group Number: [65148]

spn1451 - Cylinder 8 Combustion Time - The amount of time from when the ignition of the fuel is initiated to when the fuel is completely ignited (i.e., the flame front has propagated across the cylinder).

Data Length: 2 bytes
 Resolution: 0.01 ms/bit , 0 offset
 Data Range: 0 to 642.55 ms

Type: Measured
 Suspect Parameter Number: 1451
 Parameter Group Number: [65148]

spn1452 - Cylinder 9 Combustion Time - The amount of time from when the ignition of the fuel is initiated to when the fuel is completely ignited (i.e., the flame front has propagated across the cylinder).

Data Length: 2 bytes
 Resolution: 0.01 ms/bit , 0 offset
 Data Range: 0 to 642.55 ms
 Type: Measured
 Suspect Parameter Number: 1452
 Parameter Group Number: [65149]

spn1453 - Cylinder 10 Combustion Time - The amount of time from when the ignition of the fuel is initiated to when the fuel is completely ignited (i.e., the flame front has propagated across the cylinder).

Data Length: 2 bytes
 Resolution: 0.01 ms/bit , 0 offset
 Data Range: 0 to 642.55 ms
 Type: Measured
 Suspect Parameter Number: 1453
 Parameter Group Number: [65149]

spn1454 - Cylinder 11 Combustion Time - The amount of time from when the ignition of the fuel is initiated to when the fuel is completely ignited (i.e., the flame front has propagated across the cylinder).

Data Length: 2 bytes
 Resolution: 0.01 ms/bit , 0 offset
 Data Range: 0 to 642.55 ms
 Type: Measured
 Suspect Parameter Number: 1454
 Parameter Group Number: [65149]

spn1455 - Cylinder 12 Combustion Time - The amount of time from when the ignition of the fuel is initiated to when the fuel is completely ignited (i.e., the flame front has propagated across the cylinder).

Data Length: 2 bytes
 Resolution: 0.01 ms/bit , 0 offset
 Data Range: 0 to 642.55 ms
 Type: Measured
 Suspect Parameter Number: 1455
 Parameter Group Number: [65149]

spn1456 - Cylinder 13 Combustion Time - The amount of time from when the ignition of the fuel is initiated to when the fuel is completely ignited (i.e., the flame front has propagated across the cylinder).

Data Length: 2 bytes
 Resolution: 0.01 ms/bit , 0 offset

Data Range: 0 to 642.55 ms
 Type: Measured
 Suspect Parameter Number: 1456
 Parameter Group Number: [65150]

spn1457 - Cylinder 14 Combustion Time - The amount of time from when the ignition of the fuel is initiated to when the fuel is completely ignited (i.e., the flame front has propagated across the cylinder).

Data Length: 2 bytes
 Resolution: 0.01 ms/bit , 0 offset
 Data Range: 0 to 642.55 ms
 Type: Measured
 Suspect Parameter Number: 1457
 Parameter Group Number: [65150]

spn1458 - Cylinder 15 Combustion Time - The amount of time from when the ignition of the fuel is initiated to when the fuel is completely ignited (i.e., the flame front has propagated across the cylinder).

Data Length: 2 bytes
 Resolution: 0.01 ms/bit , 0 offset
 Data Range: 0 to 642.55 ms
 Type: Measured
 Suspect Parameter Number: 1458
 Parameter Group Number: [65150]

spn1459 - Cylinder 16 Combustion Time - The amount of time from when the ignition of the fuel is initiated to when the fuel is completely ignited (i.e., the flame front has propagated across the cylinder).

Data Length: 2 bytes
 Resolution: 0.01 ms/bit , 0 offset
 Data Range: 0 to 642.55 ms
 Type: Measured
 Suspect Parameter Number: 1459
 Parameter Group Number: [65150]

spn1460 - Cylinder 17 Combustion Time - The amount of time from when the ignition of the fuel is initiated to when the fuel is completely ignited (i.e., the flame front has propagated across the cylinder).

Data Length: 2 bytes
 Resolution: 0.01 ms/bit , 0 offset
 Data Range: 0 to 642.55 ms
 Type: Measured
 Suspect Parameter Number: 1460
 Parameter Group Number: [65151]

spn1461 - Cylinder 18 Combustion Time - The amount of time from when the ignition of the fuel is initiated to when the fuel is completely ignited (i.e., the flame front has propagated across the cylinder).

Data Length: 2 bytes

Resolution: 0.01 ms/bit , 0 offset
 Data Range: 0 to 642.55 ms
 Type: Measured
 Suspect Parameter Number: 1461
 Parameter Group Number: [65151]

spn1462 - Cylinder 19 Combustion Time - The amount of time from when the ignition of the fuel is initiated to when the fuel is completely ignited (i.e., the flame front has propagated across the cylinder).

Data Length: 2 bytes
 Resolution: 0.01 ms/bit , 0 offset
 Data Range: 0 to 642.55 ms
 Type: Measured
 Suspect Parameter Number: 1462
 Parameter Group Number: [65151]

spn1463 - Cylinder 20 Combustion Time - The amount of time from when the ignition of the fuel is initiated to when the fuel is completely ignited (i.e., the flame front has propagated across the cylinder).

Data Length: 2 bytes
 Resolution: 0.01 ms/bit , 0 offset
 Data Range: 0 to 642.55 ms
 Type: Measured
 Suspect Parameter Number: 1463
 Parameter Group Number: [65151]

spn1464 - Desired Combustion Time - The desired combustion time based upon engine load and speed lookup maps.

Data Length: 2 bytes
 Resolution: 0.01 ms/bit , 0 offset
 Data Range: 0 to 642.55 ms
 Type: Measured
 Suspect Parameter Number: 1464
 Parameter Group Number: [65152]

spn1465 - Average Engine Combustion Time - The average combustion time of all cylinders of an engine.

Data Length: 2 bytes
 Resolution: 0.01 ms/bit , 0 offset
 Data Range: 0 to 642.55 ms
 Type: Measured
 Suspect Parameter Number: 1465
 Parameter Group Number: [65152]

spn1466 - Steer Channel Mode - Indicates the functional mode of steer channel of the tire pressure control system.

0000 Maintain
 0001 Inflate
 0010 Deflate
 0011 Confirm
 0100 Inflate Wait ' System will inflate when conditions allow

0101 Deflate Wait ' System will deflate when conditions allow
 0110 Pressure Check
 0111-1101 Reserved
 1110 Error Condition
 1111 Not available

Bit Length: 4 bits
 Type: Status
 Suspect Parameter Number: 1466
 Parameter Group Number: [65144]

spn1467 - Trailer/tag Channel Mode - Indicates the functional mode of trailer/tag channel of the tire pressure control system.

0000 Maintain
 0001 Inflate
 0010 Deflate
 0011 Confirm
 0100 Inflate Wait ' System will inflate when conditions allow
 0101 Deflate Wait ' System will deflate when conditions allow
 0110 Pressure Check
 0111-1101 Reserved
 1110 Error Condition
 1111 Not available

Bit Length: 4 bits
 Type: Status
 Suspect Parameter Number: 1467
 Parameter Group Number: [65144]

spn1468 - Drive Channel Mode - Indicates the functional mode of trailer/tag channel of the tire pressure control system.

0000 Maintain
 0001 Inflate
 0010 Deflate
 0011 Confirm
 0100 Inflate Wait ' System will inflate when conditions allow
 0101 Deflate Wait ' System will deflate when conditions allow
 0110 Pressure Check
 0111-1101 Reserved
 1110 Error Condition
 1111 Not available

Bit Length: 4 bits
 Type: Status
 Suspect Parameter Number: 1468
 Parameter Group Number: [65144]

spn1469 - PCU Drive Solenoid Status - Current state of the drive solenoid used to implement a tire pressure control system in its pneumatic control unit (PCU).

00 - Off
 01 - On

Bit Length: 2 bits
 Type: Status
 Suspect Parameter Number: 1469
 Parameter Group Number: [65144]

spn1470 - PCU Steer Solenoid Status - Current state of the steer solenoid used to implement a tire pressure control system in its pneumatic control unit (PCU).

00 - Off
01 - On

Bit Length: 2 bits
Type: Status
Suspect Parameter Number: 1470
Parameter Group Number: [65144]

spn1471 - Tire Pressure Supply Switch Status - Current state of an open/closed type switch used to determine if adequate pressure exists for system implementation.

00 - Off
01 - On

Bit Length: 2 bits
Type: Status
Suspect Parameter Number: 1471
Parameter Group Number: [65144]

spn1472 - PCU Deflate Solenoid Status - Current state of the deflate solenoid used to implement a tire pressure control system in its pneumatic control unit (PCU).

00 - Off
01 - On

Bit Length: 2 bits
Type: Status
Suspect Parameter Number: 1472
Parameter Group Number: [65144]

spn1473 - PCU Control Solenoid Status - Current state of the control solenoid used to implement a tire pressure control system in its pneumatic control unit (PCU).

00 - Off
01 - On

Bit Length: 2 bits
Type: Status
Suspect Parameter Number: 1473
Parameter Group Number: [65144]

spn1474 - PCU Supply Solenoid Status - Current state of the supply solenoid used to implement a tire pressure control system in its pneumatic control unit (PCU).

00 - Off
01 - On

Bit Length: 2 bits
Type: Status
Suspect Parameter Number: 1474
Parameter Group Number: [65144]

spn1475 - PCU Trailer, Tag or Push Solenoid Status - Current state of the trailer, tag, or push solenoid used to implement a tire pressure control system in its pneumatic control unit (PCU).

00 - Off
01 - On

Bit Length: 2 bits

Type: Status
 Suspect Parameter Number: 1475
 Parameter Group Number: [65144]

spn1476 - Engine Oil Specific Resistance - Engine oil specific resistance used to describe the engine oil quality.

Data Length: 1 byte
 Resolution: 0.1 Mohm*m/bit , 0 offset
 Data Range: 0 to 25 Mohm*m
 Type: Measured
 Suspect Parameter Number: 1476
 Parameter Group Number: []

spn1477 - Engine Oil Kinematic Viscosity - Engine oil kinematic viscosity used to describe the engine oil quality.

Data Length: 1 byte
 Resolution: 1 mm²/s per bit , 0 offset
 Data Range: 0 to 250 mm²/s
 Type: Measured
 Suspect Parameter Number: 1477
 Parameter Group Number: []

spn1478 - Engine Oil Relative Dielectricity - Engine oil relative dielectricity used to describe the engine oil quality.

Data Length: 1 byte
 Resolution: 0.1/bit , 0 offset
 Data Range: 0 to 25.0
 Type: Measured
 Suspect Parameter Number: 1478
 Parameter Group Number: []

spn1480 - Source Address of Controlling Device for Retarder Control - The source address of the SAE J1939 device currently controlling the retarder. It is used to expand the torque mode parameter (see SPN 899) in cases where control is in response to an ECU that is not listed in Table SPN899_A. Its value may be the source address of the ECU transmitting the message (which means that no external SAE J1939 message is providing the active command) or the source address of the SAE J1939 ECU that is currently providing the active command in a TSC1 (see PGN 0) or similar message. Note that if this parameter value is the same as the source address of the device transmitting it, the control may be due to a message on a non-SAE J1939 data link such as SAE J1922 or a proprietary link.

Data Length: 1 byte
 Resolution: 1 source address/bit , 0 offset
 Data Range: 0 to 255
 Operating Range: 0 to 253
 Type: Status
 Suspect Parameter Number: 1480
 Parameter Group Number: [61440]

spn1481 - Source Address of Controlling Device for Brake Control - The source address of the SAE J1939

device currently controlling the brake system. Its value may be the source address of the ECU transmitting the message (which means that no external SAE J1939 message is providing the active command) or the source address of the SAE J1939 ECU that is currently providing the active command in a TSC1 (see PGN 0) or similar message. Note that if this parameter value is the same as the source address of the device transmitting it, the control may be due to a message on a non-SAE J1939 data link such as SAE J1922 or a proprietary link.

Data Length:	1 byte
Resolution:	1 source address/bit , 0 offset
Data Range:	0 to 255
Operating Range:	0 to 253
Type:	Status
Suspect Parameter Number:	1481
Parameter Group Number:	[61441]

spn1482 - Source Address of Controlling Device for Transmission Control - The source address of the SAE J1939 device currently controlling the transmission. Its value may be the source address of the ECU transmitting the message (which means that no external SAE J1939 message is providing the active command) or the source address of the SAE J1939 ECU that is currently providing the active command in a TSC1 (see PGN 0) or similar message. Note that if this parameter value is the same as the source address of the device transmitting it, the control may be due to a message on a non-SAE J1939 data link such as SAE J1922 or a proprietary link.

Data Length:	1 byte
Resolution:	1 source address/bit , 0 offset
Data Range:	0 to 255
Operating Range:	0 to 253
Type:	Status
Suspect Parameter Number:	1482
Parameter Group Number:	[61442]

spn1483 - Source Address of Controlling Device for Engine Control - The source address of the SAE J1939 device currently controlling the engine. It is used to expand the torque mode parameter (see SPN 899) in cases where control is in response to an ECU that is not listed in Table SPN899_A. Its value may be the source address of the ECU transmitting the message (which means that no external SAE J1939 message is providing the active command) or the source address of the SAE J1939 ECU that is currently providing the active command in a TSC1 (see PGN 0) or similar message. Note that if this parameter value is the same as the source address of the device transmitting it, the control may be due to a message on a non-J1939 data link such as SAE J1922 or a proprietary link.

Data Length:	1 byte
Resolution:	1 source address/bit , 0 offset
Data Range:	0 to 255
Operating Range:	0 to 253
Type:	Status
Suspect Parameter Number:	1483
Parameter Group Number:	[61444]

spn1487 - Illumination Brightness Percent - Commanded backlight brightness level for all cab displays

Data Length:	1 byte
Resolution:	0.4 %/bit , 0 offset

Data Range: 0 to 100 %
 Type: Status
 Suspect Parameter Number: 1487
 Parameter Group Number: [53248]

spn1504 - Operator Seat Switch - This switch senses the presence of the operator in the seat.
 This switch senses the presence of the operator in the seat.

Bit Length: 2 bits
 Type: ????
 Suspect Parameter Number: 1504
 Parameter Group Number: []

spn1573 - LED Display Data #1 - Informs display devices how to display the current vertical position.

00000010 High Coarse LED on
 00000100 High Fine LED on
 00001000 On-grade LED on
 00010000 Low Fine LED on
 00100000 Low Coarse LED on
 All other values Reserved

Bit Length: 8 bits
 Type: Status
 Suspect Parameter Number: 1573
 Parameter Group Number: [65142]

spn1574 - Laser Strike Vertical Deviation - The calculated distance from the laser strike position to the current land leveling system reference point.

Data Length: 2 bytes
 Resolution: 0.1 mm/bit , -3,200 mm offset
 Data Range: -3,200 to 3,225.5 mm
 Operating Range: -3200 to +3200 mm, negative values are below grade, positive values are above grade, zero is on grade, 0xFE03 indicates sensor can not sense the laser
 Type: Measured
 Suspect Parameter Number: 1574
 Parameter Group Number: [65141]

spn1575 - Modify Set Point - Used to control and coordinate the set point for the leveling system. Operating Range: -3200 to +3200 mm, negative values are below current position, positive values are above current position, zero is no change. Parameter specific parameter: 0xFE01 indicates Stop modifying the set point 0xFE03 indicates Raise the current set point by 5 mm 0xFE11 indicates Lower the current set point by 5 mm 0xFE13 indicates Search for laser or target 0xFE15 indicates go to the Park position 0xFE17 indicates go to the Bench position

Data Length: 2 bytes
 Resolution: 0.1 mm/bit , -3,200 mm offset
 Data Range: -3,200 to 3,225.5 mm
 Type: Measured
 Suspect Parameter Number: 1575
 Parameter Group Number: [65140]

spn1576 - Mast Position - Used to monitor the position of the sensor attached to the land leveling mast.

Data Length: 2 bytes
 Resolution: 0.1 mm/bit , -3,200 mm offset
 Data Range: -3,200 to 3,225.5 mm
 Operating Range: -3200 to +3200 mm, negative values are below current position, positive values are above current position, zero is no change
 Type: Measured
 Suspect Parameter Number: 1576
 Parameter Group Number: [65139]

spn1577 - Blade Duration and Direction - Used to indicate the duration and direction that the land leveling system blade moves.

Data Length: 2 bytes
 Resolution: 0.1 sec/bit , -3,276.8 sec offset
 Data Range: -3276.8 to 3148.7 sec
 Operating Range: -3276.8 to 3276.8 sec, negative values indicate move the blade up, positive values indicate move the blade down, zero indicates change
 Type: Status
 Suspect Parameter Number: 1577
 Parameter Group Number: [65138]

spn1578 - Blade Control Mode - Allows the user to select the type of blade control for the land leveling system.

- 00000000 Manual mode
- 00000001 Automatic mode
- 00000010 Inactive automatic mode
- All other values Reserved

Bit Length: 8 bits
 Type: Status
 Suspect Parameter Number: 1578
 Parameter Group Number: [65138]

spn1579 - Laser Tracer Target Deviation - The calculated distance for the laser target to the current laser tracer reference point. Parameter specific parameter: 0xFE03 indicates that the sensor can not sense the laser

Data Length: 2 bytes
 Resolution: 0.1 mm/bit , -3,200 mm offset
 Data Range: -3,200 to 3,225.5 mm
 Operating Range: -3200 to +3200 mm, negative values are below setpoint, positive values are above setpoint, zero is on grade.
 Type: Measured
 Suspect Parameter Number: 1579
 Parameter Group Number: [65137]

spn1580 - Laser Tracer Vertical Distance - The elevation of the laser tracer sensor in a laser leveling system.

Data Length: 2 bytes
 Resolution: 0.1 mm/bit , 0 offset
 Data Range: 0 to 6,425.5 mm
 Operating Range: 0 to 6400 mm

Type: Measured
 Suspect Parameter Number: 1580
 Parameter Group Number: [65137]

spn1581 - Laser Tracer Horizontal Deviation - The calculated percent deviation between the target distance and the center of the laser tracer.

Data Length: 1 byte
 Resolution: 1 %/bit , 0 offset
 Data Range: 0 to 250 %
 Operating Range: 0 to 200%, 0 to 99% indicates target is left of center, 101 to 200% indicates target is right of center, 100% indicates target centered, 0xFF indicates previous pass mode and thus no horizontal deviation
 Type: Measured
 Suspect Parameter Number: 1581
 Parameter Group Number: [65137]

spn1582 - LED Display Data #2 - Informs display devices how to display the current position of the laser tracer.

00000001 On-grade 'A' LED on
 00000010 On-grade 'B' LED on
 00000100 On-grade 'C' LED on
 00001000 Up LED on
 00010000 Down LED on
 00100000 Left LED on
 01000000 Right LED on
 All other values Reserved

Bit Length: 8 bits
 Type: Status
 Suspect Parameter Number: 1582
 Parameter Group Number: [65137]

spn1583 - Laser Tracer Information - Provides the status of the laser tracer to the operator.

00000001 Laser power is on
 00000010 Laser is ready
 00000100 Valid target (1 = yes)
 00001000 Previous pass (1 = yes)
 00010000 Stringline (1 = yes)
 00100000 Curb (1 = yes)
 All other values Reserved

Bit Length: 8 bits
 Type: Status
 Suspect Parameter Number: 1583
 Parameter Group Number: [65137]

spn1584 - Service Component Identification - Identification of component needing service. See Table SPN911_A.

Data Length: 1 byte
 Resolution: 1 ID/bit , 0 offset
 Data Range: 0 to 250 ID
 Type: Measured
 Suspect Parameter Number: 1584
 Parameter Group Number: [56832]

spn1585 - Powered Vehicle Weight - Total mass imposed by the tires of the powered vehicle on the road surface. Does not include the trailer.

Data Length:	2 bytes
Resolution:	10 kg/bit , 0 offset
Data Range:	0 to 642,550 kg
Type:	Measured
Suspect Parameter Number:	1585
Parameter Group Number:	[65136]

spn1586 - Speed of forward vehicle - Absolute velocity of the preceding vehicle situated within 250 m in the same lane and moving in the same direction.

Data Length:	1 byte
Resolution:	1 km/h per bit , 0 offset
Data Range:	0 to 250 km/h
Operating Range:	0xFF = no vehicle detected
Type:	Measured
Suspect Parameter Number:	1586
Parameter Group Number:	[65135]

spn1587 - Distance to forward vehicle - Distance to the preceding vehicle situated within 250 m in the same lane and moving in the same direction.

Data Length:	1 byte
Resolution:	1 m/bit , 0 offset
Data Range:	0 to 250 m
Operating Range:	0xFF = no vehicle detected
Type:	Measured
Suspect Parameter Number:	1587
Parameter Group Number:	[65135]

spn1588 - Adaptive Cruise Control Set Speed - Value of the desired (chosen) velocity of the adaptive cruise control system.

Data Length:	1 byte
Resolution:	1 km/h per bit , 0 offset
Data Range:	0 to 250 km/h
Operating Range:	0 to 120 km/h
Type:	Status
Suspect Parameter Number:	1588
Parameter Group Number:	[65135]

spn1589 - Adaptive cruise control set distance mode - Selected distance mode for adaptive cruise control.

- 000 ACC Distance mode #1 (largest distance)
- 001 ACC Distance mode #2
- 010 ACC Distance mode #3
- 011 ACC Distance mode #4
- 100 ACC Distance mode #5 (shortest distance)
- 101 Conventional cruise control mode
- 110 Error condition

111 Not available/not valid

Bit Length: 3 bits
 Type: Status
 Suspect Parameter Number: 1589
 Parameter Group Number: [65135]

spn1590 - Adaptive Cruise Control Mode - This parameter is used to indicate the current state, or mode, of operation by the Adaptive Cruise Control (ACC) device. The states characterize independent system states (e.g., it is not possible to express distance control active and overtake mode simultaneously). ACC must not switch itself off while active because the driver expects it to work. So if an error occurs, the ACC must signal that to the driver so that the driver knows that he has to switch off the ACC.

000 Off (Standby, enabled, ready for activation)

001 Speed control active

010 Distance control active

011 Overtake mode

100 Hold mode

101 Finish mode

110 Disabled or error condition

111 Not available/not valid

000b - Off'Used to indicate the ACC is enabled in calibration or configuration and there are no faults that would prevent the system from operating.

001b - Speed Control Active'Used to indicate that ACC is on but not currently sending control messages. In other words, there is no target ahead and regular vehicle cruise control is controlling the vehicle speed to the driver's set speed.

010b - Distance Control Active'Used to indicate that ACC is on and actively sending control messages to maintain the appropriate following interval.

011b - Overtake Mode'Used to indicate that ACC is on but temporarily disabled because the driver is manually overriding cruise control by using either the accelerator pedal or the cruise control 'accel' switch.

100b - Hold Mode'Used to indicate that the ACC has lost the previous target vehicle and is in HOLD mode. In this mode, the ACC shall limit the speed to the speed held when the target was lost. For example, if the driver activates the typical cruise buttons (Resume/Inc/Dec) the HOLD mode shall be exited and normal cruise functionality resumed. If a new target is detected, the Distance Control Active mode (010b) is again entered, unless existing conditions prohibit this.

101b - Finish Mode'Used to indicate that ACC is on with no target ahead, and ACC is currently sending control messages to return to the driver's set speed. This occurs when the target the ACC system was tracking moves out of the way so ACC returns the vehicle to the driver's set speed.

110b - Disabled or Error Condition'Used to indicate that ACC is in an error state and can not operate.

Bit Length: 3 bits
 Type: Status
 Suspect Parameter Number: 1590
 Parameter Group Number: [65135]

spn1591 - Road curvature - Estimated value of the current road curvature for use by the adaptive cruise control system.

Positive values are used for left curves. Curvature is the inverse of the radius and is zero for straight roads.

Data Length: 2 bytes
 Resolution: 1/128 1/km per bit , -250 1/km offset
 Data Range: -250 to 251.992 1/km
 Type: Status
 Suspect Parameter Number: 1591
 Parameter Group Number: [65135]

spn1592 - Front Axle, Left Wheel Speed - High resolution measurement of the speed of the left wheel on the front axle.

Data Length: 2 bytes
 Resolution: 1/256 km/h per bit , 0 offset
 Data Range: 0 to 250.996 km/h
 Type: Measured
 Suspect Parameter Number: 1592

Parameter Group Number: [65134]

spn1593 - Front axle, right wheel speed - High resolution measurement of the speed of the right wheel on the front axle.

Data Length: 2 bytes
 Resolution: 1/256 km/h per bit , 0 offset
 Data Range: 0 to 250.996 km/h
 Type: Measured
 Suspect Parameter Number: 1593
 Parameter Group Number: [65134]

spn1594 - Rear axle, left wheel speed - High resolution measurement of the speed of the left wheel on the rear axle.

Data Length: 2 bytes
 Resolution: 1/256 km/h per bit , 0 offset
 Data Range: 0 to 250.996 km/h
 Type: Measured
 Suspect Parameter Number: 1594
 Parameter Group Number: [65134]

spn1595 - Rear axle, right wheel speed - High resolution measurement of the speed of the right wheel on the rear axle.

Data Length: 2 bytes
 Resolution: 1/256 km/h per bit , 0 offset
 Data Range: 0 to 250.996 km/h
 Type: Measured
 Suspect Parameter Number: 1595
 Parameter Group Number: [65134]

spn1601 - Local minute offset - Local offset in minutes from a reference time.

Data Length: 1 byte
 Resolution: 1 min/bit , -125 mins offset
 Data Range: -125 to 125 mins
 Operating Range: -59 to +59 min
 Type: Measured
 Suspect Parameter Number: 1601
 Parameter Group Number: [65254]

spn1602 - Local hour offset - Local offset in hours from a reference time

Data Length: 1 byte
 Resolution: 1 hr/bit , -125 hr offset
 Data Range: -125 to 125 hr
 Operating Range: -24 to +23 h
 Type: Measured
 Suspect Parameter Number: 1602
 Parameter Group Number: [65254]

spn1603 - Adjust seconds - Part of the parameter used to set the time.

Data Length:	1 byte
Resolution:	0.25 s/bit , 0 offset
Data Range:	0 to 62.5 s
Operating Range:	0 to 59.75 s
Type:	Measured
Suspect Parameter Number:	1603
Parameter Group Number:	[54528]

spn1604 - Adjust minutes - Part of the parameter used to set the time.

Data Length:	1 byte
Resolution:	1 min/bit , 0 offset
Data Range:	0 to 250 mins
Operating Range:	0 to 59 min
Type:	Measured
Suspect Parameter Number:	1604
Parameter Group Number:	[54528]

spn1605 - Adjust hours - Part of the parameter used to set the time.

Data Length:	1 byte
Resolution:	1 hr/bit , 0 offset
Data Range:	0 to 250 hr
Operating Range:	0 to 23 h
Type:	Measured
Suspect Parameter Number:	1605
Parameter Group Number:	[54528]

spn1606 - Adjust month - Part of a parameter used to set a calendar date. NOTE - A value of 0 for the month is null. The value 1 identifies January; 2 identifies February; etc.

Data Length:	1 byte
Resolution:	1 month/bit , 0 offset
Data Range:	0 to 250 months
Operating Range:	1 to 12 month
Type:	Measured
Suspect Parameter Number:	1606
Parameter Group Number:	[54528]

spn1607 - Adjust day - Part of a parameter used to set a calendar date. NOTE - A value of 0 for the date is null. The values 1, 2, 3, and 4 are used to identify the first day of the month; 5, 6, 7, and 8 identify the second day of the month; etc.

Data Length:	1 byte
Resolution:	0.25 days/bit , 0 offset
Data Range:	0 to 62.5 days
Operating Range:	0.25 to 31.75 day
Type:	Measured

Suspect Parameter Number: 1607
 Parameter Group Number: [54528]

spn1608 - Adjust year - Part of a parameter used to set a calendar date. NOTE - A value of 0 for the year identifies the year 1985; a value of 1 identifies 1986; etc.

Data Length: 1 byte
 Resolution: 1 year/bit , 1985 years offset
 Data Range: 1985 to 2235 years
 Operating Range: 1985 to 2235 year
 Type: Measured
 Suspect Parameter Number: 1608
 Parameter Group Number: [54528]

spn1609 - Adjust local minute offset - Used to set the local offset in minutes from a reference time.

Data Length: 1 byte
 Resolution: 1 min/bit , -125 mins offset
 Data Range: -125 to 125 mins
 Operating Range: -59 to +59 min
 Type: Measured
 Suspect Parameter Number: 1609
 Parameter Group Number: [54528]

spn1610 - Adjust local hour offset - Used to set the local offset in hours from a reference time

Data Length: 1 byte
 Resolution: 1 hr/bit , -125 hr offset
 Data Range: -125 to 125 hr
 Operating Range: -24 to +23 h
 Type: Measured
 Suspect Parameter Number: 1610
 Parameter Group Number: [54528]

spn1611 - Drive recognize - Indicates whether motion of the vehicle is detected or not.

- 00 Vehicle motion not detected
- 01 Vehicle motion detected

Bit Length: 2 bits
 Type: Measured
 Suspect Parameter Number: 1611
 Parameter Group Number: [65132]

spn1612 - Driver 1 working state - State of work of the driver.

- 000 Rest - sleeping
- 001 Driver available ' short break
- 010 Work ' loading, unloading, working in an office
- 011 Drive ' behind wheel
- 100-101 Reserved
- 110 Error
- 111 Not available

Bit Length: 3 bits
 Type: Status
 Suspect Parameter Number: 1612
 Parameter Group Number: [65132]

spn1613 - Driver 2 working state - State of work of the driver.

- 000 Rest - sleeping
- 001 Driver available ' short break
- 010 Work ' loading, unloading, working in an office
- 011 Drive ' behind wheel
- 100-101 Reserved
- 110 Error
- 111 Not available

Bit Length: 3 bits
 Type: Status
 Suspect Parameter Number: 1613
 Parameter Group Number: [65132]

spn1614 - Overspeed - Indicates whether the vehicle is exceeding the legal speed limit set in the tachograph.

- 00 No overspeed
- 01 Overspeed

Bit Length: 2 bits
 Type: Measured
 Suspect Parameter Number: 1614
 Parameter Group Number: [65132]

spn1615 - Driver card, driver 1 - Indicates the presence of a driver card

- 00 - Driver card not present
- 01 - Driver card present

Bit Length: 2 bits
 Type: Measured
 Suspect Parameter Number: 1615
 Parameter Group Number: [65132]

spn1616 - Driver card, driver 2 - Indicates the presence of a driver card

- 00 - Driver card not present
- 01 - Driver card present

Bit Length: 2 bits
 Type: Measured
 Suspect Parameter Number: 1616
 Parameter Group Number: [65132]

spn1617 - Driver 1 Time Related States - Indicates if the driver approaches or exceeds working time limits (or other limits).

- 0000 Normal/No limits reached
- 0001 Limit #1 ' 15 min before 4 ½ h
- 0010 Limit #2 ' 4 ½ h reached
- 0011 Limit #3 ' 15 min before 9 h
- 0100 Limit #4 ' 9 h reached
- 0101 Limit #5 ' 15 min before 16 h (not having 8h rest during the last 24h)
- 0110 Limit #6 ' 16 h reached
- 0111-1100 Reserved

1101 Other
 1110 Error
 1111 Not available

Bit Length: 4 bits
 Type: Measured
 Suspect Parameter Number: 1617
 Parameter Group Number: [65132]

spn1618 - Driver 2 Time Related States - Indicates if the driver approaches or exceeds working time limits (or other limits).

0000 Normal/No limits reached
 0001 Limit #1 ' 15 min before 4 ½ h
 0010 Limit #2 ' 4 ½ h reached
 0011 Limit #3 ' 15 min before 9 h
 0100 Limit #4 ' 9 h reached
 0101 Limit #5 ' 15 min before 16 h (not having 8h rest during the last 24h)
 0110 Limit #6 ' 16 h reached
 0111-1100 Reserved
 1101 Other
 1110 Error
 1111 Not available

Bit Length: 4 bits
 Type: Measured
 Suspect Parameter Number: 1618
 Parameter Group Number: [65132]

spn1619 - Direction indicator - Indicates the direction of the vehicle.

00 - Forward
 01 - Reverse

Bit Length: 2 bits
 Type: Measured
 Suspect Parameter Number: 1619
 Parameter Group Number: [65132]

spn1620 - Tachograph performance - Indicates the tachograph performance; including electronic or mechanical analysis, instrument analysis, speed sensor analysis, mass storage analysis, and printer analysis.

00 - Normal performance
 01 - Performance analysis

Bit Length: 2 bits
 Type: Status
 Suspect Parameter Number: 1620
 Parameter Group Number: [65132]

spn1621 - Handling information - Indicates that handling information is present. Information could include 'no printer paper', 'no driver card', etc.

00 - No handling information
 01 - Handling information

Bit Length: 2 bits
 Type: Status
 Suspect Parameter Number: 1621
 Parameter Group Number: [65132]

spn1622 - System event - Indicates that a tachograph event has occurred. This may include power supply interruption, interruption of the speed sensor, incorrect data on the driver card, driving without a driver card, illegal removal of a driver card, insertion of a driver card during driving, and time adjustment.

- 00 - No tachograph event
- 01 - Tachograph event

Bit Length: 2 bits
 Type: Status
 Suspect Parameter Number: 1622
 Parameter Group Number: [65132]

spn1623 - Tachograph output shaft speed - Calculated speed of the transmission output shaft.

Data Length: 2 bytes
 Resolution: 0.125 rpm/bit , 0 offset
 Data Range: 0 to 8,031.875 rpm
 Type: Measured
 Suspect Parameter Number: 1623
 Parameter Group Number: [65132]

spn1624 - Tachograph vehicle speed - Speed of the vehicle registered by the tachograph.

Data Length: 2 bytes
 Resolution: 1/256 km/h per bit , 0 offset
 Data Range: 0 to 250.996 km/h
 Type: Measured
 Suspect Parameter Number: 1624
 Parameter Group Number: [65132]

spn1625 - Driver 1 identification - Used to obtain the driver identity.

Data Length: Variable ("*" delimited)
 Resolution: ASCII , 0 offset
 Data Range: 0 to 255 per byte
 Type: Measured
 Suspect Parameter Number: 1625
 Parameter Group Number: [65131]

spn1626 - Driver 2 identification - Used to obtain the driver identity.

Data Length: Variable ("*" delimited)
 Resolution: ASCII , 0 offset
 Data Range: 0 to 255 per byte
 Type: Measured
 Suspect Parameter Number: 1626
 Parameter Group Number: [65131]

spn1632 - Torque Limit Feature - Torque limit rating described in the current record.

- 000 Reserved
- 001 Highest torque rating
- 010 First torque rating

011 Previous torque rating (rating prior to the current rating)
 100 Current torque rating
 101-110 Reserved
 111 Not available

Bit Length: 3 bits
 Type: Status
 Suspect Parameter Number: 1632
 Parameter Group Number: [65168]

spn1633 - Cruise Control Pause Switch - Switch signal which indicates the position of the Cruise Control Pause Switch used on Remote Cruise Control applications. The Cruise Control Pause Switch signal temporarily disables the Cruise Control function.

00 - Off
 01 - On
 10 - Error Indicator
 11 -Take No Action

Bit Length: 2 bits
 Type: Measured
 Suspect Parameter Number: 1633
 Parameter Group Number: [65265]

spn1636 - Intake Manifold 1 Air Temperature (High Resolution) - Temperature of pre-combustion air found in intake manifold of engine air supply system. The higher resolution is required for control purposes.

Data Length: 2 bytes
 Resolution: 0.03125 deg C/bit , -273 deg C offset
 Data Range: -273 to 1735 deg C
 Type: Measured
 Suspect Parameter Number: 1636
 Parameter Group Number: [65129]

spn1637 - Engine Coolant Temperature (High Resolution) - Temperature of liquid found in engine cooling system. The higher resolution is required for control purposes.

Data Length: 2 bytes
 Resolution: 0.03125 deg C/bit , -273 deg C offset
 Data Range: -273 to 1735 deg C
 Type: Measured
 Suspect Parameter Number: 1637
 Parameter Group Number: [65129]

spn1638 - Hydraulic Temperature - Temperature of hydraulic fluid.

Data Length: 1 byte
 Resolution: 1 deg C/bit , -40 deg C offset
 Data Range: -40 to 210 deg C
 Type: Measured
 Suspect Parameter Number: 1638
 Parameter Group Number: [65128]

spn1639 - Fan Speed - The speed of the fan associated with engine coolant system.

Data Length: 2 bytes
 Resolution: 0.125 rpm/bit , 0 offset
 Data Range: 0 to 8,031.875 rpm
 Type: Measured
 Suspect Parameter Number: 1639
 Parameter Group Number: [65213]

spn1653 - Vehicle Limiting Speed Governor Enable Switch - Switch signal which enables the Vehicle Limiting Speed Governor (VLSG) such that the vehicle speed may be either increased or decreased when the engine is off idle.
 Switch signal which enables the Vehicle Limiting Speed Governor (VLSG) such that the vehicle speed may be either increased or decreased when the engine is off idle.

Bit Length: 2 bits
 Type: Measured
 Suspect Parameter Number: 1653
 Parameter Group Number: [57344]

spn1654 - Vehicle Limiting Speed Governor Increment Switch - Switch signal which increases the Vehicle Limiting Speed Governor (VLSG).

Switch signal which increases the Vehicle Limiting Speed Governor (VLSG).

Bit Length: 2 bits
 Type: Measured
 Suspect Parameter Number: 1654
 Parameter Group Number: [57344]

spn1655 - Vehicle Limiting Speed Governor Decrement Switch - Switch signal which decreases the Vehicle Limiting Speed Governor (VLSG).

Switch signal which decreases the Vehicle Limiting Speed Governor (VLSG).

Bit Length: 2 bits
 Type: Measured
 Suspect Parameter Number: 1655
 Parameter Group Number: [57344]

spn1656 - Engine Automatic Start Enable Switch - Switch signal which enables the idle management system to be enabled. When this system is enabled with the engine in an idle mode and safe operating conditions existing, then the engine may be started or stopped automatically.

Switch signal which enables the idle management system to be enabled. When this system is enabled with the engine in an idle mode and safe operating conditions existing, then the engine may be started or stopped automatically.

Bit Length: 2 bits
 Type: Measured
 Suspect Parameter Number: 1656
 Parameter Group Number: [57344]

spn1665 - Turbo Oil Level Switch - Switch signal which indicates the presence of oil at the turbocharger

Switch signal which indicates the presence of oil at the turbocharger

Bit Length: 2 bits
 Type: Measured
 Suspect Parameter Number: 1665

Parameter Group Number: [65245]

spn1666 - Automatic Gear Shifting Enable Switch -

Bit Length: 2 bits
 Type: ????
 Suspect Parameter Number: 1666
 Parameter Group Number: [57344]

spn1667 - Retarder Requesting Brake Light -

Bit Length: 2 bits
 Type: ????
 Suspect Parameter Number: 1667
 Parameter Group Number: [61440]

spn1675 - Engine Starter Mode - There are several phases in a starting action and different reasons why a start cannot take place.

- 0000 start not requested
- 0001 starter active, gear not engaged
- 0010 starter active, gear engaged
- 0011 start finished; starter not active after having been actively engaged (after 50ms mode goes to 0000)
- 0100 starter inhibited due to engine already running
- 0101 starter inhibited due to engine not ready for start (preheating)
- 0110 starter inhibited due to driveline engaged or other transmission inhibit
- 0111 starter inhibited due to active immobilizer
- 1000 starter inhibited due to starter over-temp
- 1001-1011 Reserved
- 1100 starter inhibited - reason unknown
- 1101 error (legacy implementations only; use 1110)
- 1110 error
- 1111 not available

Bit Length: 4 bits
 Type: Status
 Suspect Parameter Number: 1675
 Parameter Group Number: [61444]

spn1676 - Auxiliary Heater Water Pump Status - Parameter indicating whether the auxiliary heater water pump is running

- 00 Water Pump is not running
- 01 Water Pump is running
- 10 Reserved
- 11 Not available

Bit Length: 2 bits
 Type: Status
 Suspect Parameter Number: 1676
 Parameter Group Number: [65133]

spn1677 - Auxiliary Heater Mode - State of the auxiliary heater

- 0000 Heater not active
- 0001 Off due to ADR per European Regulations for Transport of hazardous materials
- 0010 Economy mode
- 0011 Normal mode
- 0100-1101 Not defined
- 1110 Error

1111 Not available

Bit Length: 4 bits
 Type: Status
 Suspect Parameter Number: 1677
 Parameter Group Number: [65133]

spn1678 - Cab Ventilation - Indicates whether the cab is being ventilated or not.

00 Cab not ventilated
 01 Cab is ventilated
 10 Reserved
 11 Not available

Bit Length: 2 bits
 Type: Status
 Suspect Parameter Number: 1678
 Parameter Group Number: [65133]

spn1679 - Engine Heating Zone - Parameter indicating whether the engine zone is being heated.

00 Engine heating zone off
 01 Engine heating zone on
 10 Reserved
 11 Not available

Bit Length: 2 bits
 Type: Status
 Suspect Parameter Number: 1679
 Parameter Group Number: [65133]

spn1680 - Cab Heating Zone - Parameter indicating whether the cab zone is being heated.

00 Cab heating zone off
 01 Cab heating zone on
 10 Reserved
 11 Not available

Bit Length: 2 bits
 Type: Status
 Suspect Parameter Number: 1680
 Parameter Group Number: [65133]

spn1681 - Battery Main Switch Hold State - Parameter indicating whether the battery main switch is held due to an external request or not. The state battery main switch held indicates that the battery main switch is about to switch off.

00 Battery main switch not held
 01 Battery main switch held
 10 Reserved
 11 Don't care/take no action

Bit Length: 2 bits
 Type: Measured
 Suspect Parameter Number: 1681
 Parameter Group Number: [65126]

spn1682 - Battery Main Switch Hold Request - Request to hold the battery main switch.

00 Release Battery Main Switch
 01 Hold Battery Main Switch
 10 undefined
 11 Don't care/take no action

Bit Length: 2 bits
 Type: Status
 Suspect Parameter Number: 1682
 Parameter Group Number: [57344]

spn1683 - Auxiliary Heater Mode Request - Request to activate the auxiliary heater.

0000 De-activate auxiliary heater
 0001 Off due to ADR per European Regulations for Transport of hazardous materials
 0010 Economy mode
 0011 Normal mode
 0100-1101 Not defined
 1110 Reserved
 1111 Don't care/take no action

Bit Length: 4 bits
 Type: Status
 Suspect Parameter Number: 1683
 Parameter Group Number: [57344]

spn1684 - Auxiliary Heater Coolant Pump Request - Indicates whether to activate the auxiliary heater coolant water pump.

00 Deactivate water pump
 01 Activate water pump
 10 Reserved
 11 Don't care/take no action

Bit Length: 2 bits
 Type: Status
 Suspect Parameter Number: 1684
 Parameter Group Number: [57344]

spn1685 - Request Engine Zone Heating - Request to activate engine zone heating.

00 Do not heat engine zone
 01 Heat engine zone
 10 Reserved
 11 Don't care/take no action

Bit Length: 2 bits
 Type: Status
 Suspect Parameter Number: 1685
 Parameter Group Number: [57344]

spn1686 - Request Cab Zone Heating - Request to activate cab zone heating.

00 Do not cab engine zone
 01 Heat cab zone
 10 Reserved
 11 Don't care/take no action

Bit Length: 2 bits
 Type: Status
 Suspect Parameter Number: 1686
 Parameter Group Number: [57344]

spn1687 - Auxiliary Heater Output Coolant Temperature - Temperature of the auxiliary heater output coolant (I.e. water in a water heater system.)

Data Length: 1 byte
 Resolution: 1 deg C/bit , -40 deg C offset
 Data Range: -40 to 210 deg C
 Type: Measured
 Suspect Parameter Number: 1687
 Parameter Group Number: [65133]

spn1688 - Auxiliary Heater Input Air Temperature - Temperature of the input air in an auxiliary heater system.

Data Length: 1 byte
 Resolution: 1 deg C/bit , -40 deg C offset
 Data Range: -40 to 210 deg C
 Type: Measured
 Suspect Parameter Number: 1688
 Parameter Group Number: [65133]

spn1689 - Auxiliary Heater Output Power Percent - Current auxiliary heater output power, relative to the auxiliary heater maximum output power.

Data Length: 1 byte
 Resolution: 0.4 %/bit , 0 offset
 Data Range: 0 to 100 %
 Type: Measured
 Suspect Parameter Number: 1689
 Parameter Group Number: [65133]

spn1690 - Auxiliary Heater Maximum Output Power - The maximum output power of the auxiliary heater.

Data Length: 2 bytes
 Resolution: 2 W/bit , 0 offset
 Data Range: 0 to 128,510 W
 Type: Measured
 Suspect Parameter Number: 1690
 Parameter Group Number: [65127]

spn1691 - Cab Interior Temperature Command - Parameter used to command a certain cab interior temperature.

Note: See SPN 1662 and SPN 170.

Data Length: 2 bytes
 Resolution: 0.03125 deg C/bit , -273 deg C offset
 Data Range: -273 to 1735 deg C
 Type: Status
 Suspect Parameter Number: 1691
 Parameter Group Number: [57344]

spn1692 - Desired Absolute Intake Manifold Pressure (Turbo Boost Limit) - The desired absolute intake manifold pressure of the engine.

Data Length: 2 bytes

Resolution: 0.1 kPa/bit , 0 offset
 Data Range: 0 to 6,425.5 kPa
 Type: Status
 Suspect Parameter Number: 1692
 Parameter Group Number: [65194]

spn1693 - Wastegate Valve Position - The position of the turbocharger wastegate valve (not the electronic wastegate control valve).

Data Length: 1 byte
 Resolution: 0.4 %/bit , 0 offset
 Data Range: 0 to 100 %
 Type: Measured
 Suspect Parameter Number: 1693
 Parameter Group Number: [65194]

spn1694 - Gas Mass Flow Sensor Fueling Correction - The amount of fuel the Gas Mass Flow Sensor is sensing should be added or subtracted compared to the maximum amount of fuel the control system allows the sensor to add or subtract.

Data Length: 1 byte
 Resolution: 1 %/bit , -125% offset
 Data Range: -125 to 125 %
 Type: Measured
 Suspect Parameter Number: 1694
 Parameter Group Number: [65194]

spn1695 - Exhaust Gas Oxygen Sensor Fueling Correction - The amount of fueling change required by the system based on the measured Exhaust Oxygen value compared to the maximum fueling change permitted by the system, expressed as percentages.

Data Length: 1 byte
 Resolution: 1 %/bit , -125% offset
 Data Range: -125 to 125 %
 Type: Status
 Suspect Parameter Number: 1695
 Parameter Group Number: [65193]

spn1696 - Exhaust Gas Oxygen Sensor Closed Loop Operation - Indicates whether the engine is using the Exhaust Gas Oxygen sensor to control the air/fuel ratio.

- 00 Command to disable function
- 01 Command to enable function
- 10 Reserved
- 11 Don't Care/take no action

Bit Length: 2 bits
 Type: Status
 Suspect Parameter Number: 1696
 Parameter Group Number: [65193]

spn1697 - CTI Wheel End Electrical Fault - Indicates the status of electrical fault on CTI wheel interface.

00 Ok (No Fault)
 01 Not Defined
 10 Error
 11 Not Supported

Bit Length: 2 bits
 Type: Measured
 Suspect Parameter Number: 1697
 Parameter Group Number: [65268]

spn1698 - CTI Tire Status - Indicates the status of the tire.

00 Ok (no fault)
 01 Tire leak detected
 10 Error
 11 Not Supported

Bit Length: 2 bits
 Type: Measured
 Suspect Parameter Number: 1698
 Parameter Group Number: [65268]

spn1699 - CTI Wheel Sensor Status - Indicates whether the wheel is being monitored by the CTI controller.

00 Off / isolated from CTI Pressure Controller
 01 On (tire is polled)
 10 Not Defined
 11 Not Supported

Bit Length: 2 bits
 Type: Measured
 Suspect Parameter Number: 1699
 Parameter Group Number: [65268]

spn1700 - Lane Departure Imminent, Left Side - Indicates departure imminent on left side of lane.

00 Not imminent
 01 Imminent
 10 Reserved
 11 Not used

Bit Length: 2 bits
 Type: Status
 Suspect Parameter Number: 1700
 Parameter Group Number: [61447]

spn1701 - Lane Departure Imminent, Right Side - Indicates departure imminent on right side of lane.

00 Not imminent
 01 Imminent
 10 Reserved
 11 Not Used

Bit Length: 2 bits
 Type: Status
 Suspect Parameter Number: 1701
 Parameter Group Number: [61447]

spn1702 - Lane Departure Indication Enable Status - Indicates whether lane departure indication is active.

00 Lane Departure indication disabled
 01 Lane Departure Indication enabled

10 Reserved
11 Not Used

Bit Length: 2 bits
Type: Status
Suspect Parameter Number: 1702
Parameter Group Number: [65115]

spn1710 - Lane Tracking Status Left Side - Indicates whether the left side is tracking lane.

00 Not Tracking Left side
01 Tracking Left side
10 Reserved
11 Don't care/Take no action

Bit Length: 2 bits
Type: Status
Suspect Parameter Number: 1710
Parameter Group Number: [65115]

spn1711 - Lane Tracking Status Right Side - Indicates whether right side is tracking lane.

00 Not Tracking Right side
01 Tracking Right side
10 Reserved
11 Don't Care/take no action

Bit Length: 2 bits
Type: Status
Suspect Parameter Number: 1711
Parameter Group Number: [65115]

spn1712 - Extended Range Requested Speed Control Range Upper Limit (Engine configuration) -

The maximum engine speed regardless of load that the engine will allow when operating in a speed control/limit mode, excluding any maximum momentary engine override speed, if supported. When the limit is higher than 2500 RPM the 'Requested Speed Control Range Upper Limit (Engine Configuration)' parameter (see SPN 536) will be transmitted with a value of 2500 RPM.

Data Length: 2 bytes
Resolution: 0.125 rpm/bit , 0 offset
Data Range: 0 to 8,031.875 rpm
Type: Measured
Suspect Parameter Number: 1712
Parameter Group Number: [65251]

spn1713 - Hydraulic Oil Filter Restriction Switch - This switch indicates whether hydraulic oil filter is clogged.

00 No restriction
01 Restriction exists on oil filter
10 Error
11 Not Available

Bit Length: 2 bits
Type: Measured
Suspect Parameter Number: 1713
Parameter Group Number: [65128]

spn1714 - Operator Seat Direction Switch - Senses whether the operator seat is in the forward driving position

00 Operator seat not facing forward
 01 Operator seat is facing forward
 10 Error
 11 Not Available

Bit Length: 2 bits
 Type: Measured
 Suspect Parameter Number: 1714
 Parameter Group Number: [57344]

spn1715 - Drivers Demand Retarder - Percent Torque - The Drivers demand retarder ' percent torque is the maximum torque selected by the driver when one or more modes are selected by the driver, such as hand lever, switch, constant torque, constant velocity, etc.

Data Length: 1 byte
 Resolution: 1 %/bit , -125% offset
 Data Range: -125 to 125 %
 Operating Range: -125% to 0%
 Type: Status
 Suspect Parameter Number: 1715
 Parameter Group Number: [61440]

spn1716 - Retarder Selection, non-engine - The 'Retarder Selection, non-engine' is the position of the driver's selector for retarders that are not part of the engine system, expressed as percent and determined by the ratio of current position to the maximum possible position. The physical device may be a lever, rotary dial, combination of switches, or other device that the driver can use to select the type or amount of retardation needed.

Data Length: 1 byte
 Resolution: 0.4 %/bit , 0 offset
 Data Range: 0 to 100 %
 Type: Measured
 Suspect Parameter Number: 1716
 Parameter Group Number: [61440]

spn1717 - Actual Maximum Available Retarder - Percent Torque - This is the maximum amount of torque that the retarder can immediately deliver. It is the same as the maximum torque shown in the Retarder's Configuration message, but allows for a much faster rate of change than could be communicated by reissuing the configuration message. Application Note: The purpose for this parameter is to allow a 'Master' retarder controller to more accurately allocate the vehicle's retarder requirements among multiple retarders. Its value should be the same as the value in the Configuration message at the time that message is assembled for broadcast, but may vary between those broadcasts.

Data Length: 1 byte
 Resolution: 1 %/bit , -125% offset
 Data Range: -125 to 125 %
 Operating Range: -125 % to 0
 Type: Measured
 Suspect Parameter Number: 1717
 Parameter Group Number: [61440]

spn1718 - Damper Stiffness Request Front Axle - Demand value for the shock absorber control at the front axle.

Data Length: 1 byte
 Resolution: 0.4 %/bit , 0 offset
 Data Range: 0 to 100 %
 Type: Status
 Suspect Parameter Number: 1718
 Parameter Group Number: [53760]

spn1719 - Damper Stiffness Request Rear Axle - Demand value for the shock absorber control at the rear axle.

Data Length: 1 byte
 Resolution: 0.4 %/bit , 0 offset
 Data Range: 0 to 100 %
 Type: Status
 Suspect Parameter Number: 1719
 Parameter Group Number: [53760]

spn1720 - Damper Stiffness Request Lift / Tag Axle - Demand value for the shock absorber control at the lift or tag axle

Data Length: 1 byte
 Resolution: 0.4 %/bit , 0 offset
 Data Range: 0 to 100 %
 Type: Status
 Suspect Parameter Number: 1720
 Parameter Group Number: [53760]

spn1721 - Relative Level Front Axle Left - Information of the height at the left side of the front axle referred to normal level 1. For explanations of normal level 1 see SPN 1734 - Nominal Level Front Axle.

Data Length: 2 bytes
 Resolution: 0.1 mm/bit , -3,200 mm offset
 Data Range: -3,200 to 3,225.5 mm
 Type: Measured
 Suspect Parameter Number: 1721
 Parameter Group Number: [65113]

spn1722 - Relative Level Front Axle Right - Information of the height at the right side of the front axle referred to normal level 1. For explanations of normal level 1 see SPN 1734 - Nominal Level Front Axle.

Data Length: 2 bytes
 Resolution: 0.1 mm/bit , -3,200 mm offset
 Data Range: -3,200 to 3,225.5 mm
 Type: Measured
 Suspect Parameter Number: 1722
 Parameter Group Number: [65113]

spn1723 - Relative Level Rear Axle Right - Information of the height at the left side of the rear axle referred to normal level 1. For explanations of normal level 1 see parameter SPN 1734 - Nominal Level Front Axle.

Data Length: 2 bytes
 Resolution: 0.1 mm/bit , -3,200 mm offset
 Data Range: -3,200 to 3,225.5 mm
 Type: Measured
 Suspect Parameter Number: 1723
 Parameter Group Number: [65113]

spn1724 - Relative Level Rear Axle Left - Information of the height at the left side of the rear axle referred to normal level 1. For explanations of normal level 1 see parameter SPN 1734 - Nominal Level Front Axle.

Data Length: 2 bytes
 Resolution: 0.1 mm/bit , -3,200 mm offset
 Data Range: -3,200 to 3,225.5 mm
 Type: Measured
 Suspect Parameter Number: 1724
 Parameter Group Number: [65113]

spn1725 - Bellow Pressure Front Axle Left - Information of the pressure of the air suspension bellow at the left side of the front axle

Data Length: 2 bytes
 Resolution: 0.1 kPa/bit , 0 offset
 Data Range: 0 to 6,425.5 kPa
 Type: Measured
 Suspect Parameter Number: 1725
 Parameter Group Number: [65112]

spn1726 - Bellow Pressure Front Axle Right - Information of the pressure of the air suspension bellow at the right side of the front axle

Data Length: 2 bytes
 Resolution: 0.1 kPa/bit , 0 offset
 Data Range: 0 to 6,425.5 kPa
 Type: Measured
 Suspect Parameter Number: 1726
 Parameter Group Number: [65112]

spn1727 - Bellow Pressure Rear Axle Left - Information of the pressure of the air suspension bellow at the left side of the rear axle

Data Length: 2 bytes
 Resolution: 0.1 kPa/bit , 0 offset
 Data Range: 0 to 6,425.5 kPa
 Type: Measured
 Suspect Parameter Number: 1727
 Parameter Group Number: [65112]

spn1728 - Bellow Pressure Rear Axle Right - Information of the pressure of the air suspension bellow at the right side

of the rear axle

Data Length: 2 bytes
 Resolution: 0.1 kPa/bit , 0 offset
 Data Range: 0 to 6,425.5 kPa
 Type: Measured
 Suspect Parameter Number: 1728
 Parameter Group Number: [65112]

spn1729 - Damper Stiffness Front Axle - Damper stiffness information of the shock absorber control at the front axle

Data Length: 1 byte
 Resolution: 0.4 %/bit , 0 offset
 Data Range: 0 to 100 %
 Type: Status
 Suspect Parameter Number: 1729
 Parameter Group Number: [65111]

spn1730 - Damper Stiffness Rear Axle - Damper stiffness information of the shock absorber control at the rear axle

Data Length: 1 byte
 Resolution: 0.4 %/bit , 0 offset
 Data Range: 0 to 100 %
 Type: Status
 Suspect Parameter Number: 1730
 Parameter Group Number: [65111]

spn1731 - Damper Stiffness Lift / Tag Axle - Damper stiffness information of the shock absorber control at the lift of tag axle

Data Length: 1 byte
 Resolution: 0.4 %/bit , 0 offset
 Data Range: 0 to 100 %
 Type: Status
 Suspect Parameter Number: 1731
 Parameter Group Number: [65111]

spn1732 - Level Preset Front Axle Left - Set value for nominal level 'preset level' at the left side of the front axle. This value is referred to 'Normal level 1'. For explanations of normal level 1 see parameter SPN 1734 - Nominal Level Front Axle.

Data Length: 2 bytes
 Resolution: 0.1 mm/bit , -3,200 mm offset
 Data Range: -3,200 to 3,225.5 mm
 Type: Status
 Suspect Parameter Number: 1732
 Parameter Group Number: [53504]

spn1733 - Nominal Level Rear Axle - Signal which indicates the nominal (desired) height of the rear axle to be controlled by the suspension system.

For further explanations see SPN 1734 - Nominal Level Front Axle.

0000 Level not specified,(i.e. the nominal level is none of the specified levels, no error condition)
 0001 "Normal Level 1,(i.e. the level prescribed for normal driving, given by design)
 0010 "Normal Level 2,(i.e. a level permitted for driving, for example to lower the vehicle in case of high speed)
 0011 "Normal Level 3,(i.e. a level permitted for driving, for example to lift the vehicle in case of offroad)
 0100 "Preset Level,(i.e. a level to be defined externally via CAN)
 0101 "Customer Level,(i.e. a level to be defined by customer via parameter setting)
 0110 "Upper Level,(i.e. the highest level to be controlled)
 0111 "Lower Level,(i.e. the lowest level to be controlled)
 1000-1101 Not defined
 1110 Error
 1111 Not available

Bit Length: 4 bits
 Type: Status
 Suspect Parameter Number: 1733
 Parameter Group Number: [65114]

spn1734 - Nominal Level Front Axle - Signal which indicates the nominal (desired) height of the front axle to be controlled by the suspension system.

These heights are discrete levels. They are the upper level, lower level, normal level 1, normal level 2, normal level 3, customer level, and preset level. Refer to Figure SPN1734_A.

- Upper Level is the highest mechanically available height of the vehicle.
- Lower Level is the lowest mechanically available height of the vehicle.

Normal Levels 1, 2 and 3 are heights normally used during driving.

- Normal Level 1 is most often used and is given by design.
- Normal Level 2 may be chosen, for example, to be lower than Normal Level 1 for the purpose of reducing fuel consumption while driving on highways.
- Normal Level 3 may be chosen above Normal Level 1 for driving off road.

The preset level has to be set by means of ASC 6 (PGN: 53504).

0000 Level not specified,(i.e. the nominal level is none of the specified levels, no error condition)
 0001 "Normal Level 1,(i.e. the level prescribed for normal driving, given by design)
 0010 "Normal Level 2,(i.e. a level permitted for driving, for example to lower the vehicle in case of high speed)
 0011 "Normal Level 3,(i.e. a level permitted for driving, for example to lift the vehicle in case of offroad)
 0100 "Preset Level,(i.e. a level to be defined externally via CAN)
 0101 "Customer Level,(i.e. a level to be defined by customer via parameter setting)
 0110 "Upper Level,(i.e. the highest level to be controlled)
 0111 "Lower Level,(i.e. the lowest level to be controlled)
 1000-1101 Not defined
 1110 Error
 1111 Not available

Bit Length: 4 bits
 Type: Status
 Suspect Parameter Number: 1734
 Parameter Group Number: [65114]

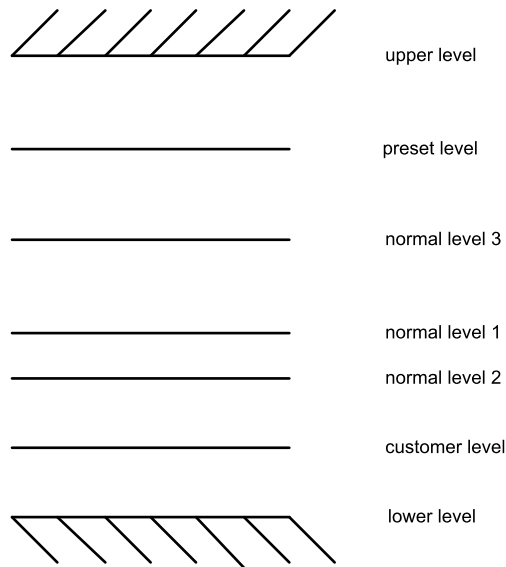

If the vehicle height, to be controlled by the ASC, is not within the tolerances of the defined nominal levels, the nominal level is set to not specified.

The defined vehicle heights can be activated via the ASC 2 (PGN: 53760) message or via a remote control (see figure SPN1734_B). The remote control is an external unit to operate the suspension system.

FIGURE SPN1734_A: Example for nominal levels

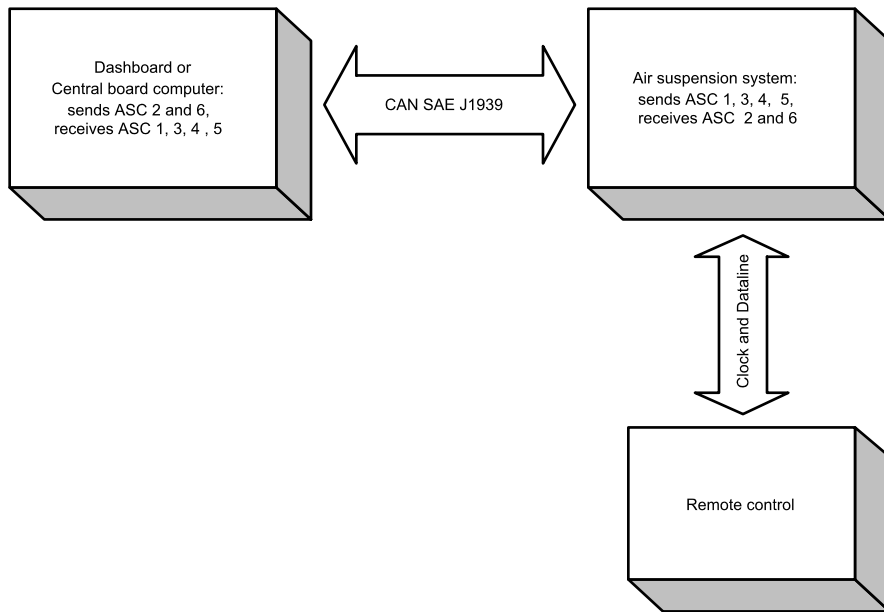

An example: The nominal level is the normal level 1. Via remote control a new nominal level (for instance upper level) is requested. The nominal level is then set to upper level and during the height modification the ASC is indicating that the actual level is below nominal level until the upper level is reached.

FIGURE SPN1734_B: Possible integration of ASC system into vehicle network

spn1735 - Level Preset Rear Axle Right - Set value for nominal level 'preset level' at the right side of the rear axle. This value is referred to 'Normal level 1'. For explanations of normal level 1 see SPN 1734 - Nominal Level Front Axle.

Data Length: 2 bytes
 Resolution: 0.1 mm/bit , -3,200 mm offset
 Data Range: -3,200 to 3,225.5 mm
 Type: Status
 Suspect Parameter Number: 1735
 Parameter Group Number: [53504]

spn1736 - Above Nominal Level Rear Axle - Signal which indicates whether the actual height of the rear axle is above the nominal (desired) level of the rear axle. For explanations of nominal level see parameter SPN 1734 - Nominal Level Front Axle.

- 00 Not above
- 01 Above
- 10 Error
- 11 Not available

Bit Length: 2 bits
 Type: Measured
 Suspect Parameter Number: 1736
 Parameter Group Number: [65114]

spn1737 - Above Nominal Level Front Axle - Signal which indicates whether the actual height of the front axle is above the nominal (desired) level of the front axle. For explanations of nominal level see SPN 1734 - Nominal Level Front Axle.

- 00 Not above
- 01 Above
- 10 Error
- 11 Not available

Bit Length: 2 bits
 Type: Measured
 Suspect Parameter Number: 1737
 Parameter Group Number: [65114]

spn1738 - Below Nominal Level Front Axle - Signal which indicates whether the actual height of the front axle is below the nominal (desired) level for the front axle. For explanations of nominal level see parameter SPN 1734 - Nominal Level Front Axle.

- 00 Not below
- 01 Below
- 10 Error
- 11 Not available

Bit Length: 2 bits
 Type: Measured
 Suspect Parameter Number: 1738
 Parameter Group Number: [65114]

spn1739 - Lifting Control Mode Front Axle - Signal which indicates the actual lifting level change at the front axle

- 00 Lifting not active
- 01 Lifting active
- 10 Error
- 11 Not available

Bit Length: 2 bits
 Type: Status
 Suspect Parameter Number: 1739
 Parameter Group Number: [65114]

spn1740 - Lowering Control Mode Front Axle - Signal which indicates the actual lowering level change at the front axle

- 00 Lowering not active
- 01 Lowering active
- 10 Error
- 11 Not available

Bit Length: 2 bits
 Type: Status
 Suspect Parameter Number: 1740
 Parameter Group Number: [65114]

spn1741 - Level Control Mode - Signal which indicates the actual control mode of the air suspension system

- 0000 Normal operation,(i.e. the system performs a ""pure"" control of the vehicle height)
- 0001 Traction help (load transfer),(i.e. the driven axle is loaded to a maximum value given by legislation or design)
- 0010 Load fixing,(i.e. the driven axlen is loaded to a value defined by the driver)
- 0011 Pressure ratio 1,(i.e. the ratio between the pressures at the driven axle and at the third axle is controlled, so that the ratio equals a fixed value 1)
- 0100 Pressure ratio 2,(i.e. the ratio between the pressures at the driven axle and at the third axle is controlled, so that the ratio equals a fixed value 2)
- 0101 Optimum traction 1,(i.e. the pressure at the driven axle is controlled at a fixed value 1)

0110 Optimum traction 2,(i.e. the pressure at the driven axle is controlled at a fixed value 2)
 0111-1101 Not defined
 1110 Error
 1111 Not available

Bit Length: 4 bits
 Type: Status
 Suspect Parameter Number: 1741
 Parameter Group Number: [65114]

spn1742 - Kneeling Information - Signal which indicates the actual level change in case of kneeling function

0000 Not active,(i.e. the kneeling function is not active")
 0001 Lowering active,(i.e. the vehicle is lowered due to a kneeling request)
 0010 Kneeling level reached,(i.e. the vehicle is at the fixed kneeling level)
 0011 Lifting active,(i.e. the vehicle is lifted due to a recover request)
 0100 Kneeling aborted,(i.e. in case of manual actuation the request was dropped before the kneeling level was reached)
 0101-1101 Not defined
 1110 Error
 1111 Not available

Bit Length: 4 bits
 Type: Status
 Suspect Parameter Number: 1742
 Parameter Group Number: [65114]

spn1743 - Lift Axle 1 Position - Signal which indicates the position / load condition of lift axle / tag axle #1. Numbering of lift/tag axles starts at front axle.

00 Lift axle position down / tag axle laden
 01 Lift axle position up / tag axle unladen
 10 Error
 11 Not available

Bit Length: 2 bits
 Type: Measured
 Suspect Parameter Number: 1743
 Parameter Group Number: [65114]

spn1744 - Door Release - Signal which indicates that the doors may be opened. [Please note: doors instead of door!]

In case a kneeling request is active the ASC indicates during lowering the vehicle 'doors shall not be opened' as a security information until the kneeling level is reached. Then "doors may be opened" is sent.
 00 Doors may not be opened
 01 Doors may be opened
 10 Error
 11 Not available

Bit Length: 2 bits
 Type: Status
 Suspect Parameter Number: 1744
 Parameter Group Number: [65114]

spn1745 - Vehicle Motion Inhibit - Signal which indicates whether vehicle motion is inhibited.

00 Vehicle may be moved
 01 Vehicle motion is inhibited
 10 Error
 11 Not available

Bit Length: 2 bits
 Type: Status
 Suspect Parameter Number: 1745

Parameter Group Number: [65114]

spn1746 - Security Device - The signal which indicates the status of the security device. An example of a security device is a curbstone feeler installed beneath the doors of a bus. If the security device becomes active during kneeling the kneeling process (lowering) is stopped and the vehicle lifts back to the starting level.

- 00 Not active
- 01 Active
- 10 Error
- 11 Not available

Bit Length: 2 bits

Type: Status

Suspect Parameter Number: 1746

Parameter Group Number: [65114]

spn1747 - Kneeling Control Mode Request - Command signal to select the kneeling functionality

- 00 Automatically actuated
- 01 Manually actuated
- 10 Reserved
- 11 Don't care/take no action

Bit Length: 2 bits

Type: Status

Suspect Parameter Number: 1747

Parameter Group Number: [53760]

spn1748 - Kneeling Request Right Side - Command signal to activate the kneeling functionality on the right side of the vehicle

- 00 No kneeling request
- 01 Kneeling request
- 10 Reserved
- 11 Don't care/take no action

Bit Length: 2 bits

Type: Status

Suspect Parameter Number: 1748

Parameter Group Number: [53760]

spn1749 - Kneeling Request Left Side - Command signal to activate the kneeling functionality on the left side of the vehicle

- 00 No kneeling request
- 01 Kneeling request
- 10 Reserved
- 11 Don't care/take no action

Bit Length: 2 bits

Type: Status

Suspect Parameter Number: 1749

Parameter Group Number: [53760]

spn1750 - Nominal Level Request Rear Axle - Command signal to activate a level of the rear axle programmed and/or memorised in the ECU. For explanations of nominal level see SPN 1734 - Nominal Level Front Axle.

- 0000 No level request
- 0001 Normal Level 1,(i.e. the level prescribed for normal driving, given by design)
- 0010 Normal Level 2,(i.e. a level permitted for driving, for example to lower the vehicle in case of high speed)

0011 Normal Level 3,(i.e. a level permitted for driving, for example to lift the vehicle in case of offroad)
 0100 Preset Level,(i.e. a level to be defined externally via CAN)
 0101 Customer Level,(i.e. a level to be defined by customer via parameter setting)
 0110 Upper Level,(i.e. the highest level to be controlled)
 0111 Lower Level,(i.e. the lowest level to be controlled)
 1000 Stop level change,(i.e. the level change in process shall be stopped immediately)
 1001-1101 Not defined
 1110 Reserved
 1111 Don't care/take no action

Bit Length: 4 bits
 Type: Status
 Suspect Parameter Number: 1750
 Parameter Group Number: [53760]

spn1751 - Nominal Level Request Front Axle - Command signal to activate a level of the front axle programmed and/or memorised in the ECU For explanations of nominal level see SPN 1734 - Nominal Level Front Axle.

0000 No level request
 0001 Normal Level 1,(i.e. the level prescribed for normal driving, given by design)
 0010 Normal Level 2,(i.e. a level permitted for driving, for example to lower the vehicle in case of high speed)
 0011 Normal Level 3,(i.e. a level permitted for driving, for example to lift the vehicle in case of offroad)
 0100 Preset Level,(i.e. a level to be defined externally via CAN)
 0101 Customer Level,(i.e. a level to be defined by customer via parameter setting)
 0110 Upper Level,(i.e. the highest level to be controlled)
 0111 Lower Level,(i.e. the lowest level to be controlled)
 1000 Stop level change,(i.e. the level change in process shall be stopped immediately)
 1001-1101 Not defined
 1110 Reserved
 1111 Don't care/take no action

Bit Length: 4 bits
 Type: Status
 Suspect Parameter Number: 1751
 Parameter Group Number: [53760]

spn1752 - Lift Axle 1 Position Command - Signal to command the position/load condition of lift/tag axle #1. Numbering of lift/tag axles starts at front axle.

00 Lift axle position down / tag axle laden
 01 Lift axle position up / tag axle unladen
 10 Reserved
 11 Don't care/take no action

Bit Length: 2 bits
 Type: Status
 Suspect Parameter Number: 1752
 Parameter Group Number: [53760]

spn1753 - Level Control Mode Request - Command signal to activate a level control mode

0000 Normal operation,(i.e. the system performs a ""pure"" control of the vehicle height)
 0001 Traction help (load transfer),(i.e. the driven axle is loaded to a maximum value given by legislation or design)
 0010 Load fixing,(i.e. the driven axlen is loaded to a value defined by the driver)
 0011 Pressure ratio 1,(i.e. the ratio between the pressures at the driven axle and at the third axle is controlled, so that the ratio equals a fixed value 1)
 0100 Pressure ratio 2,(i.e. the ratio between the pressures at the driven axle and at the third axle is controlled, so that the ratio equals a fixed value 2)
 0101 Optimum traction 1,(i.e. the pressure at the driven axle is controlled at a fixed value 1)
 0110 Optimum traction 2,(i.e. the pressure at the driven axle is controlled at a fixed value 2)
 0111-1101 Not defined
 1110 Reserved
 1111 Don't care/take no action

Bit Length: 4 bits

Type: Status
 Suspect Parameter Number: 1753
 Parameter Group Number: [53760]

spn1754 - Below Nominal Level Rear Axle - Signal which indicates whether the actual height of the rear axle is below the nominal (desired) level for the rear axle. For explanations of nominal level see SPN 1734 - Nominal Level Front Axle.

00 Not below
 01 Below
 10 Error
 11 Not available

Bit Length: 2 bits
 Type: Status
 Suspect Parameter Number: 1754
 Parameter Group Number: [65114]

spn1755 - Lowering Control Mode Rear Axle - Signal which indicates the actual lowering level change at the rear axle

00 Lowering not active
 01 Lowering active
 10 Error
 11 Not available

Bit Length: 2 bits
 Type: Status
 Suspect Parameter Number: 1755
 Parameter Group Number: [65114]

spn1756 - Lifting Control Mode Rear Axle - Signal which indicates the actual lifting level change at the rear axle

00 Lifting not active
 01 Lifting active
 10 Error
 11 Not available

Bit Length: 2 bits
 Type: Status
 Suspect Parameter Number: 1756
 Parameter Group Number: [65114]

spn1757 - Level Preset Front Axle Right - Set value for nominal level 'preset level' at the right side of the front axle.

This value is referred to 'Normal level 1'. For explanations of normal level 1 see SPN 1734 - Nominal Level Front Axle.

Data Length: 2 bytes
 Resolution: 0.1 mm/bit , -3,200 mm offset
 Data Range: -3,200 to 3,225.5 mm
 Type: Status
 Suspect Parameter Number: 1757
 Parameter Group Number: [53504]

spn1758 - Level Preset Rear Axle Left - Set value for nominal level 'preset level' at the left side of the rear axle. This value is referred to 'Normal level 1'. For explanations of normal level 1 see SPN 1734 - Nominal Level Front Axle.

Data Length: 2 bytes
 Resolution: 0.1 mm/bit , -3,200 mm offset

Data Range: -3,200 to 3,225.5 mm
 Type: Status
 Suspect Parameter Number: 1758
 Parameter Group Number: [53504]

spn1759 - Blade Height Set Point - High Resolution - High resolution for the laser guided blade set point. The high resolution required for more accurate control and 'accurate' unit conversions. Negative values are below grade, positive values are above grade, zero is on grade.

Data Length: 4 bytes
 Resolution: 100 nm/bit , -209.7152 m offset
 Data Range: -209.7152 m to 211.3929215 m
 Operating Range: -209.7152m to 209.7152m
 Type: Measured
 Suspect Parameter Number: 1759
 Parameter Group Number: [65140]

spn1760 - Gross Combination Vehicle Weight - The total weight of the truck and all attached trailers.

Data Length: 2 bytes
 Resolution: 10 kg/bit , 0 offset
 Data Range: 0 to 642,550 kg
 Type: Measured
 Suspect Parameter Number: 1760
 Parameter Group Number: [65136]

spn1761 - Catalyst Tank Level - A special catalyst uses chemical substance to reach legal requirement for NOX emissions. This parameter indicates the level within that catalyst tank. 0 % = Empty 100% = Full

Data Length: 1 byte
 Resolution: 0.4 %/bit , 0 offset
 Data Range: 0 to 100 %
 Type: Measured
 Suspect Parameter Number: 1761
 Parameter Group Number: [65110]

spn1762 - Hydraulic Pressure - Hydraulic pressure measured at the output of the hydraulic pump.

Data Length: 2 bytes
 Resolution: 2 kPa/bit , 0 offset
 Data Range: 0 to 128,510 kPa
 Type: Measured
 Suspect Parameter Number: 1762
 Parameter Group Number: [61448]

spn1763 - Hydraulic Pressure Mode Indicator - Mode for governor operation is hydraulic pressure control.

- 00 Disabled
- 01 Enabled
- 10 Error Indicator
- 11 Not Available

Bit Length: 2 bits
 Type: Status
 Suspect Parameter Number: 1763
 Parameter Group Number: [61448]

spn1764 - Hydraulic Pressure Governor Switch - Switch that sets the mode of hydraulic governor

00 Pressure Mode Inactive
 01 Pressure Mode Active
 10 Error Indicator
 11 Not Available

Bit Length: 2 bits
 Type: Measured
 Suspect Parameter Number: 1764
 Parameter Group Number: [61448]

spn1765 - Requested Fuel Valve 1 Position - The requested position of a gaseous fuel valve 1 that is metering the fuel flow to the engine.

Data Length: 1 byte
 Resolution: 0.4 %/bit , 0 offset
 Data Range: 0 to 100 %
 Type: Status
 Suspect Parameter Number: 1765
 Parameter Group Number: [65153]

spn1766 - Requested Fuel Valve 2 Position - The requested position of a gaseous fuel valve 2 that is metering the fuel flow to the engine, as requested by the Engine Control Unit.

Data Length: 1 byte
 Resolution: 0.4 %/bit , 0 offset
 Data Range: 0 to 100 %
 Type: Status
 Suspect Parameter Number: 1766
 Parameter Group Number: [65153]

spn1767 - Specific Heat Ratio - The specific heat ratio of the fuel.

Data Length: 2 bytes
 Resolution: 0.001/bit , 0 offset
 Data Range: 0 to 64.255
 Operating Range: 0 to 2.0000
 Type: Status
 Suspect Parameter Number: 1767
 Parameter Group Number: [65109]

spn1768 - Low Limit Threshold for Maximum RPM from Engine - Minimum allowable value for maximum continuous RPM from engine

Data Length: 1 byte
 Resolution: 32 rpm/bit , 0 offset

Data Range: 0 to 8,000 rpm
 Type: Status
 Suspect Parameter Number: 1768
 Parameter Group Number: [65108]

spn1769 - High Limit Threshold for Minimum Continuous Engine RPM - Maximum allowable value for minimum continuous RPM from engine

Data Length: 1 byte
 Resolution: 32 rpm/bit , 0 offset
 Data Range: 0 to 8,000 rpm
 Type: Status
 Suspect Parameter Number: 1769
 Parameter Group Number: [65108]

spn1770 - Low Limit Threshold for Maximum Torque from Engine - Minimum allowable value for maximum continuous torque. From engine

Data Length: 1 byte
 Resolution: 1 %/bit , -125% offset
 Data Range: -125 to 125 %
 Type: Status
 Suspect Parameter Number: 1770
 Parameter Group Number: [65108]

spn1771 - High Limit Threshold for Minimum Continuous Torque from Engine - Maximum allowable value for minimum continuous torque. From engine

Data Length: 1 byte
 Resolution: 1 %/bit , -125% offset
 Data Range: -125 to 125 %
 Type: Status
 Suspect Parameter Number: 1771
 Parameter Group Number: [65108]

spn1772 - Maximum Continuous Engine RPM - Applied limit for maximum continuous engine RPM

Data Length: 1 byte
 Resolution: 32 rpm/bit , 0 offset
 Data Range: 0 to 8,000 rpm
 Type: Status
 Suspect Parameter Number: 1772
 Parameter Group Number: [65108]

spn1773 - Minimum Continuous Engine RPM - Applied limit for minimum continuous engine RPM

Data Length: 1 byte
 Resolution: 32 rpm/bit , 0 offset
 Data Range: 0 to 8,000 rpm

Type: Status
 Suspect Parameter Number: 1773
 Parameter Group Number: [65108]

spn1774 - Maximum Continuous Engine Torque - Applied limit for maximum continuous engine torque.

Data Length: 1 byte
 Resolution: 1 %/bit , -125% offset
 Data Range: -125 to 125 %
 Type: Status
 Suspect Parameter Number: 1774
 Parameter Group Number: [65108]

spn1775 - Minimum Continuous Engine Torque - Applied limit for minimum continuous engine torque

Data Length: 1 byte
 Resolution: 1 %/bit , -125% offset
 Data Range: -125 to 125 %
 Type: Status
 Suspect Parameter Number: 1775
 Parameter Group Number: [65108]

spn1776 - Low Limit Threshold for Maximum RPM from Retarder - Minimum allowable value for maximum continuous retarder speed

Data Length: 1 byte
 Resolution: 32 rpm/bit , 0 offset
 Data Range: 0 to 8,000 rpm
 Type: Status
 Suspect Parameter Number: 1776
 Parameter Group Number: [65107]

spn1777 - High Limit Threshold for Minimum Continuous RPM from Retarder - Maximum allowable value for minimum continuous retarder speed

Data Length: 1 byte
 Resolution: 32 rpm/bit , 0 offset
 Data Range: 0 to 8,000 rpm
 Type: Status
 Suspect Parameter Number: 1777
 Parameter Group Number: [65107]

spn1778 - Low Limit Threshold for Maximum Torque from Retarder - Minimum allowable value for maximum continuous retarder torque.

Data Length: 1 byte
 Resolution: 1 %/bit , -125% offset
 Data Range: -125 to 125 %
 Type: Status

Suspect Parameter Number: 1778
 Parameter Group Number: [65107]

spn1779 - High Limit Threshold for Minimum Continuous Torque from Retarder - Maximum allowable value for minimum continuous retarder torque.

Data Length: 1 byte
 Resolution: 1 %/bit , -125% offset
 Data Range: -125 to 125 %
 Type: Status
 Suspect Parameter Number: 1779
 Parameter Group Number: [65107]

spn1780 - Maximum Continuous Retarder Speed - Applied limit for maximum continuous retarder RPM

Data Length: 1 byte
 Resolution: 32 rpm/bit , 0 offset
 Data Range: 0 to 8,000 rpm
 Type: Status
 Suspect Parameter Number: 1780
 Parameter Group Number: [65107]

spn1781 - Minimum Continuous Retarder Speed - Applied limit for minimum continuous retarder RPM

Data Length: 1 byte
 Resolution: 32 rpm/bit , 0 offset
 Data Range: 0 to 8,000 rpm
 Type: Status
 Suspect Parameter Number: 1781
 Parameter Group Number: [65107]

spn1782 - Maximum Continuous Retarder Torque - Applied limit for maximum continuous retarder torque.

Data Length: 1 byte
 Resolution: 1 %/bit , -125% offset
 Data Range: -125 to 125 %
 Type: Status
 Suspect Parameter Number: 1782
 Parameter Group Number: [65107]

spn1783 - Minimum Continuous Retarder Torque - Applied limit for minimum continuous retarder torque

Data Length: 1 byte
 Resolution: 1 %/bit , -125% offset
 Data Range: -125 to 125 %
 Type: Status
 Suspect Parameter Number: 1783
 Parameter Group Number: [65107]

spn1784 - Minimum Continuous Engine Speed Limit Request - Requested minimum continuous engine speed

Data Length: 1 byte
 Resolution: 32 rpm/bit , 0 offset
 Data Range: 0 to 8,000 rpm
 Type: Status
 Suspect Parameter Number: 1784
 Parameter Group Number: [52992]

spn1785 - Maximum Continuous Engine Speed Limit Request - Requested maximum continuous engine speed

Data Length: 1 byte
 Resolution: 32 rpm/bit , 0 offset
 Data Range: 0 to 8,000 rpm
 Type: Status
 Suspect Parameter Number: 1785
 Parameter Group Number: [52992]

spn1786 - Minimum Continuous Engine Torque Limit Request - Requested minimum continuous engine torque (operating range: 0 to 125%)

Data Length: 1 byte
 Resolution: 1 %/bit , -125% offset
 Data Range: -125 to 125 %
 Operating Range: 0 to 125%
 Type: Status
 Suspect Parameter Number: 1786
 Parameter Group Number: [52992]

spn1787 - Maximum Continuous Engine Torque Limit Request - Requested maximum continuous engine torque (operating range: 0 to 125%)

Data Length: 1 byte
 Resolution: 1 %/bit , -125% offset
 Data Range: -125 to 125 %
 Operating Range: 0 to 125%
 Type: Status
 Suspect Parameter Number: 1787
 Parameter Group Number: [52992]

spn1788 - Minimum Continuous Retarder Speed Limit Request - Requested minimum continuous retarder speed

Data Length: 1 byte
 Resolution: 32 rpm/bit , 0 offset
 Data Range: 0 to 8,000 rpm
 Type: Status
 Suspect Parameter Number: 1788
 Parameter Group Number: [52992]

spn1789 - Maximum Continuous Retarder Speed Limit Request - Requested maximum continuous retarder speed

Data Length: 1 byte
 Resolution: 32 rpm/bit , 0 offset
 Data Range: 0 to 8,000 rpm
 Type: Status
 Suspect Parameter Number: 1789
 Parameter Group Number: [52992]

spn1790 - Minimum Continuous Retarder Torque Limit Request - Requested minimum continuous retarder torque (operating range: -125 to 0%)

Data Length: 1 byte
 Resolution: 1 %/bit , -125% offset
 Data Range: -125 to 125 %
 Operating Range: -125 to 0%
 Type: Status
 Suspect Parameter Number: 1790
 Parameter Group Number: [52992]

spn1791 - Maximum Continuous Retarder Torque Limit Request - Requested maximum continuous retarder torque (operating range: -125 to 0%)

Data Length: 1 byte
 Resolution: 1 %/bit , -125% offset
 Data Range: -125 to 125 %
 Operating Range: -125 to 0%
 Type: Status
 Suspect Parameter Number: 1791
 Parameter Group Number: [52992]

spn1792 - Tractor-Mounted Trailer ABS Warning Signal - This parameter commands the tractor-mounted trailer ABS optical warning signal.

- 00 Off
- 01 On
- 10 Reserved
- 11 Take no action

Bit Length: 2 bits
 Type: Status
 Suspect Parameter Number: 1792
 Parameter Group Number: [61441]

spn1793 - ATC/ASR Information Signal - This parameter commands the ATC/ASR driver information signal, for example a dash lamp.

- 00 Off
- 01 On
- 10 Reserved
- 11 Take no action

Bit Length: 2 bits

Type: Status
 Suspect Parameter Number: 1793
 Parameter Group Number: [61441]

spn1794 - Engine Moment of Inertia - Moment of inertia for the engine, including items driven full-time by the engine such as fuel, oil and cooling pumps. The inertia from the following items are not included: flywheel, alternator, compressor, fan, and other engine-driven accessories.

Data Length: 2 bytes
 Resolution: 0.004 kg-m²/bit , 0 offset
 Data Range: 0 to 257.02 kg-m²
 Type: Status
 Suspect Parameter Number: 1794
 Parameter Group Number: [65251]

spn1795 - Alternator Current (High Range/Resolution) - This parameter indicates the amount of electrical current output from the alternator of the main vehicle. Alternator Current (SPN 115) has a lower range and resolution.

Data Length: 2 bytes
 Resolution: 0.05 A/bit , -1600 A offset
 Data Range: -1600 to 1612.75 A
 Type: Measured
 Suspect Parameter Number: 1795
 Parameter Group Number: [65106]

spn1796 - ACC Distance Alert Signal - Signal to indicate to the operator that the ACC system is not able to maintain the distance to the target. Example: Target stopping rapidly. This signal may be used to activate warning sounds or indicators.

- 00 ACC DAS Not Active
- 01 ACC DAS Active
- 10 Reserved
- 11 Take no action

Bit Length: 2 bits
 Type: Status
 Suspect Parameter Number: 1796
 Parameter Group Number: [65135]

spn1797 - ACC System Shutoff Warning - Signal to warn the driver of system deactivation due to non-driver actions. Example: Attempting to control vehicle speed below or above limits of ACC. This signal may be used to activate warning sounds or indicators.

- 00 ACC SSOW Not Active
- 01 ACC SSOW Active
- 10 Reserved
- 11 Take no action

Bit Length: 2 bits
 Type: Status
 Suspect Parameter Number: 1797
 Parameter Group Number: [65135]

spn1798 - ACC Target Detected - Signal to indicate to the driver that the ACC system has detected a target.

- 00 No targets detected
- 01 Target detected
- 10 Reserved
- 11 Take no action

Bit Length: 2 bits
 Type: Status
 Suspect Parameter Number: 1798
 Parameter Group Number: [65135]

spn1799 - Requested ACC Distance Mode - The Requested Distance Control Mode to the ACC system from the operators interface.

The ACC Set Distance Mode (SPN 1589) indicates the selected Distance Control Mode for the ACC system. This parameter is the driver requested setting for this.

- 000 Requested ACC Distance Mode #1 (largest distance)
- 001 Requested ACC Distance Mode #2
- 010 Requested ACC Distance Mode #3
- 011 Requested ACC Distance Mode #4
- 100 Requested ACC Distance Mode #5 (shortest distance)
- 101 not defined
- 110 error condition
- 111 not available

Bit Length: 3 bits
 Type: Measured
 Suspect Parameter Number: 1799
 Parameter Group Number: [65105]

spn1800 - Battery 1 Temperature - Temperature of the battery 1. The relation to physical location is determined by the equipment manufacturer.

Data Length: 1 byte
 Resolution: 1 deg C/bit , -40 deg C offset
 Data Range: -40 to 210 deg C
 Type: Measured
 Suspect Parameter Number: 1800
 Parameter Group Number: [65104]

spn1801 - Battery 2 Temperature - Temperature of the battery 2. The relation to physical location is determined by the equipment manufacturer.

Data Length: 1 byte
 Resolution: 1 deg C/bit , -40 deg C offset
 Data Range: -40 to 210 deg C
 Type: Measured
 Suspect Parameter Number: 1801
 Parameter Group Number: [65104]

spn1802 - Intake Manifold 5 Temperature - Temperature of pre-combustion air found in intake manifold number 5 of engine air supply system.

Data Length: 1 byte
 Resolution: 1 deg C/bit , -40 deg C offset
 Data Range: -40 to 210 deg C

Type: Measured
 Suspect Parameter Number: 1802
 Parameter Group Number: [65189]

spn1803 - Intake Manifold 6 Temperature - Temperature of pre-combustion air found in intake manifold number 6 of engine air supply system.

Data Length: 1 byte
 Resolution: 1 deg C/bit , -40 deg C offset
 Data Range: -40 to 210 deg C
 Type: Measured
 Suspect Parameter Number: 1803
 Parameter Group Number: [65189]

spn1805 - LED Display Mode Control - This parameter informs the system what the selected Display mode will be.

0000 - Center On-Grade Display Mode 1 (5 CHANNEL)
 0001 - Offset On-Grade Display Mode
 0010 - Center On-Grade Display Mode 2 (7 CHANNEL)
 0011 - 1110 Reserved
 1111 - Not Available or Not Applicable

Bit Length: 4 bits
 Type: Status
 Suspect Parameter Number: 1805
 Parameter Group Number: [65142]

spn1806 - LED Display Deadband Control - This parameter informs the system what the selected Display deadband will be.

0000 +/- 4.5 mm (0.015 feet, 0.18 inches)
 0001 +/- 12 mm (0.040 feet, 0.45 inches)
 0010 +/- 24 mm (0.080 feet, 0.96 inches)
 0011 +/- 5 mm (0.017 feet, 0.2 inches)
 0100 +/- 1 mm (0.003 feet, 0.04 inches)
 0101 - 1110 Reserved
 1111 Not Available or Not applicable

Bit Length: 4 bits
 Type: Status
 Suspect Parameter Number: 1806
 Parameter Group Number: [65142]

spn1807 - Steering Wheel Angle - The main operator`s steering wheel angle (on the steering column, not the actual wheel angle). The vehicle being steered to the left results in a positive steering wheel angle.

Data Length: 2 bytes
 Resolution: 1/1024 rad per bit , -31.374 rad offset
 Data Range: -31.374 to +31.374 rad
 Type: Measured
 Suspect Parameter Number: 1807
 Parameter Group Number: [61449]

spn1808 - Yaw Rate - Indicates the rotation about the vertical axis. A positive yaw rate signal results when the vehicle turns

counter-clockwise.

Data Length: 2 bytes
 Resolution: 1/8192 rad/s per bit , -3.92 rad/s offset
 Data Range: -3.92 to +3.92 rad/s
 Type: Measured
 Suspect Parameter Number: 1808
 Parameter Group Number: [61449]

spn1809 - Lateral Acceleration - Indicates a lateral acceleration of the vehicle. A positive lateral acceleration signal results when the vehicle is accelerated to the left.

Data Length: 2 bytes
 Resolution: 1/2048 m/s# per bit , -15.687 m/s# offset
 Data Range: -15.687 to +15.687 m/s#
 Type: Measured
 Suspect Parameter Number: 1809
 Parameter Group Number: [61449]

spn1810 - Longitudinal Acceleration - Indicates the longitudinal acceleration of the vehicle. A positive longitudinal acceleration signal results when the vehicle speed increases, regardless of driving the vehicle forward or backward.

Data Length: 1 byte
 Resolution: 0.1 m/s# per bit , -12.5 m/s# offset
 Data Range: -12.5 to +12.5 m/s#
 Type: Measured
 Suspect Parameter Number: 1810
 Parameter Group Number: [61449]

spn1811 - Steering Wheel Turn Counter - Indicates number of steering wheel turns, absolute position or relative position at ignition on. Positive values indicate left turns.

Data Length: 6 bits
 Resolution: 1 turn/bit , -32 turns offset
 Data Range: -32 to 29 turns
 Operating Range: -10 to +10 Turns
 Type: Measured
 Suspect Parameter Number: 1811
 Parameter Group Number: [61449]

spn1812 - Steering Wheel Angle Sensor Type - Indicates whether the steering wheel angle sensor is capable of absolute measuring of the number of steering wheel turns or not (relative measuring to position at ignition on).

- 00 Relative measuring principle
- 01 Absolute measuring principle
- 10 Reserved
- 11 Not Available

Bit Length: 2 bits
 Type: Status
 Suspect Parameter Number: 1812
 Parameter Group Number: [61449]

spn1813 - VDC Information Signal - This parameter commands the VDC information signal, for example a dash lamp.

00 Off
01 On
10 Reserved
11 Don't care/Take no action

Bit Length: 2 bits
Type: Status
Suspect Parameter Number: 1813
Parameter Group Number: [65103]

spn1814 - VDC Fully Operational - Signal that indicates whether VDC is fully operational or whether its functionality is reduced by a permanent or temporary (e.g. low voltage) defect, by intended action (e.g. disabled by a switch or during special diagnostic procedures), not configured or not yet fully initialized (e.g. missing initialization or configuration message). VDC contains ROP and YC.

00 Not fully operational
01 Fully operational
10 Reserved
11 Don't care/Take no action

Bit Length: 2 bits
Type: Status
Suspect Parameter Number: 1814
Parameter Group Number: [65103]

spn1815 - VDC brake light request - Indicates whether VDC requests to turn the vehicle brake lights on

00 Turn brake light not on
01 Turn brake light on
10 Reserved
11 Don't care/Take no action

Bit Length: 2 bits
Type: Status
Suspect Parameter Number: 1815
Parameter Group Number: [65103]

spn1816 - ROP Engine Control active - State Signal which indicates that the Roll Over Prevention (ROP) has commanded engine control to be active. Within the physical limits, ROP attempts to prevent rolling over of the vehicle. Active means that ROP actually tries to control the engine. This state signal is independent of other control commands to the engine which may have higher priority.

00 ROP engine control passive but installed
01 ROP engine control active
10 Reserved
11 Don't care/Take no action

Bit Length: 2 bits
Type: Status
Suspect Parameter Number: 1816
Parameter Group Number: [65103]

spn1817 - YC Engine Control active - State Signal which indicates that the Yaw Control (YC) has commanded engine control to be active. Within the physical limits, YC attempts to prevent yawing of the vehicle. Active means that YC actually tries to control the engine. This state signal is independent of other control commands to the engine which may have higher priority.

00 YC engine control passive but installed
01 YC engine control active

- 10 Reserved
- 11 Don't care/Take no action

Bit Length: 2 bits
 Type: Status
 Suspect Parameter Number: 1817
 Parameter Group Number: [65103]

spn1818 - ROP Brake Control active - State signal which indicates that Roll over Prevention (ROP) has activated brake control. Active means that ROP actually controls wheel brake pressure at one or more wheels of the vehicle or vehicle combination.

Within the physical limits, ROP attempts to prevent rolling over of the vehicle.

- 00 ROP brake control passive but installed
- 01 ROP brake control active
- 10 Reserved
- 11 Don't care/Take no action

Bit Length: 2 bits
 Type: Status
 Suspect Parameter Number: 1818
 Parameter Group Number: [65103]

spn1819 - YC Brake Control active - State signal which indicates that Yaw Control (YC) has activated brake control.

Active means that YC actually controls wheel brake pressure at one or more wheels of the vehicle or vehicle combination. Within the physical limits, YC attempts to prevent yawing of the vehicle.

- 00 YC brake control passive but installed
- 01 YC brake control active
- 10 Reserved
- 11 Don't care/Take no action

Bit Length: 2 bits
 Type: Status
 Suspect Parameter Number: 1819
 Parameter Group Number: [65103]

spn1820 - Ramp / Wheel Chair Lift Position - Signal which indicates the actual position of the ramp / wheel chair lift.

- 00 Inside bus
- 01 Outside bus
- 10 Error
- 11 Not available

Bit Length: 2 bits
 Type: Measured
 Suspect Parameter Number: 1820
 Parameter Group Number: [65102]

spn1821 - Position of doors - Signal which indicates the actual position of the doors.

- 0000 At least 1 door is open
- 0001 Closing last door
- 0010 All doors closed
- 0011-1101 Not defined
- 1110 Error
- 1111 Not available

Bit Length: 4 bits
 Type: Measured
 Suspect Parameter Number: 1821
 Parameter Group Number: [65102]

spn1822 - Lift Axle 2 Position - Signal which indicates the position / load condition of lift axle / tag axle #2. Numbering of lift/tag axles starts at front axle.

- 00 Lift axle position down / tag axle laden
- 01 Lift axle position up / tag axle unladen
- 10 Error
- 11 Not available

Bit Length: 2 bits
 Type: Measured
 Suspect Parameter Number: 1822
 Parameter Group Number: [65114]

spn1823 - Rear Axle in Bumper Range - Signal which indicates that the vehicle height at the rear axle (SPNs 1723 and 1724) is within the bumper range.

- 00 Actual level out of bumper range
- 01 Actual level within bumper range
- 10 Error
- 11 Not available

Bit Length: 2 bits
 Type: Measured
 Suspect Parameter Number: 1823
 Parameter Group Number: [65114]

spn1824 - Front Axle in Bumper Range - Signal which indicates that the vehicle height at the front axle (SPNs 1721 and 1722) is within the bumper range.

- 00 Actual level out of bumper range
- 01 Actual level within bumper range
- 10 Error
- 11 Not available

Bit Length: 2 bits
 Type: Measured
 Suspect Parameter Number: 1824
 Parameter Group Number: [65114]

spn1825 - Suspension Remote control 2 - Signal which indicates that the suspension system is controlled by remote control #2. Remote control is an external unit to operate the suspension system.

- 00 Not active
- 01 Active
- 10 Error
- 11 Not available

Bit Length: 2 bits
 Type: Measured
 Suspect Parameter Number: 1825
 Parameter Group Number: [65114]

spn1826 - Suspension Remote Control 1 - Signal which indicates that the suspension system is controlled by remote control #1. Remote control is an external unit to operate the suspension system.

- 00 Not active
- 01 Active
- 10 Error
- 11 Not available

Bit Length: 2 bits

Type: Measured
 Suspect Parameter Number: 1826
 Parameter Group Number: [65114]

spn1827 - Suspension Control Refusal Information - Signal which indicates that the air suspension control cannot perform a request due to the operating conditions. It also provides a reason for the refusal.

- 0000 Actual request not refused
- 0001 Axle load limit reached (load transfer)
- 0010 Would exceed axle load limit (tag axle)
- 0011 Bogie differential not locked
- 0100 Above speed limit
- 0101 Below speed limit
- 0110 - 1101 Not defined
- 1110 Error
- 1111 Not available

Bit Length: 4 bits
 Type: Status
 Suspect Parameter Number: 1827
 Parameter Group Number: [65114]

spn1828 - Lift Axle 2 Position Command - Signal to command the position / load condition of lift / tag axle #2.

Numbering of lift/tag axles starts at front axle.

- 00 Lift axle position down / tag axle laden
- 01 Lift axle position up / tag axle unladen
- 10 Reserved
- 11 Don't care/take no action

Bit Length: 2 bits
 Type: Status
 Suspect Parameter Number: 1828
 Parameter Group Number: [53760]

spn1829 - Kneeling Command - Rear Axle - Command signal to activate the kneeling functionality at the rear axle of the vehicle.

- 00 Deactivate kneeling
- 01 Activate kneeling
- 10 Reserved
- 11 Don't care/take no action

Bit Length: 2 bits
 Type: Status
 Suspect Parameter Number: 1829
 Parameter Group Number: [53760]

spn1830 - Kneeling Command - Front Axle - Command signal to activate the kneeling functionality at the front axle of the vehicle

- 00 Deactivate kneeling
- 01 Activate kneeling
- 10 Reserved
- 11 Don't care/take no action

Bit Length: 2 bits
 Type: Status
 Suspect Parameter Number: 1830
 Parameter Group Number: [53760]

spn1831 - Electronic Shock Absorber Control Mode - Lift/Tag Axle - Signal which indicates the current mode of operation of the electronic shock absorber control at the lift/tag axle.

- 00 Normal operation dampers passive
- 01 Normal operation dampers active
- 10 Error
- 11 Not available

Bit Length: 2 bits
 Type: Measured
 Suspect Parameter Number: 1831
 Parameter Group Number: [65111]

spn1832 - Electronic Shock Absorber Control Mode - Rear Axle - Signal which indicates the current mode of operation of the electronic shock absorber control at the rear axle.

- 00 Normal operation dampers passive
- 01 Normal operation dampers active
- 10 Error
- 11 Not available

Bit Length: 2 bits
 Type: Measured
 Suspect Parameter Number: 1832
 Parameter Group Number: [65111]

spn1833 - Electronic Shock Absorber Control Mode - Front Axle - Signal which indicates the current mode of operation of the electronic shock absorber control at the front axle.

- 00 Normal operation dampers passive
- 01 Normal operation dampers active
- 10 Error
- 11 Not available

Bit Length: 2 bits
 Type: Measured
 Suspect Parameter Number: 1833
 Parameter Group Number: [65111]

spn1834 - Total Average Fuel Rate - Average fuel rate, equal to total fuel used divided by total engine hours, over the life of the engine

Data Length: 2 bytes
 Resolution: 0.05 L/h per bit , 0 offset
 Data Range: 0 to 3,212.75 L/h
 Type: Measured
 Suspect Parameter Number: 1834
 Parameter Group Number: [65101]

spn1835 - Total Average Fuel Economy - Average fuel economy, equal to total vehicle distance divided by total fuel used, over the life of the engine

Data Length: 2 bytes
 Resolution: 1/512 km/L per bit , 0 offset
 Data Range: 0 to 125.5 km/L
 Type: Measured

Suspect Parameter Number: 1835
 Parameter Group Number: [65101]

spn1836 - Trailer ABS Status - State signal which indicates that ABS in the trailer is actively controlling the brakes. A message is sent to the tractor from the trailer (i.e. by PLC). The receiving device in the tractor transfers this information to the J1939 network. At the beginning of power on the message is sent by the trailer to indicate if this status information is supported. Timeout of the trailer ABS active can be done by monitoring of the Trailer warning light information.

- 00 Trailer ABS Status Information Available But Not Active
- 01 Trailer ABS Active
- 10 Reserved
- 11 Trailer ABS Status Information Not Available or Parameter Not Supported

Bit Length: 2 bits
 Type: Status
 Suspect Parameter Number: 1836
 Parameter Group Number: [61441]

spn1837 - Convoy Driving Lamp Select - Black Out Convoy Driving Lamp Selection

- 00 Off
- 01 On
- 10 Reserved
- 11 Not Supported

Bit Length: 2 bits
 Type: Status
 Suspect Parameter Number: 1837
 Parameter Group Number: [65100]

spn1838 - Convoy Lamp Select - Black Out Convoy Lamp Selection

- 00 Off
- 01 On
- 10 Reserved
- 11 Not Supported

Bit Length: 2 bits
 Type: Status
 Suspect Parameter Number: 1838
 Parameter Group Number: [65100]

spn1839 - Front Black Out Marker Lamp Select - Front Black Out Marker Lamp Selection

- 00 Off
- 01 On
- 10 Reserved
- 11 Not Supported

Bit Length: 2 bits
 Type: Status
 Suspect Parameter Number: 1839
 Parameter Group Number: [65100]

spn1840 - Rear Black Out Marker Select - Rear Black Out Marker Selection

- 00 Off
- 01 On
- 10 Reserved
- 11 Not Supported

Bit Length: 2 bits
 Type: Status
 Suspect Parameter Number: 1840
 Parameter Group Number: [65100]

spn1841 - Black Out Brake/Stop Lamp Select - Black Out Brake/Stop Lamp Selection

00 Off
 01 On
 10 Reserved
 11 Not Supported

Bit Length: 2 bits
 Type: Status
 Suspect Parameter Number: 1841
 Parameter Group Number: [65100]

spn1842 - Black Out Work Lamp Select - Black Out Work Lamp Selection

00 Off
 01 On
 10 Reserved
 11 Not Supported

Bit Length: 2 bits
 Type: Status
 Suspect Parameter Number: 1842
 Parameter Group Number: [65100]

spn1843 - Night Vision Illuminator Select - Night Vision Illuminator Selection

00 Off
 01 On
 10 Reserved
 11 Not Supported

Bit Length: 2 bits
 Type: Status
 Suspect Parameter Number: 1843
 Parameter Group Number: [65100]

spn1844 - Operators Black Out Intensity Selection - Operators Selection of lamp intensity in black out mode. This parameter provides the operators selected illumination intensity as a percentage of available full scale. This parameter would be typically used as a dash or instrument cluster intensity adjustment.

Data Length: 1 byte
 Resolution: 0.4 %/bit , 0 offset
 Data Range: 0 to 100 %
 Type: Status
 Suspect Parameter Number: 1844
 Parameter Group Number: [65100]

spn1845 - Transmission Torque Limit - Parameter provided to the engine from the transmission as a torque limit to be invoked by the engine in the event that J1939 communication with the transmission is lost. The intention is to protect transmissions that use a continuous torque limit during torque converter mode or operation in specific lower gears, where stall or drivetrain torque may

reach levels higher than the gearbox capacity. If communication is lost during torque limited operation, unrestricted engine torque output could harm the transmission. It is recommended that engines use reception of the ETC#1 message as a transmission 'heartbeat'. In the event that the ETC#1 message is not received in a time period of 5 times its' broadcast rate (5 x 10 ms = 50 ms), the engine should invoke a torque limit holding the engine to less than or equal to the value of the Transmission Torque Limit parameter. The engine may release the limit when transmission-to-engine communication is re-established. A value of 0xFF00 to 0xFFFF indicates that no transmission torque limit is desired. It is expected that the engine will record this torque value in non-volatile memory and will include this in the engine configuration PGN as parameter Default Engine Torque Limit (SPN 1846) If the engine observes change in this parameter value on power-up, the engine should record the new value.

Data Length:	2 bytes
Resolution:	1 Nm/bit , 0 offset
Data Range:	0 to 64,255 Nm
Type:	Measured
Suspect Parameter Number:	1845
Parameter Group Number:	[65099]

spn1846 - Default Engine Torque Limit - Companion parameter to Transmission Torque Limit (SPN 1845). This 'echo' parameter provides confirmation to the transmission that the engine has received and will invoke the requested Transmission Torque Limit in the event that J1939 communication is lost between the two devices. If the engine supports this protection logic, the Default Engine Torque Limit parameter should be set equal to the Transmission Torque Limit parameter as received in the Transmission Configuration message (PGN 65250). Otherwise, a Default Engine Torque Limit value of FF00 to FFFF indicates that no default engine torque limit has been received or set. The intention is to protect transmissions that use a continuous torque limit during torque converter mode or operation in specific lower gears, where stall or drivetrain torque may reach levels higher than the gearbox capacity. If communication is lost during torque limited operation, unrestricted engine torque output could harm the transmission. It is recommended that engines use reception of the ETC#1 message as a transmission 'heartbeat'. In the event that the ETC#1 message is not received in a time period of 5 times its' broadcast rate (5 x 10 ms = 50 ms), the engine should invoke a torque limit holding the engine to less than or equal to the value of the Transmission Torque Limit parameter. The engine may release the limit when engine-to-transmission communication is re-established.

Data Length:	2 bytes
Resolution:	1 Nm/bit , 0 offset
Data Range:	0 to 64,255 Nm
Type:	Measured
Suspect Parameter Number:	1846
Parameter Group Number:	[65251]

spn1849 - Transmission Requested Range Display Flash State - State signal indicating a transmission request for the display of the Transmission Requested Range parameter (SPN 162) to flash or not to flash. The 'Transmission Requested Range Display Flash State' indicator can be utilized by (but not limited to) the shift console, instrument cluster, or cab display. Definition of the cause of this state is at the discretion of the transmission manufacturer. The flash period shall be 700 ms @ 50% duty cycle.

Transmission manufacturers may want to flash the Transmission Requested Range display depending on certain events. It could be because a gear could not be attained, or because fluid is low, etc. Indicator should be on for 350 ms and off for 350 ms.

Transmissions supporting both this parameter and the Transmission Requested Range Display Blank

State should treat the active states of these parameters as mutually exclusive; both parameters should not indicate "active" at the same time.

00 Inactive; Transmission Requested Range display should not be flashing

01 Active; Transmission Requested Range display should be flashing

10 Reserved

11 Take no action

Bit Length:	2 bits
Type:	Status

Suspect Parameter Number: 1849
 Parameter Group Number: [65098]

spn1850 - Transmission Requested Range Display Blank State - State signal indicating a transmission request for the display of the Transmission Requested Range parameter (SPN162) to be blanked or not blanked. The 'Transmission Requested Range Display Blank State' indicator can be utilized by (but not limited to) the shift console, instrument cluster, or cab display.

Definition of the cause of this state is at the discretion of the transmission manufacturer

Transmission manufacturers may want to blank the Transmission Requested Range display depending on certain events. Typically it is an indication of a shift selector problem.

Transmissions supporting both this parameter and the Transmission Requested Range Display Flash

State should treat the active states of these parameters as mutually exclusive; both parameters should not indicate "active" at the same time.

00 Inactive; Transmission Requested Range display should not be blanked

01 Active; Transmission Requested Range display should be blanked

10 Reserved

11 Take no action

Bit Length: 2 bits
 Type: Status
 Suspect Parameter Number: 1850
 Parameter Group Number: [65098]

spn1851 - Shift Inhibit Indicator - State signal indicating a transmission request for the Shift Inhibit Indicator to be active or inactive. The shift inhibit indicator can be of lamp or text form, located on (but not limited to) the shift console, instrument cluster, or cab display. Definition of the cause of the 'range inhibit' state is at the discretion of the transmission manufacturer.

Transmission manufacturers may want to indicate that they currently cannot make a requested shift. This could be due to inappropriate vehicle speed or other restrictions.

00 Inactive; shift is not inhibited

01 Active; shift is inhibited

10 Reserved

11 Take no action

Bit Length: 2 bits
 Type: Status
 Suspect Parameter Number: 1851
 Parameter Group Number: [65098]

spn1852 - Transmission Mode 1 - Indicates whether transmission mode 1 is enabled. Modes are manufacturer specific and are not necessarily mutually exclusive. See also 2536.

00 Disable

01 Enable

10 Reserved

11 Take no action

Bit Length: 2 bits
 Type: Status
 Suspect Parameter Number: 1852
 Parameter Group Number: [256]

spn1853 - Transmission Mode 2 - Indicates whether transmission mode 2 is enabled. Modes are manufacturer specific and are not necessarily mutually exclusive. See also SPN 2537.

00 Disable

01 Enable

10 Reserved

11 Take no action

Bit Length: 2 bits

Type: Status
 Suspect Parameter Number: 1853
 Parameter Group Number: [256]

spn1854 - Transmission Mode 3 - Indicates whether transmission mode 3 is enabled. Modes are manufacturer specific and are not necessarily mutually exclusive. See also SPN 2538.

- 00 Disable
- 01 Enable
- 10 Reserved
- 11 Take no action

Bit Length: 2 bits
 Type: Status
 Suspect Parameter Number: 1854
 Parameter Group Number: [256]

spn1855 - Transmission Mode 4 - Indicates whether transmission mode 4 is enabled. Modes are manufacturer specific and are not necessarily mutually exclusive. See also SPN 2539.

- 00 Disable
- 01 Enable
- 10 Reserved
- 11 Take no action

Bit Length: 2 bits
 Type: Status
 Suspect Parameter Number: 1855
 Parameter Group Number: [256]

spn1856 - Seat Belt Switch - State of switch used to determine if Seat Belt is buckled

- 00 NOT Buckled
- 01 OK - Seat Belt is buckled
- 10 Error - Switch state cannot be determined
- 11 Not Available

Bit Length: 2 bits
 Type: Measured
 Suspect Parameter Number: 1856
 Parameter Group Number: [57344]

spn1857 - Winch Oil Pressure Switch - State of switch used to determine if Winch Oil Pressure is above desired minimum

- 00 NOT OK- Oil pressure is too low
- 01 OK - Oil pressure is above minimum
- 10 Error - Switch state cannot be determined
- 11 Not Available

Bit Length: 2 bits
 Type: Measured
 Suspect Parameter Number: 1857
 Parameter Group Number: [65128]

spn2347 - High Beam Head Light Command - Command to activate or de-activate the tractor high beam head light lamps.

- 00 De-activate
- 01 Activate

10 Reserved
11 Don't Care

Bit Length: 2 bits
Type: Status
Suspect Parameter Number: 2347
Parameter Group Number: [65089]

spn2348 - High Beam Head Light Data - This parameter provides measured data from the tractor high beam head light lamps.

00 De-activate
01 Activate
10 Fault Detected
11 Not Available

Bit Length: 2 bits
Type: Measured
Suspect Parameter Number: 2348
Parameter Group Number: [65088]

spn2349 - Low Beam Head Light Command - Command to activate or de-activate the tractor low beam head light lamps.

00 De-activate
01 Activate
10 Reserved
11 Don't Care

Bit Length: 2 bits
Type: Status
Suspect Parameter Number: 2349
Parameter Group Number: [65089]

spn2350 - Low Beam Head Light Data - This parameter provides measured data from the tractor low beam head light lamps.

00 De-activate
01 Activate
10 Fault Detected
11 Not Available

Bit Length: 2 bits
Type: Measured
Suspect Parameter Number: 2350
Parameter Group Number: [65088]

spn2351 - Alternate Beam Head Light Command - Command to activate or de-activate the tractor alternate head lights (only low beam is available on alternate head lights). The alternate position lights are intended for use with loader and snow plows that tend to block the primary head lights.

00 De-activate
01 Activate
10 Reserved
11 Don't Care

Bit Length: 2 bits
Type: Status
Suspect Parameter Number: 2351
Parameter Group Number: [65089]

spn2352 - Alternate Beam Head Light Data - This parameter provides measured data from the tractor alternate beam head light lamps.

00 De-activate
01 Activate
10 Fault Detected
11 Not Available

Bit Length: 2 bits
Type: Measured
Suspect Parameter Number: 2352
Parameter Group Number: [65088]

spn2353 - Tractor Front Low Mounted Work Lights Command - Command to activate or de-activate the tractor front low mounted work lights.

00 De-activate
01 Activate
10 Reserved
11 Don't Care

Bit Length: 2 bits
Type: Status
Suspect Parameter Number: 2353
Parameter Group Number: [65089]

spn2354 - Tractor Front Low Mounted Work Lights - This parameter provides measured data from the tractor front low mounted work lights.

00 De-activate
01 Activate
10 Fault Detected
11 Not Available

Bit Length: 2 bits
Type: Measured
Suspect Parameter Number: 2354
Parameter Group Number: [65088]

spn2355 - Tractor Front High Mounted Work Lights Command - Command to activate or de-activate the tractor front high mounted work lights.

00 De-activate
01 Activate
10 Reserved
11 Don't Care

Bit Length: 2 bits
Type: Status
Suspect Parameter Number: 2355
Parameter Group Number: [65089]

spn2356 - Tractor Front High Mounted Work Lights - This parameter provides measured data from the tractor front high mounted work lights.

00 De-activate
01 Activate
10 Fault Detected
11 Not Available

Bit Length: 2 bits

Type: Measured
 Suspect Parameter Number: 2356
 Parameter Group Number: [65088]

spn2357 - Tractor Underside Mounted Work Lights Command - Command to activate or de-activate the tractor underside mounted work lights.

00 De-activate
 01 Activate
 10 Reserved
 11 Don't Care

Bit Length: 2 bits
 Type: Status
 Suspect Parameter Number: 2357
 Parameter Group Number: [65089]

spn2358 - Tractor Underside Mounted Work Lights - This parameter provides measured data from the tractor underside mounted work lights.

00 De-activate
 01 Activate
 10 Fault Detected
 11 Not Available

Bit Length: 2 bits
 Type: Measured
 Suspect Parameter Number: 2358
 Parameter Group Number: [65088]

spn2359 - Tractor Rear Low Mounted Work Lights Command - Command to activate or de-activate the tractor rear low mounted work lights.

00 De-activate
 01 Activate
 10 Reserved
 11 Don't Care

Bit Length: 2 bits
 Type: Status
 Suspect Parameter Number: 2359
 Parameter Group Number: [65089]

spn2360 - Tractor Rear Low Mounted Work Lights - This parameter provides measured data from the tractor rear low mounted work lights.

00 De-activate
 01 Activate
 10 Fault Detected
 11 Not Available

Bit Length: 2 bits
 Type: Measured
 Suspect Parameter Number: 2360
 Parameter Group Number: [65088]

spn2361 - Tractor Rear High Mounted Work Lights Command - Command to activate or de-activate the tractor rear high mounted work lights.

00 De-activate
 01 Activate
 10 Reserved
 11 Don't Care

Bit Length: 2 bits
 Type: Status
 Suspect Parameter Number: 2361
 Parameter Group Number: [65089]

spn2362 - Tractor Rear High Mounted Work Lights - This parameter provides measured data from the tractor rear high mounted work lights.

00 De-activated
 01 Activated
 10 Fault Detected
 11 Not Available

Bit Length: 2 bits
 Type: Measured
 Suspect Parameter Number: 2362
 Parameter Group Number: [65088]

spn2363 - Tractor Side Low Mounted Work Lights Command - Command to activate or de-activate the tractor side low mounted work lights.

00 De-activate
 01 Activate
 10 Reserved
 11 Don't Care

Bit Length: 2 bits
 Type: Status
 Suspect Parameter Number: 2363
 Parameter Group Number: [65089]

spn2364 - Tractor Side Low Mounted Work Lights - This parameter provides measured data from the tractor side low mounted work lights.

00 De-activated
 01 Activated
 10 Fault Detected
 11 Not Available

Bit Length: 2 bits
 Type: Measured
 Suspect Parameter Number: 2364
 Parameter Group Number: [65088]

spn2365 - Tractor Side High Mounted Work Lights Command - Command to activate or de-activate the tractor side high mounted work lights.

00 De-activate
 01 Activate
 10 Reserved
 11 Don't Care

Bit Length: 2 bits
 Type: Status
 Suspect Parameter Number: 2365
 Parameter Group Number: [65089]

spn2366 - Tractor Side High Mounted Work Lights - This parameter provides measured data from the tractor side high mounted work lights.

00 De-activated
01 Activated
10 Fault Detected
11 Not Available

Bit Length: 2 bits
Type: Measured
Suspect Parameter Number: 2366
Parameter Group Number: [65088]

spn2367 - Left Turn Signal Lights Command - Command to activate or de-activate left turn signal lights on the tractor and all connected implements

00 De-activate
01 Activate
10 Reserved
11 Don't Care

Bit Length: 2 bits
Type: Status
Suspect Parameter Number: 2367
Parameter Group Number: [65089]

spn2368 - Left Turn Signal Lights - This parameter provides measured data from the tractor and attached implement left turn signal lights.

00 De-activated
01 Activated
10 Fault Detected
11 Not Available

Bit Length: 2 bits
Type: Measured
Suspect Parameter Number: 2368
Parameter Group Number: [65088]

spn2369 - Right Turn Signal Lights Command - Command to activate or de-activate right turn signal lights on the tractor and all connected implements

00 De-activate
01 Activate
10 Reserved
11 Don't Care

Bit Length: 2 bits
Type: Status
Suspect Parameter Number: 2369
Parameter Group Number: [65089]

spn2370 - Right Turn Signal Lights - This parameter provides measured data from the tractor and attached implement right turn signal lights.

00 De-activated
01 Activated
10 Fault Detected
11 Not Available

Bit Length: 2 bits

Type: Measured
 Suspect Parameter Number: 2370
 Parameter Group Number: [65088]

spn2371 - Left Stop Light Command - Command to activate or de-activate the tractor and implement left stop lights

- 00 De-activate
- 01 Activate
- 10 Reserved
- 11 Don't Care

Bit Length: 2 bits
 Type: Status
 Suspect Parameter Number: 2371
 Parameter Group Number: [65089]

spn2372 - Left Stop Light - This parameter provides measured data from the tractor and attached implement left stop lights.

- 00 De-activated
- 01 Activated
- 10 Fault Detected
- 11 Not Available

Bit Length: 2 bits
 Type: Measured
 Suspect Parameter Number: 2372
 Parameter Group Number: [65088]

spn2373 - Right Stop Light Command - Command to activate or de-activate the tractor and implement right stop light

- 00 De-activate
- 01 Activate
- 10 Reserved
- 11 Don't Care

Bit Length: 2 bits
 Type: Status
 Suspect Parameter Number: 2373
 Parameter Group Number: [65089]

spn2374 - Right Stop Light - This parameter provides measured data from the tractor and attached implement right stop lights.

- 00 De-activated
- 01 Activated
- 10 Fault Detected
- 11 Not Available

Bit Length: 2 bits
 Type: Measured
 Suspect Parameter Number: 2374
 Parameter Group Number: [65088]

spn2375 - Center Stop Light Command - Command to activate or de-activate the tractor and implement center stop light

- 00 De-activate
- 01 Activate
- 10 Reserved
- 11 Don't Care

Bit Length: 2 bits

Type: Status
 Suspect Parameter Number: 2375
 Parameter Group Number: [65089]

spn2376 - Center Stop Light - This parameter provides measured data from the tractor and attached implement center stop lights.

00 De-activated
 01 Activated
 10 Fault Detected
 11 Not Available

Bit Length: 2 bits
 Type: Measured
 Suspect Parameter Number: 2376
 Parameter Group Number: [65088]

spn2377 - Tractor Marker Light Command - Command to activate or de-activate tractor and implement front position lights, rear red tail lights, side amber running lights, license plate lights and instrument and switch back lights.

00 De-activate
 01 Activate
 10 Reserved
 11 Don't Care

Bit Length: 2 bits
 Type: Status
 Suspect Parameter Number: 2377
 Parameter Group Number: [65089]

spn2378 - Tractor Marker Light - This parameter provides measured data from the tractor and attached implement marker lights, including front position lights, rear tail lights, side running lights, license plate lights and instruments and switch back lights.

00 De-activated
 01 Activated
 10 Fault Detected
 11 Not Available

Bit Length: 2 bits
 Type: Measured
 Suspect Parameter Number: 2378
 Parameter Group Number: [65088]

spn2379 - Implement Marker Light Command - Command to activate or de-activate implement front position lights, rear red tail lights, side amber running lights, license plate lights and instrument and switch back lights.

00 De-activate
 01 Activate
 10 Reserved
 11 Don't Care

Bit Length: 2 bits
 Type: Status
 Suspect Parameter Number: 2379
 Parameter Group Number: [65089]

spn2380 - Implement Marker Light - This parameter provides measured data from an attached implement marker lights, including front position lights, rear tail lights, side running lights, license plate lights and instruments and switch back lights.

00 De-activated
 01 Activated
 10 Fault Detected
 11 Not Available

Bit Length: 2 bits
 Type: Measured
 Suspect Parameter Number: 2380
 Parameter Group Number: [65088]

spn2381 - Tractor Clearance Light Command - Command to activate or de-activate the tractor high mounted clearance and center ID lights

00 De-activate
 01 Activate
 10 Reserved
 11 Don't Care

Bit Length: 2 bits
 Type: Status
 Suspect Parameter Number: 2381
 Parameter Group Number: [65089]

spn2382 - Tractor Clearance Light - This parameter provides measured data from the tractor high mounted clearance and center ID lights.

00 De-activated
 01 Activated
 10 Fault Detected
 11 Not Available

Bit Length: 2 bits
 Type: Measured
 Suspect Parameter Number: 2382
 Parameter Group Number: [65088]

spn2383 - Implement Clearance Light Command - Command to activate or de-activate the implement high mounted clearance and lights.

00 De-activate
 01 Activate
 10 Reserved
 11 Don't Care

Bit Length: 2 bits
 Type: Status
 Suspect Parameter Number: 2383
 Parameter Group Number: [65089]

spn2384 - Implement Clearance Light - This parameter provides measured data from an attached implement high mounted clearance lights.

00 De-activated
 01 Activated
 10 Fault Detected
 11 Not Available

Bit Length: 2 bits
 Type: Measured
 Suspect Parameter Number: 2384
 Parameter Group Number: [65088]

spn2385 - Rotating Beacon Light Command - Command to activate or de-activate slow moving vehicle indicator lights on tractor and/or implements. Activation of the slow moving vehicle lights implies that the controller should manipulate the lighting as appropriate to provide the slow moving vehicle lighting function.

- 00 De-activate
- 01 Activate
- 10 Reserved
- 11 Don't Care

Bit Length: 2 bits
 Type: Status
 Suspect Parameter Number: 2385
 Parameter Group Number: [65089]

spn2386 - Rotating Beacon Light - This parameter provides measured data from the beacon light on tractor or attached implements.

- 00 De-activated
- 01 Activated
- 10 Fault Detected
- 11 Not Available

Bit Length: 2 bits
 Type: Measured
 Suspect Parameter Number: 2386
 Parameter Group Number: [65088]

spn2387 - Tractor Front Fog Lights Command - Command to activate or de-activate tractor front fog lights.

- 00 De-activate
- 01 Activate
- 10 Reserved
- 11 Don't Care

Bit Length: 2 bits
 Type: Status
 Suspect Parameter Number: 2387
 Parameter Group Number: [65089]

spn2388 - Tractor Front Fog Lights - This parameter provides measured data from the tractor front fog lights.

- 00 De-activated
- 01 Activated
- 10 Fault Detected
- 11 Not Available

Bit Length: 2 bits
 Type: Measured
 Suspect Parameter Number: 2388
 Parameter Group Number: [65088]

spn2389 - Rear Fog Light Command - Command to activate or de-activate tractor or implement rear fog lights.

- 00 De-activate
- 01 Activate
- 10 Reserved
- 11 Don't Care

Bit Length: 2 bits
 Type: Status
 Suspect Parameter Number: 2389

Parameter Group Number: [65089]

spn2390 - Rear Fog Lights - This parameter provides measured data from the tractor and/or implement rear fog lights.

- 00 De-activated
- 01 Activated
- 10 Fault Detected
- 11 Not Available

Bit Length: 2 bits
 Type: Measured
 Suspect Parameter Number: 2390
 Parameter Group Number: [65088]

spn2391 - Back Up Light and Alarm Horn Command - Command to activate or de-activate the back up lights and/or associated alarm if required

- 00 De-activate
- 01 Activate
- 10 Reserved
- 11 Don't Care

Bit Length: 2 bits
 Type: Status
 Suspect Parameter Number: 2391
 Parameter Group Number: [65089]

spn2392 - Back Up Light and Alarm Horn - This parameter provides measured data from the back up lights and/or associated alarm.

- 00 De-activated
- 01 Activated
- 10 Fault Detected
- 11 Not Available

Bit Length: 2 bits
 Type: Measured
 Suspect Parameter Number: 2392
 Parameter Group Number: [65088]

spn2393 - Lighting Data Request Command - Command to provide a response of the light state

- 00 De-activate
- 01 Activate
- 10 Reserved
- 11 Don't Care

Bit Length: 2 bits
 Type: Status
 Suspect Parameter Number: 2393
 Parameter Group Number: [65089]

spn2394 - Implement Rear Work Light - This parameter provides measured data from the implement rear work lamps.

- 00 De-activate
- 01 Activate
- 10 Fault Detected
- 11 Not Available

Bit Length: 2 bits
 Type: Measured

Suspect Parameter Number: 2394
 Parameter Group Number: [65088]

spn2395 - Implement OEM Option 1 Light Command - Command to activate or de-activate an implement OEM option 1 light. This is provided to meet special needs on implements, such as tank inspection or filling lights.

- 00 De-activate
- 01 Activate
- 10 Reserved
- 11 Don't Care

Bit Length: 2 bits
 Type: Status
 Suspect Parameter Number: 2395
 Parameter Group Number: [65089]

spn2396 - Implement OEM Option 1 Light - This parameter provides measured data from the implement OEM option 1 light.

- 00 De-activate
- 01 Activate
- 10 Fault Detected
- 11 Not Available

Bit Length: 2 bits
 Type: Measured
 Suspect Parameter Number: 2396
 Parameter Group Number: [65088]

spn2397 - Implement OEM Option 2 Light Command - Command to activate or de-activate an implement OEM option 2 light. This is provided to meet special needs on implements, such as tank inspection or filling lights.

- 00 De-activate
- 01 Activate
- 10 Reserved
- 11 Don't Care

Bit Length: 2 bits
 Type: Status
 Suspect Parameter Number: 2397
 Parameter Group Number: [65089]

spn2398 - Implement OEM Option 2 Light - This parameter provides measured data from the implement OEM option 2 light.

- 00 De-activate
- 01 Activate
- 10 Fault Detected
- 11 Not Available

Bit Length: 2 bits
 Type: Measured
 Suspect Parameter Number: 2398
 Parameter Group Number: [65088]

spn2399 - Implement Left Forward Work Light Command - Command to activate or de-activate the forward facing work lights toward the left end of the implement.

- 00 De-activate
- 01 Activate

10 Reserved
11 Don't Care

Bit Length: 2 bits
Type: Status
Suspect Parameter Number: 2399
Parameter Group Number: [65089]

spn2400 - Implement Left Forward Work Light - This parameter provides measured data from the forward facing work lights toward the left end of the implement.

00 De-activate
01 Activate
10 Fault Detected
11 Not Available

Bit Length: 2 bits
Type: Measured
Suspect Parameter Number: 2400
Parameter Group Number: [65088]

spn2401 - Implement Right Forward Work Light Command - Command to activate or de-activate the forward facing work lights toward the right end of the implement.

00 De-activate
01 Activate
10 Reserved
11 Don't Care

Bit Length: 2 bits
Type: Status
Suspect Parameter Number: 2401
Parameter Group Number: [65089]

spn2402 - Implement Right Forward Work Light - This parameter provides measured data from the forward facing work lights toward the right end of the implement.

00 De-activate
01 Activate
10 Fault Detected
11 Not Available

Bit Length: 2 bits
Type: Measured
Suspect Parameter Number: 2402
Parameter Group Number: [65088]

spn2403 - Running Light Command - Command to activate or de-activate the tractor or powered vehicle running lights. Usually only used for on road vehicles.

00 De-activate
01 Activate
10 Reserved
11 Don't Care

Bit Length: 2 bits
Type: Status
Suspect Parameter Number: 2403
Parameter Group Number: [65089]

spn2404 - Running Light - This parameter provides measured data from the vehicle's running lights.

00 De-activate
01 Activate
10 Fault Detected
11 Not Available

Bit Length: 2 bits
Type: Measured
Suspect Parameter Number: 2404
Parameter Group Number: [65088]

spn2405 - Implement Rear Work Light Command - Command to activate or de-activate implement rear work lights.

(This is also the same as Reversing Lights for truck applications.)

00 De-activate
01 Activate
10 Reserved
11 Don't Care

Bit Length: 2 bits
Type: Status
Suspect Parameter Number: 2405
Parameter Group Number: [65089]

spn2406 - Implement Right Facing Work Light Command - Command to activate or de-activate work lights mounted on an implement to illuminate beyond right end of the implement.

00 De-activate
01 Activate
10 Reserved
11 Don't Care

Bit Length: 2 bits
Type: Status
Suspect Parameter Number: 2406
Parameter Group Number: [65089]

spn2407 - Implement Right Facing Work Light - This parameter provides measured data from the work lights mounted on an implement to illuminate beyond right end of the implement.

00 De-activate
01 Activate
10 Fault Detected
11 Not Available

Bit Length: 2 bits
Type: Measured
Suspect Parameter Number: 2407
Parameter Group Number: [65088]

spn2430 - Main Radiator/Engine Coolant Level - Indicator of coolant level in main radiator or engine. Coolant Level (SPN 111) should be used if coolant expansion tank is being monitored.

spn2432 - Engine Demand - Percent Torque - The requested torque output of the engine by all dynamic internal inputs, including smoke control, noise control and low and high speed governing.

Data Length: 1 byte
Resolution: 1 %/bit , -125% offset

Data Range:	-125 to 125 %
Operating Range:	-125% to +125%
Type:	Measured
Suspect Parameter Number:	2432
Parameter Group Number:	[61444]

Background:

During periods of TSC1 engine control, other devices on the J1939 network may wish to know where the engine wants to go once it is released from TSC1 control. In order for option transitions of driveline torque between different devices, it becomes necessary to understand the engine's desired torque for all phases of a TSC1 control sequence.

Driver's Demand Engine – Percent Torque (SPN 512) provides a partial prediction of the torque the engine wishes to produce after a TSC1 command is removed. Included in Driver's Demand Torque (DDT) are external requestors to the powertrain such as accelerator pedal, cruise control, and road speed limit governors. However, excluded from DDT are (1) dynamic commands within the powertrain such as smoke control, noise control, and low and high speed engine governing, and (2) external TSC1 commands to the engine such as those generated by traction control.

For a controller to properly determine the engine's desired output torque during a TSC1 sequence, it needs knowledge of the torque being scheduled by all active controls within the engine. Since DDT excludes many of these active controllers from its calculation, it cannot be used to accurately predict the desired output torque. The effects of the external TSC1 commands can be approximated by other devices by means of monitoring TSC1 messages to the engine; however the effects of the engine's internal dynamic commands are completely unknown and cannot be estimated.

Actual Engine – Percent Torque (SPN 513) provides a window to the engine's desired torque output when no TSC1 commands are actively controlling the engine. However, when the engine is responding to TSC1 commands, the Actual Engine – Percent Torque parameter is no longer indicative of the torque that the engine will produce once those TSC1 commands are removed.

In simplest terms, Engine Demand – Percent Torque (or "EDT") contains the engine's internal dynamic commands that are excluded from the Driver's Demand Engine – Percent Torque definition, including smoke control, noise control, and low and high speed governing. With this additional piece of information, devices on the network that are controlling the engine via TSC1 messages can determine the torque direction of the engine once the current TSC1 command is relinquished.

It is important to note that the proposed EDT parameter is used as information. The addition of the EDT parameter should in no way cause a change to the engine's actual torque command architecture.

EDT Calculation:

When no devices are controlling the engine via TSC1 messages, the value of EDT is equal to the Actual Engine – Percent Torque parameter. When the engine is being controlled via a TSC1 message, it is necessary for the engine controller to calculate what its target torque would be if there were no external commands being received. This "runner up" in engine control will come from internal dynamic engine commands.

In the calculation of Actual Engine – Percent Torque, the output of the engine's idle governor must be considered, along with the impact of the engine's full load governor, smoke controls and other internal limiting logic. In the determination of the Engine Demand Torque parameter, these same engine logic components are needed, as indicated in Figure SPN 2432_A. However, there is a significant difference: These components only affect the Actual Engine – Percent Torque parameter determination if they are the component actively controlling the engine. In EDT, any of these components will be used to calculate EDT if they are the "runner up" for engine control. Even though these components may lose in the engine's internal control arbitration, the engine output torque that they would produce if in command needs to be found to determine EDT.

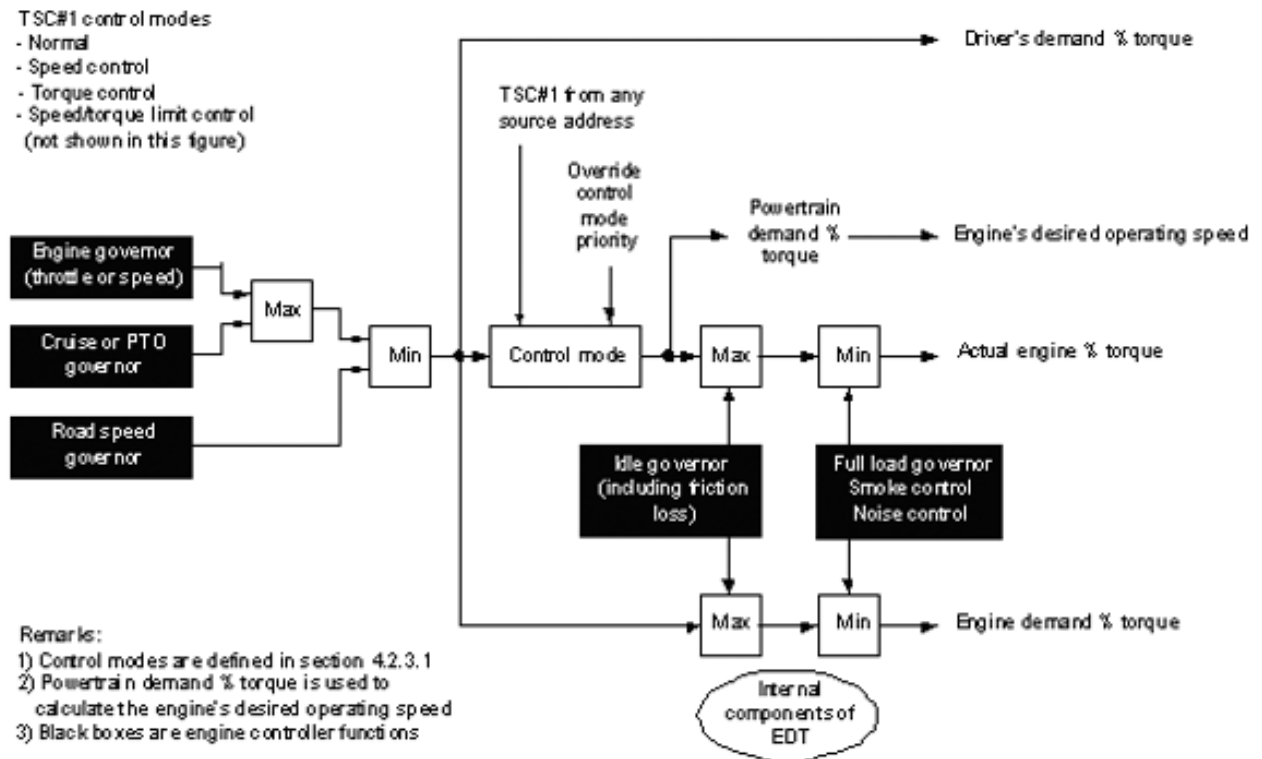

FIGURE SPN 2432_A – TORQUE COMMANDS AND CALCULATIONS WHEN A "MAXIMUM LOWIDLE" TECHNIQUE IS USED

If speed governors are involved in determining these components of the EDT calculation, any of the following 3 special cases may need to be addressed:

Special Case #1: Speed Governors

If the engine governor referenced in Figure SPN 2432_A is a speed-based governor instead of a throttle table arrangement, a new challenge is presented in determining EDT. Since the speed governor output is directly influenced by the TSC1 command in control (for example, integrator anti-windup logic), the speed governor's output during TSC1 commands cannot be used to calculate EDT.

Instead, an approximation of the speed governor output without the effects of any TSC1 commands is required for use in the EDT calculation. "Approximation" refers to removing the effects of integrator terms and any other dynamic components that result from the controlling TSC1 commands. All elements affecting the speed governor reference should be included before the reference is translated into terms of torque.

All control algorithms with dynamic elements (e.g., speed governors) that execute during TSC1 commands need to have their outputs replaced by "steady-state" approximations for use in the EDT calculation. Again note that these approximations are for use only in the EDT calculation; the actual engine control logic remains unchanged.

Figure SPN 2432_B illustrates EDT and speed governor output during a typical control sequence. The output of the speed governor may tend to lag the engine's torque trace during and after the TSC1 command sequence. Note however that the TSC1's influence is not factored into EDT; only when the command sequence ends or is no longer winning in terms of engine control arbitration do the dynamic effects of the speed governor(s) appear in the EDT signal.

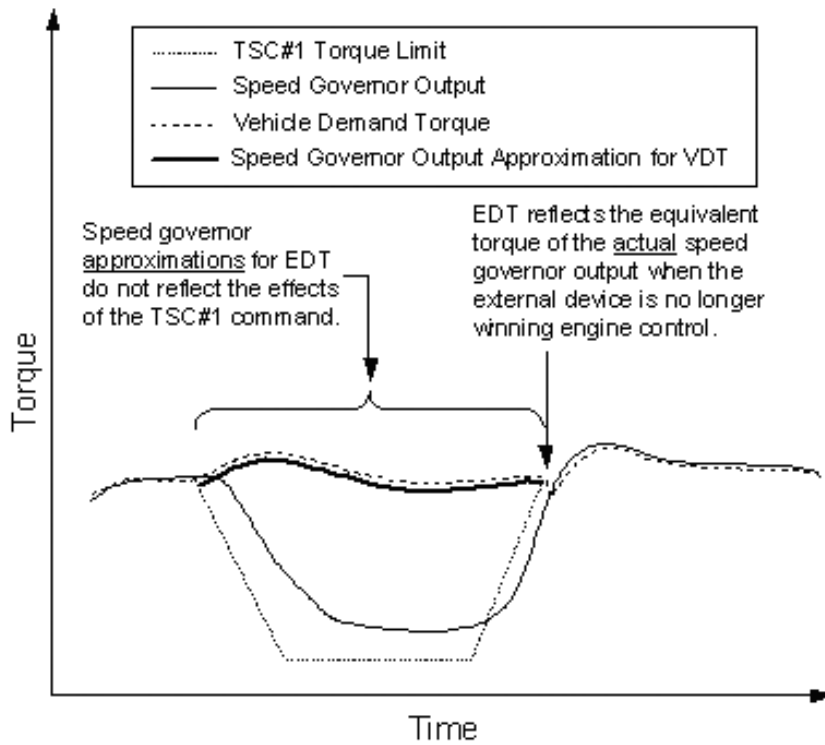

FIGURE SPN2432_B - EDT AND SPEED GOVERNOR OUTPUT RELATIONSHIP DURING A CONTROL SEQUENCE

One method of converting the speed governor reference to torque is shown in Figure SPN 2432_C. The inputs of current engine speed, accelerator pedal position and the shape of the governor droop curves can be used to find the equivalent torque output of the governor. A lookup table or calculation could be used.

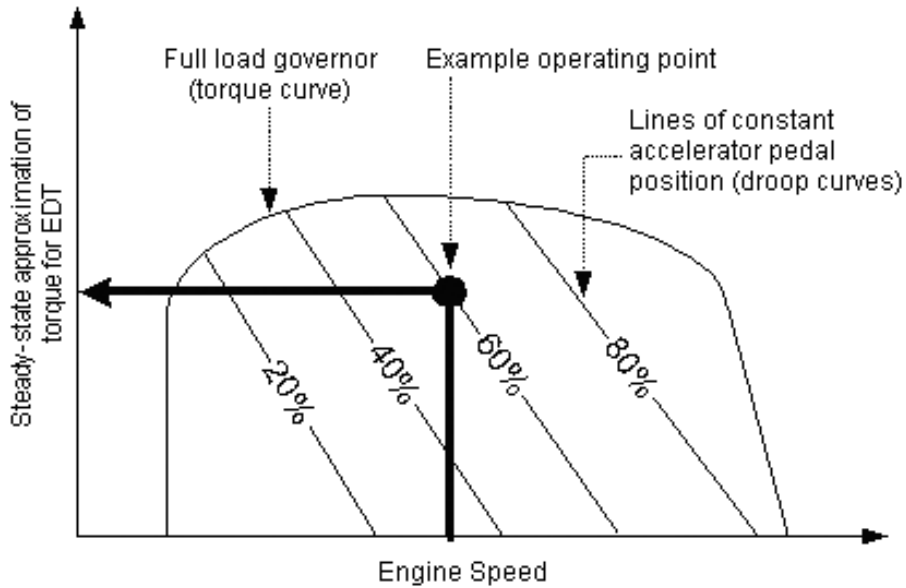

FIGURE SPN2432_C - FINDING EDT TORQUE APPROXIMATION FOR A SPEED GOVERNOR

Special Case #2: "Steep" or zero droop speed governors

Using a steady-state approximation with a "steep" or zero droop speed governor can cause large EDT changes over small speed changes. For example, if a cruise control governor has a zero droop and the vehicle speed is just below the cruise set speed, the steady-state torque approximation using the method described previously is very large. If vehicle speed increases a small amount to above the cruise set speed, the steady-state torque approximation becomes very small or zero.

As a result, a more accurate steady-state torque approximation is needed when steep droop governors are involved. A steep droop speed governor is defined as having a droop slope greater than 0.2% actual torque per rpm as seen below in Figure SPN 2432_D.

The following method can be used to determine a steady-state torque approximation for steep or zero droop governors with fast responding integrator anti-windup / integrator resetting:

1. Upon a TSC1 message actively controlling engine torque, save the last value of torque commanded by the speed governor (τ_{SG0}) and the last value of speed governor error (ϵ_{SG0}).
2. During this control sequence, calculate speed governor error (ϵ_{SGi})
3. Calculate an estimated torque for EDT determination use:

$$\tau_{SG\text{estimated}} = \tau_{SG0} + Kp_{SG} * (\epsilon_{SG0} - \epsilon_{SGi})$$

where Kp_{SG} is the speed governor proportional gain

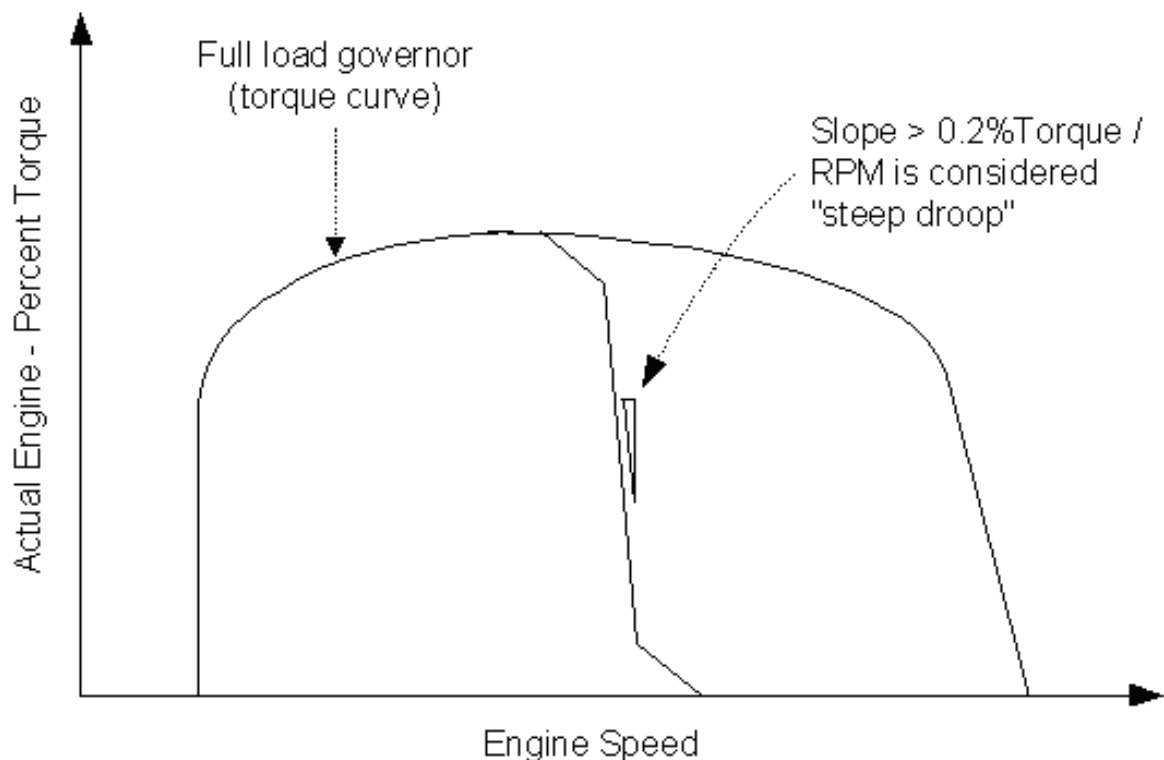

FIGURE SPN2432_D - EXAMPLE OF "STEEP DROOP" SPEED GOVERNOR

Special Case #3: "Slow Response" Speed Governors

If the speed governor dynamic elements are slow to respond to a 1 second torque derate, then the speed governor can simply be executed during the TSC1 event and the output used directly in determining EDT. This is an alternative for a speed governor which does not contain an integrator, or if the integrator anti-windup logic is slow to respond. A guideline for "slow response" is that the governor output after 1 second of torque limiting has only moved 1/3 of the way to the limit, as shown for example in Figure SPN 2432_E.

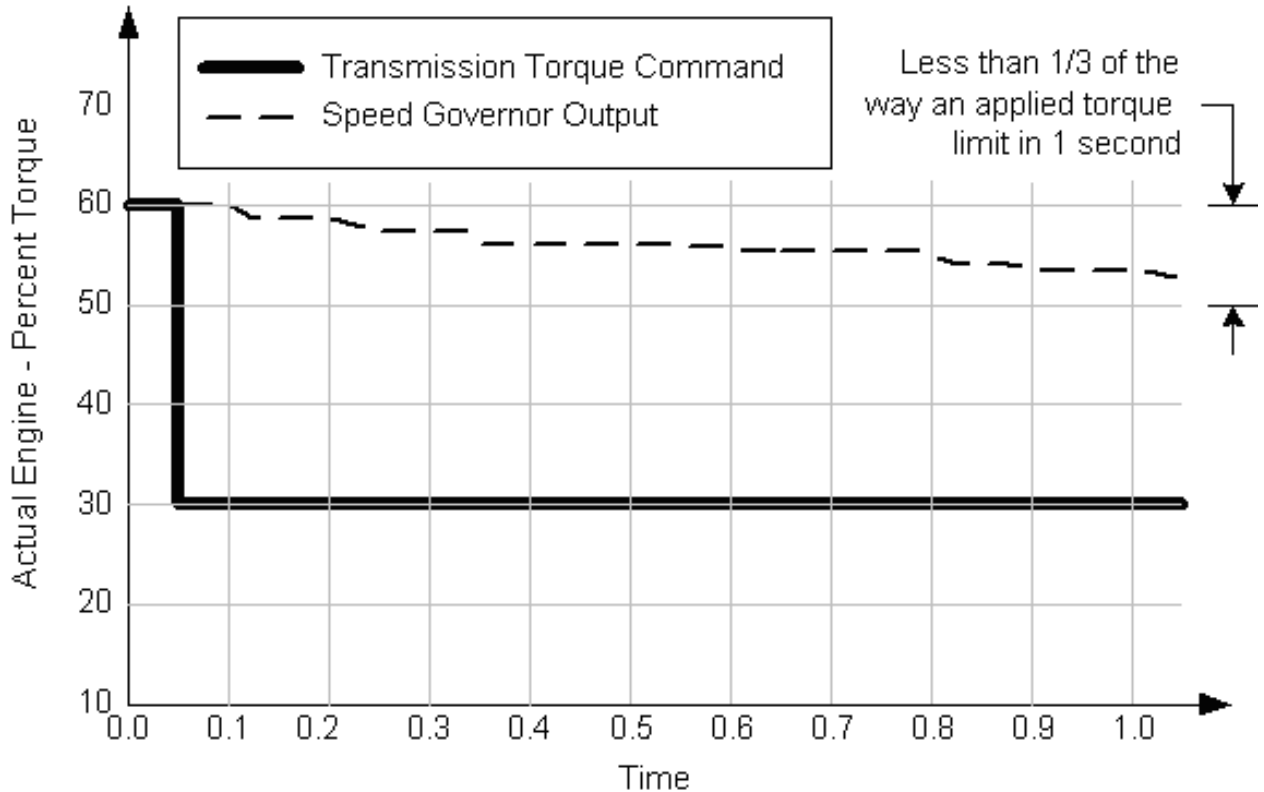

FIGURE SPN2432_E - EXAMPLE OF "SLOW TO RESPOND" SPEED GOVERNOR

spn2433 - Right Manifold Exhaust Gas Temperature - Temperature of combustion byproducts within the right engine exhaust manifold. Single manifold engines should use exhaust temperature (SPN 173).

Data Length: 2 bytes
 Resolution: 0.03125 deg C/bit , -273 deg C offset
 Data Range: -273 to 1735 deg C
 Type: Measured
 Suspect Parameter Number: 2433
 Parameter Group Number: [65031]

spn2434 - Left Manifold Exhaust Gas Temperature - Temperature of combustion byproducts within the left engine exhaust manifold. Single manifold engines should use exhaust temperature (SPN 173).

Data Length: 2 bytes
 Resolution: 0.03125 deg C/bit , -273 deg C offset

Data Range: -273 to 1735 deg C
 Type: Measured
 Suspect Parameter Number: 2434
 Parameter Group Number: [65031]

spn2435 - Sea Water Pump Outlet Pressure - Gauge pressure of liquid found at outlet of sea water pump in sea water cooling system.

Data Length: 1 byte
 Resolution: 2 kPa/bit , 0 offset
 Data Range: 0 to 500 kPa
 Type: Measured
 Suspect Parameter Number: 2435
 Parameter Group Number: [65172]

spn2536 - Transmission Mode 1 Indicator - This state signal is the transmission's indication that it is operating under transmission mode 1 (SPN 1852) as commanded via the TC1 message (PGN 256). The definition of the transmission mode is left to the discretion of the transmission manufacturer.

- 00 Transmission Mode 1 not active
- 01 Transmission Mode 1 Active
- 10 Error
- 11 Not available

Bit Length: 2 bits
 Type: Status
 Suspect Parameter Number: 2536
 Parameter Group Number: [65098]

spn2537 - Transmission Mode 2 Indicator - This state signal is the transmission's indication that it is operating under transmission mode 2 (SPN 1853) as commanded via the TC1 message (PGN 256). The definition of the transmission mode is left to the discretion of the transmission manufacturer.

- 00 Transmission Mode 2 not active
- 01 Transmission Mode 2 Active
- 10 Error
- 11 Not available

Bit Length: 2 bits
 Type: Status
 Suspect Parameter Number: 2537
 Parameter Group Number: [65098]

spn2538 - Transmission Mode 3 Indicator - This state signal is the transmission's indication that it is operating under transmission mode 3 (SPN 1854) as commanded via the TC1 message (PGN 256). The definition of the transmission mode is left to the discretion of the transmission manufacturer.

- 00 Transmission Mode 3 not active
- 01 Transmission Mode 3 Active
- 10 Error
- 11 Not available

Bit Length: 2 bits
 Type: Status
 Suspect Parameter Number: 2538
 Parameter Group Number: [65098]

spn2539 - Transmission Mode 4 Indicator - This state signal is the transmission's indication that it is operating under transmission mode 4 (SPN 1855) as commanded via the TC1 message (PGN 256). The definition of the transmission mode is left to the discretion of the transmission manufacturer.

- 00 Transmission Mode 4 not active
- 01 Transmission Mode 4 Active
- 10 Error
- 11 Not available

Bit Length: 2 bits
 Type: Status
 Suspect Parameter Number: 2539
 Parameter Group Number: [65098]

spn2576 - Laser Receiver Type - Identifies which type of Laser Receiver transmitted the message.

- 0 = Reserved
- 1 = Linear Laser Receiver
- 2 = 1 Meter Survey Receiver
- 3 = 2 Meter Survey Receiver
- 4 = 2.5 Meter Survey Receiver
- 5-250 = Reserved

Data Length: 1 byte
 Resolution: 1 count/bit , 0 offset
 Data Range: 0 to 250
 Operating Range: 1-4
 Type: Status
 Suspect Parameter Number: 2576
 Parameter Group Number: [65141]

spn2577 - Display Deadbands - Sets Display Deadbands mode.

- 0000 - Narrow = +/- 4.5mm
- 0001 - Standard = +/- 12mm
- 0010 - Wide = +/- 24mm
- 0011 - 1110 Reserved
- 1111 Not Available

Bit Length: 4 bits
 Type: Status
 Suspect Parameter Number: 2577
 Parameter Group Number: [65142]

spn2578 - LED Pattern Control - Sets LED Pattern control mode on laser leveling systems.

- 0000 - 5 Channel
- 0001 - Offset
- 0010 - 7 Channel
- 0011 - 1110 Reserved
- 1111 Not Available

Bit Length: 4 bits
 Type: Status
 Suspect Parameter Number: 2578
 Parameter Group Number: [65142]

spn2579 - Net Battery Current (High Range/Resolution) - Net flow of electrical current into/out-of the battery or batteries. This parameter is the high range and resolution of SPN 114 - Net Battery Current.

Data Length: 2 bytes
 Resolution: 0.05 A/bit , -1600 A offset
 Data Range: -1600 to 1612.75 A
 Type: Measured
 Suspect Parameter Number: 2579
 Parameter Group Number: [65106]

spn2580 - Hydraulic Brake Pressure Circuit 1 - Gage hydraulic pressure in circuit 1 of the hydraulic brake system

Data Length: 1 byte
 Resolution: 100 kPa/bit , 0 offset
 Data Range: 0 to 25 MPa
 Type: Measured
 Suspect Parameter Number: 2580
 Parameter Group Number: [64998]

spn2581 - Hydraulic Brake Pressure Circuit 2 - Gage hydraulic pressure in circuit 2 of the hydraulic brake system

Data Length: 1 byte
 Resolution: 100 kPa/bit , 0 offset
 Data Range: 0 to 25 MPa
 Type: Measured
 Suspect Parameter Number: 2581
 Parameter Group Number: [64998]

spn2582 - Hydraulic Brake Pressure Supply State Circuit 1 - Signal which indicates whether the hydraulic brake pressure supply of circuit 1 is reliable; that is, able to support continued braking.

00 Supply is not reliable
 01 Supply is reliable
 10 Error indicator
 11 Not available

Bit Length: 2 bits
 Type: Measured
 Suspect Parameter Number: 2582
 Parameter Group Number: [64998]

spn2583 - Hydraulic Brake Pressure Supply State Circuit 2 - Signal which indicates whether the hydraulic brake pressure supply of circuit 2 is reliable; that is, able to support continued braking.

00 Supply is not reliable
 01 Supply is reliable
 10 Error indicator
 11 Not available

Bit Length: 2 bits
 Type: Measured
 Suspect Parameter Number: 2583
 Parameter Group Number: [64998]

spn2584 - Hydraulic Brake Pressure Warning State Circuit 1 - Signal which indicates whether the hydraulic brake pressure of circuit 1 is below the warning level

00 Pressure level sufficient
 01 Pressure level below warning level
 10 Error indicator
 11 Not available

Bit Length: 2 bits
 Type: Measured
 Suspect Parameter Number: 2584
 Parameter Group Number: [64998]

spn2585 - Hydraulic Brake Pressure Warning State Circuit 2 - Signal which indicates whether the hydraulic brake pressure of circuit 2 is below the warning level

00 Pressure level sufficient
 01 Pressure level below warning level
 10 Error indicator
 11 Not available

Bit Length: 2 bits
 Type: Measured
 Suspect Parameter Number: 2585
 Parameter Group Number: [64998]

spn2586 - Tire Air Leakage Rate - The pressure loss rate of a tire.

Data Length: 2 bytes
 Resolution: 0.1 Pa/s per bit , 0 offset
 Data Range: 0 Pa/s to 6425.5 Pa/s
 Type: Measured
 Suspect Parameter Number: 2586
 Parameter Group Number: [65268]

spn2587 - Tire Pressure Threshold Detection - Signal indicating the pressure level of the tire. The levels defined represent different pressure conditions of the tire:

000 Extreme over pressure - The tire pressure is at a level where the safety of the vehicle may be jeopardised.
 001 Over pressure - The tire pressure is higher than the pressure defined by the vehicle or tire manufacturer.
 010 No warning pressure - The tire pressure is within the thresholds defined by the vehicle or tire manufacturer.
 011 Under pressure - The tire pressure is lower than the pressure defined by the vehicle or tire manufacturer.
 100 Extreme under pressure - The tire pressure is at a level where the safety of the vehicle may be jeopardised.
 101 Not defined
 110 Error indicator
 111 Not available

Bit Length: 3 bits
 Type: Measured
 Suspect Parameter Number: 2587
 Parameter Group Number: [65268]

spn2588 - Maximum Vehicle Speed Limit 1 - The lowest Maximum Vehicle Speed Limit. This value is the similar to SPN 74. However, SPN 74 was not specifically defined to convey the applied vehicle speed limit or what was possible to be applied. This new SPN is the lowest vehicle speed limit that is possible. Additionally, the lowest vehicle speed limit shall be applied when the J1939 network is no longer providing input regarding the Selected Maximum Vehicle Speed Limit. Exceptions to this exist when the device performing the maximum vehicle speed limiting function has methods of selecting the thresholds separately from the Selected Maximum Vehicle Speed Limit parameter.

Data Length: 1 byte

Resolution: 1 km/h per bit , 0 offset
 Data Range: 0 to 250 km/h
 Type: Status
 Suspect Parameter Number: 2588
 Parameter Group Number: [64997]

spn2589 - Maximum Vehicle Speed Limit 2 - The highest of the two lowest vehicle speed limits

Data Length: 1 byte
 Resolution: 1 km/h per bit , 0 offset
 Data Range: 0 to 250 km/h
 Type: Status
 Suspect Parameter Number: 2589
 Parameter Group Number: [64997]

spn2590 - Maximum Vehicle Speed Limit 3 - The highest of the three lowest vehicle speed limits

Data Length: 1 byte
 Resolution: 1 km/h per bit , 0 offset
 Data Range: 0 to 250 km/h
 Type: Status
 Suspect Parameter Number: 2590
 Parameter Group Number: [64997]

spn2591 - Maximum Vehicle Speed Limit 4 - The highest of the four lowest vehicle speed limits

Data Length: 1 byte
 Resolution: 1 km/h per bit , 0 offset
 Data Range: 0 to 250 km/h
 Type: Status
 Suspect Parameter Number: 2591
 Parameter Group Number: [64997]

spn2592 - Maximum Vehicle Speed Limit 5 - The highest of the five lowest vehicle speed limits

Data Length: 1 byte
 Resolution: 1 km/h per bit , 0 offset
 Data Range: 0 to 250 km/h
 Type: Status
 Suspect Parameter Number: 2592
 Parameter Group Number: [64997]

spn2593 - Maximum Vehicle Speed Limit 6 - The highest of the six lowest vehicle speed limits

Data Length: 1 byte
 Resolution: 1 km/h per bit , 0 offset
 Data Range: 0 to 250 km/h
 Type: Status
 Suspect Parameter Number: 2593

Parameter Group Number: [64997]

spn2594 - Maximum Vehicle Speed Limit 7 - The highest of the seven lowest vehicle speed limits

Data Length: 1 byte
 Resolution: 1 km/h per bit , 0 offset
 Data Range: 0 to 250 km/h
 Type: Status
 Suspect Parameter Number: 2594
 Parameter Group Number: [64997]

spn2595 - Applied Vehicle Speed Limit - The vehicle speed limit in effect.

Data Length: 1 byte
 Resolution: 1 km/h per bit , 0 offset
 Data Range: 0 to 250 km/h
 Type: Status
 Suspect Parameter Number: 2595
 Parameter Group Number: [64997]

spn2596 - Selected Maximum Vehicle Speed Limit - User selected maximum vehicle speed, must equal one of the maximum vehicle speeds #1-#7 from PGN 64997 - maximum vehicle speed limit status . If different maximum vehicle speed requests are present from different devices, the lowest requested value should be used.

Data Length: 1 byte
 Resolution: 1 count/bit , 0 offset
 Data Range: 0 to 250
 Operating Range: 1 through 7 are allowed. 8 through 250 are not allowed.
 Type: Status
 Suspect Parameter Number: 2596
 Parameter Group Number: [57344]

spn2597 - Implement Left Facing Work Light Command - Command to activate or de-activate work lights mounted on an implement to illuminate beyond left end of the implement.

- 00 De-activate
- 01 Activate
- 10 Reserved
- 11 Don't Care

Bit Length: 2 bits
 Type: Status
 Suspect Parameter Number: 2597
 Parameter Group Number: [65089]

spn2598 - Implement Left Facing Work Light - This parameter provides measured data from the work lights mounted on an implement to illuminate beyond left end of the implement.

- 00 De-activate
- 01 Activate
- 10 Fault Detected
- 11 Not Available

Bit Length: 2 bits

Type: Measured
 Suspect Parameter Number: 2598
 Parameter Group Number: [65088]

spn2599 - Fire Apparatus Pump Engagement - The measured status of the pump used to provide water in fire fighting apparatus for distribution of water through water cannons or fire hoses.

00 Pump not engaged
 01 Pump engaged
 10 Error
 11 Not available or not installed

Bit Length: 2 bits
 Type: Measured
 Suspect Parameter Number: 2599
 Parameter Group Number: [61448]

spn2600 - Payload Percentage - The current payload of the equipment, reported as a percentage of the equipment's rated payload limit.

Data Length: 1 byte
 Resolution: 1 %/bit , 0 offset
 Data Range: 0 to 250 %
 Type: Measured
 Suspect Parameter Number: 2600
 Parameter Group Number: [64996]

spn2601 - Travel Velocity Control Position - The position of the travel velocity control component reported as a percentage of the control's full displacement in each direction respectively. Positive position values indicate forward travel direction; negative position values indicate reverse, or backward, travel direction; and zero (0) percent position indicates the control device is in the neutral position. Higher percent for a particular travel direction indicates a higher desired travel speed in that direction.

Data Length: 1 byte
 Resolution: 1 %/bit , -125% offset
 Data Range: -125 to 125 %
 Type: Measured
 Suspect Parameter Number: 2601
 Parameter Group Number: [64995]

spn2602 - Hydraulic Oil Level - This parameter indicates the level of the hydraulic fluid in tank as a ratio of current volume to total tank volume. This parameter is intended for reporting the hydraulic fluid level in the system tank or reservoir. This hydraulic fluid is for the entire hydraulics system of a piece of equipment.

Data Length: 1 byte
 Resolution: 0.4 %/bit , 0 offset
 Data Range: 0 to 100 %
 Type: Measured
 Suspect Parameter Number: 2602
 Parameter Group Number: [65128]

spn2603 - Pneumatic Supply Pressure Request - Command signal to influence the pneumatic pressure in the main

reservoir. This parameter is the setpoint for the parameter SPN 46.

Data Length:	1 byte
Resolution:	8 kPa/bit , 0 offset
Data Range:	0 to 2,000 kPa
Type:	Status
Suspect Parameter Number:	2603
Parameter Group Number:	[64994]

spn2604 - Parking and/or Trailer Air Pressure Request - Command signal to influence the pneumatic pressure in the circuit or reservoir for the parking brake and/or the trailer supply. This parameter is the setpoint for the parameter SPN 1086.

Data Length:	1 byte
Resolution:	8 kPa/bit , 0 offset
Data Range:	0 to 2,000 kPa
Type:	Status
Suspect Parameter Number:	2604
Parameter Group Number:	[64994]

spn2605 - Service Brake Air Pressure Request, Circuit #1 - Command signal to influence the pneumatic pressure in the service brake circuit or reservoir #1. This parameter is the setpoint for the parameter SPN 1087.

Data Length:	1 byte
Resolution:	8 kPa/bit , 0 offset
Data Range:	0 to 2,000 kPa
Type:	Status
Suspect Parameter Number:	2605
Parameter Group Number:	[64994]

spn2606 - Service Brake Air Pressure Request, Circuit #2 - Command signal to influence the pneumatic pressure in the service brake circuit or reservoir #2. This parameter is the setpoint for the parameter SPN 1088.

Data Length:	1 byte
Resolution:	8 kPa/bit , 0 offset
Data Range:	0 to 2,000 kPa
Type:	Status
Suspect Parameter Number:	2606
Parameter Group Number:	[64994]

spn2607 - Auxiliary Equipment Supply Pressure Request - Command signal to influence the pneumatic pressure in the auxiliary circuit. This parameter is the setpoint for the parameter SPN 1089.

Data Length:	1 byte
Resolution:	8 kPa/bit , 0 offset
Data Range:	0 to 2,000 kPa
Type:	Status
Suspect Parameter Number:	2607
Parameter Group Number:	[64994]

spn2608 - Air Suspension Supply Pressure Request - Command signal to influence the pneumatic pressure in the circuit for the electronically controlled air suspension system. This parameter is the setpoint for the parameter SPN 1090.

Data Length: 1 byte
 Resolution: 8 kPa/bit , 0 offset
 Data Range: 0 to 2,000 kPa
 Type: Status
 Suspect Parameter Number: 2608
 Parameter Group Number: [64994]

spn2609 - Cab A/C Refrigerant Compressor Outlet Pressure - This is the gage pressure at the compressor outlet in the cab air conditioning system.

Data Length: 1 byte
 Resolution: 16 kPa/bit , 0 offset
 Data Range: 0 to 4000 kPa
 Type: Measured
 Suspect Parameter Number: 2609
 Parameter Group Number: [64993]

spn2610 - Solar Intensity Percent - This is the solar radiation (power density) falling on the vehicle in percent of the maximum sensor value (SPN 2611). Currently this is in the infra-red spectrum.

Data Length: 1 byte
 Resolution: 0.4 %/bit , 0 offset
 Data Range: 0 to 100 %
 Type: Measured
 Suspect Parameter Number: 2610
 Parameter Group Number: [64992]

spn2611 - Solar Sensor Maximum - This is the maximum value which can be reported by the sensor for the solar intensity. (This is a configuration parameter)

Data Length: 1 byte
 Resolution: 0.4 mW/cm² per bit , 0 offset
 Data Range: 0 to 100 mW/cm²
 Type: Status
 Suspect Parameter Number: 2611
 Parameter Group Number: [64992]

spn2612 - Front Wheel Drive Actuator Status - Feedback on the front wheel drive actuator.

- 00 Front Wheel Drive Actuator not engaged
- 01 Front Wheel Drive Actuator engaged
- 10 Error
- 11 Not Available

Bit Length: 2 bits
 Type: Measured
 Suspect Parameter Number: 2612
 Parameter Group Number: [64991]

spn2613 - Drive Axle Lube Pressure - The drive axle lubricant pressure with location determined by Drive Axle Location (SPN 930).

Data Length: 1 byte
 Resolution: 4 kPa/bit , 0 offset
 Data Range: 0 to 1000 kPa
 Type: Measured
 Suspect Parameter Number: 2613
 Parameter Group Number: [65273]

spn2614 - Steering Axle Lube Pressure - The steering axle lubricant pressure.

Data Length: 1 byte
 Resolution: 4 kPa/bit , 0 offset
 Data Range: 0 to 1000 kPa
 Type: Measured
 Suspect Parameter Number: 2614
 Parameter Group Number: [65273]

spn2615 - Throttle Synchronization Mode Status - The status of the Throttle Synchronization Mode. Throttle Synchronization Mode is used to indicate which throttle, if any, is currently being used for the synchronized throttle.

- 0000 Not Synchronized
- 0001 Synchronized Center
- 0010 Synchronized Port
- 0011 Synchronized Starboard
- 0100 Synchronized Master
- 0101-1110 Reserved
- 1111 Take no action

Bit Length: 4 bits
 Type: Status
 Suspect Parameter Number: 2615
 Parameter Group Number: [64988]

spn2616 - Trolling Mode Status - The status of the Trolling Mode. Trolling mode limits the top speed. Full range travel of the throttle level spans from low idle engine speed to maximum trolling speed.

- 00 Trolling mode is OFF.
- 01 Trolling mode is ACTIVE.
- 10 Reserved
- 11 Take no action

Bit Length: 2 bits
 Type: Status
 Suspect Parameter Number: 2616
 Parameter Group Number: [64988]

spn2617 - Slow Vessel Mode Status - The status of the Slow Vessel Mode. Slow Vessel Mode puts the engine in a lower-than-normal low idle speed during docking or other slow vessel operations.

- 00 Slow vessel mode is OFF.
- 01 Slow vessel mode is ACTIVE.
- 10 Reserved
- 11 Take no action

Bit Length: 2 bits

Type: Status
 Suspect Parameter Number: 2617
 Parameter Group Number: [64988]

spn2629 - Turbocharger 1 Compressor Outlet Temperature - Temperature of the air exiting the turbocharger 1 compressor outlet

Data Length: 2 bytes
 Resolution: 0.03125 deg C/bit , -273 deg C offset
 Data Range: -273 to 1735 deg C
 Type: Measured
 Suspect Parameter Number: 2629
 Parameter Group Number: [64979]

spn2659 - EGR Mass Flow Rate - Flow rate of gas through the EGR system. Flow rate of the exhaust gas being recirculated into the combustion air.

Data Length: 2 bytes
 Resolution: 0.05 kg/h per bit , 0 offset
 Data Range: 0 to 3212.75 kg/h
 Type: Measured
 Suspect Parameter Number: 2659
 Parameter Group Number: [61450]

spn2660 - Joystick 1 X-Axis Position - The position of the joystick in the relative motion of travel from the neutral position. Position value of 0 is Neutral and position value 1000 (100%) is the end of linear zone. Value of 1022 indicates an error has occurred.

Data Length: 10 bits
 Resolution: 0.1 %/bit , 0 offset
 Data Range: 0 to 102 %
 Operating Range: 0.0 to 100.0%
 Type: Measured
 Suspect Parameter Number: 2660
 Parameter Group Number: [64982]

spn2661 - Joystick 1 Y-Axis Position - The position of the joystick in the relative motion of travel from the neutral position. Position value of 0 is Neutral and position value 1000 (100%) is the end of linear zone. Value of 1022 indicates an error has occurred.

Data Length: 10 bits
 Resolution: 0.1 %/bit , 0 offset
 Data Range: 0 to 102 %
 Operating Range: 0.0 to 100.0%
 Type: Measured
 Suspect Parameter Number: 2661
 Parameter Group Number: [64982]

spn2662 - Joystick 1 Grip X-Axis Position - The position of the joystick grip in the relative motion of travel from the neutral position. Position value of 0 is Neutral and position value 1000 (100%) is the end of linear zone. Value of 1022 indicates an error has occurred.

Data Length:	10 bits
Resolution:	0.1 %/bit , 0 offset
Data Range:	0 to 102 %
Operating Range:	0.0 to 100.0%
Type:	Measured
Suspect Parameter Number:	2662
Parameter Group Number:	[64983]

spn2663 - Joystick 1 Grip Y-Axis Position - The position of the joystick grip in the relative motion of travel from the neutral position. Position value of 0 is Neutral and position value 1000 (100%) is the end of linear zone. Value of 1022 indicates an error has occurred.

Data Length:	10 bits
Resolution:	0.1 %/bit , 0 offset
Data Range:	0 to 102 %
Operating Range:	0.0 to 100.0%
Type:	Measured
Suspect Parameter Number:	2663
Parameter Group Number:	[64983]

spn2664 - Joystick 1 Theta-Axis Position - The position of the joystick in the relative motion of travel from the neutral position. Position value of 0 is Neutral and position value 1000 (100%) is the end of linear zone. Value of 1022 indicates an error has occurred.

Data Length:	10 bits
Resolution:	0.1 %/bit , 0 offset
Data Range:	0 to 102 %
Operating Range:	0.0 to 100.0%
Type:	Measured
Suspect Parameter Number:	2664
Parameter Group Number:	[64983]

spn2665 - Joystick 1 X-Axis Lever Right Positive Position Status - Reports when the current joystick position is on the positive travel side (forward, right, clockwise, up) relative to the neutral position for that axis of travel.

00 Not on Positive side of Neutral
 01 On positive side of Neutral
 10 Error Indicator
 11 Not Available

Bit Length:	2 bits
Type:	Measured
Suspect Parameter Number:	2665
Parameter Group Number:	[64982]

spn2666 - Joystick 1 Y-Axis Lever Forward Positive Position Status - Reports when the current joystick position is on the positive travel side (forward, right, clockwise, up) relative to the neutral position for that axis of travel.

00 Not on Positive side of Neutral
 01 On positive side of Neutral
 10 Error Indicator
 11 Not Available

Bit Length: 2 bits
 Type: Measured
 Suspect Parameter Number: 2666
 Parameter Group Number: [64982]

spn2667 - Joystick 1 Grip X-Axis Lever Right Positive Position Status - Reports when the current joystick grip position is on the positive travel side (forward, right, clockwise, up) relative to the neutral position for that axis of travel.

00 Not on Positive side of Neutral
 01 On positive side of Neutral
 10 Error Indicator
 11 Not Available

Bit Length: 2 bits
 Type: Measured
 Suspect Parameter Number: 2667
 Parameter Group Number: [64983]

spn2668 - Joystick 1 Grip Y-Axis Lever Forward Positive Position Status - Reports when the current joystick grip position is on the positive travel side (forward, right, clockwise, up) relative to the neutral position for that axis of travel.

00 Not on Positive side of Neutral
 01 On positive side of Neutral
 10 Error Indicator
 11 Not Available

Bit Length: 2 bits
 Type: Measured
 Suspect Parameter Number: 2668
 Parameter Group Number: [64983]

spn2669 - Joystick 1 Theta-Axis Clockwise Positive Position Status - Reports when the current joystick position is on the positive travel side (forward, right, clockwise, up) relative to the neutral position for that axis of travel.

00 Not on Positive side of Neutral
 01 On positive side of Neutral
 10 Error Indicator
 11 Not Available

Bit Length: 2 bits
 Type: Measured
 Suspect Parameter Number: 2669
 Parameter Group Number: [64983]

spn2670 - Joystick 1 X-Axis Lever Left Negative Position Status - Reports when the current joystick position is on the negative travel side (back, left, counterclockwise, down) relative to the neutral position for that axis of travel.

00 Not on negative side of Neutral
 01 On negative side of Neutral
 10 Error Indicator
 11 Not Available

Bit Length: 2 bits
 Type: Measured
 Suspect Parameter Number: 2670
 Parameter Group Number: [64982]

spn2671 - Joystick 1 Y-Axis Lever Back Negative Position Status - Reports when the current joystick position is on the negative travel side (back, left, counterclockwise, down) relative to the neutral position for that axis of travel.

- 00 Not on negative side of Neutral
- 01 On negative side of Neutral
- 10 Error Indicator
- 11 Not Available

Bit Length: 2 bits
 Type: Measured
 Suspect Parameter Number: 2671
 Parameter Group Number: [64982]

spn2672 - Joystick 1 Grip X-Axis Lever Left Negative Position Status - Reports when the current joystick grip position is on the negative travel side (back, left, counterclockwise, down) relative to the neutral position for that axis of travel.

- 00 Not on negative side of Neutral
- 01 On negative side of Neutral
- 10 Error Indicator
- 11 Not Available

Bit Length: 2 bits
 Type: Measured
 Suspect Parameter Number: 2672
 Parameter Group Number: [64983]

spn2673 - Joystick 1 Grip Y-Axis Lever Back Negative Position Status - Reports when the current joystick grip position is on the negative travel side (back, left, counterclockwise, down) relative to the neutral position for that axis of travel.

- 00 Not on negative side of Neutral
- 01 On negative side of Neutral
- 10 Error Indicator
- 11 Not Available

Bit Length: 2 bits
 Type: Measured
 Suspect Parameter Number: 2673
 Parameter Group Number: [64983]

spn2674 - Joystick 1 Theta-Axis Counter Clockwise Negative Position Status - Reports when the current joystick position is on the negative travel side (back, left, counterclockwise, down) relative to the neutral position for that axis of travel.

- 00 Not on negative side of Neutral
- 01 On negative side of Neutral
- 10 Error Indicator
- 11 Not Available

Bit Length: 2 bits
 Type: Measured
 Suspect Parameter Number: 2674
 Parameter Group Number: [64983]

spn2675 - Joystick 1 X-Axis Neutral Position Status - Reports when the current joystick position is in the neutral position for that axis of travel. The neutral position measurement must be determined from some mechanism other than the axis position measurement device.

- 00 Not in Neutral Position
- 01 In Neutral Position
- 10 Error Indicator
- 11 Not Available

Bit Length: 2 bits
 Type: Measured
 Suspect Parameter Number: 2675
 Parameter Group Number: [64982]

spn2676 - Joystick 1 Y-Axis Neutral Position Status - Reports when the current joystick position is in the neutral position for that axis of travel. The neutral position measurement must be determined from some mechanism other than the axis position measurement device.

- 00 Not in Neutral Position
- 01 In Neutral Position
- 10 Error Indicator
- 11 Not Available

Bit Length: 2 bits
 Type: Measured
 Suspect Parameter Number: 2676
 Parameter Group Number: [64982]

spn2677 - Joystick 1 Grip X-Axis Neutral Position Status - Reports when the current joystick grip position is in the neutral position for that axis of travel. The neutral position measurement must be determined from some mechanism other than the axis position measurement device.

- 00 Not in Neutral Position
- 01 In Neutral Position
- 10 Error Indicator
- 11 Not Available

Bit Length: 2 bits
 Type: Measured
 Suspect Parameter Number: 2677
 Parameter Group Number: [64983]

spn2678 - Joystick 1 Grip Y-Axis Neutral Position Status - Reports when the current joystick grip position is in the neutral position for that axis of travel. The neutral position measurement must be determined from some mechanism other than the axis position measurement device.

- 00 Not in Neutral Position
- 01 In Neutral Position
- 10 Error Indicator
- 11 Not Available

Bit Length: 2 bits
 Type: Measured
 Suspect Parameter Number: 2678
 Parameter Group Number: [64983]

spn2679 - Joystick 1 Theta-Axis Neutral Position Status - Reports when the current joystick position is in the neutral position for that axis of travel. The neutral position measurement must be determined from some mechanism other than the axis position measurement device.

- 00 Not in Neutral Position
- 01 In Neutral Position
- 10 Error Indicator
- 11 Not Available

Bit Length: 2 bits
 Type: Measured

Suspect Parameter Number: 2679
 Parameter Group Number: [64983]

spn2680 - Joystick 1 X-Axis Detent Position Status - Reports when the current joystick position is in the detent position for that axis of travel.

- 00 Not in the Detent Position
- 01 In the Detent Position
- 10 Error Indicator
- 11 Not Available

Bit Length: 2 bits
 Type: Measured
 Suspect Parameter Number: 2680
 Parameter Group Number: [64982]

spn2681 - Joystick 1 Y-Axis Detent Position Status - Reports when the current joystick position is in the detent position for that axis of travel.

- 00 Not in the Detent Position
- 01 In the Detent Position
- 10 Error Indicator
- 11 Not Available

Bit Length: 2 bits
 Type: Measured
 Suspect Parameter Number: 2681
 Parameter Group Number: [64982]

spn2682 - Joystick 1 Grip X-Axis Detent Position Status - Reports when the current joystick grip position is in the detent position for that axis of travel.

- 00 Not in the Detent Position
- 01 In the Detent Position
- 10 Error Indicator
- 11 Not Available

Bit Length: 2 bits
 Type: Measured
 Suspect Parameter Number: 2682
 Parameter Group Number: [64983]

spn2683 - Joystick 1 Grip Y-Axis Detent Position Status - Reports when the current joystick grip position is in the detent position for that axis of travel.

- 00 Not in the Detent Position
- 01 In the Detent Position
- 10 Error Indicator
- 11 Not Available

Bit Length: 2 bits
 Type: Measured
 Suspect Parameter Number: 2683
 Parameter Group Number: [64983]

spn2684 - Joystick 1 Theta-Axis Detent Position Status - Reports when the current joystick position is in the detent position for that axis of travel.

- 00 Not in the Detent Position
- 01 In the Detent Position

10 Error Indicator
11 Not Available

Bit Length: 2 bits
Type: Measured
Suspect Parameter Number: 2684
Parameter Group Number: [64983]

spn2685 - Joystick 1 Button 1 Pressed Status - Reports when the joystick button has been pressed.

00 Button not pressed
01 Button pressed
10 Error Indicator
11 Not Available

Bit Length: 2 bits
Type: Measured
Suspect Parameter Number: 2685
Parameter Group Number: [64982]

spn2686 - Joystick 1 Button 2 Pressed Status - Reports when the joystick button has been pressed.

00 Button not pressed
01 Button pressed
10 Error Indicator
11 Not Available

Bit Length: 2 bits
Type: Measured
Suspect Parameter Number: 2686
Parameter Group Number: [64982]

spn2687 - Joystick 1 Button 3 Pressed Status - Reports when the joystick button has been pressed.

00 Button not pressed
01 Button pressed
10 Error Indicator
11 Not Available

Bit Length: 2 bits
Type: Measured
Suspect Parameter Number: 2687
Parameter Group Number: [64982]

spn2688 - Joystick 1 Button 4 Pressed Status - Reports when the joystick button has been pressed.

00 Button not pressed
01 Button pressed
10 Error Indicator
11 Not Available

Bit Length: 2 bits
Type: Measured
Suspect Parameter Number: 2688
Parameter Group Number: [64982]

spn2689 - Joystick 1 Button 5 Pressed Status - Reports when the joystick button has been pressed.

00 Button not pressed
01 Button pressed
10 Error Indicator
11 Not Available

Bit Length: 2 bits
 Type: Measured
 Suspect Parameter Number: 2689
 Parameter Group Number: [64982]

spn2690 - Joystick 1 Button 6 Pressed Status - Reports when the joystick button has been pressed.

00 Button not pressed
 01 Button pressed
 10 Error Indicator
 11 Not Available

Bit Length: 2 bits
 Type: Measured
 Suspect Parameter Number: 2690
 Parameter Group Number: [64982]

spn2691 - Joystick 1 Button 7 Pressed Status - Reports when the joystick button has been pressed.

00 Button not pressed
 01 Button pressed
 10 Error Indicator
 11 Not Available

Bit Length: 2 bits
 Type: Measured
 Suspect Parameter Number: 2691
 Parameter Group Number: [64982]

spn2692 - Joystick 1 Button 8 Pressed Status - Reports when the joystick button has been pressed.

00 Button not pressed
 01 Button pressed
 10 Error Indicator
 11 Not Available

Bit Length: 2 bits
 Type: Measured
 Suspect Parameter Number: 2692
 Parameter Group Number: [64982]

spn2693 - Joystick 1 Button 9 Pressed Status - Reports when the joystick button has been pressed.

00 Button not pressed
 01 Button pressed
 10 Error Indicator
 11 Not Available

Bit Length: 2 bits
 Type: Measured
 Suspect Parameter Number: 2693
 Parameter Group Number: [64982]

spn2694 - Joystick 1 Button 10 Pressed Status - Reports when the joystick button has been pressed.

00 Button not pressed
 01 Button pressed
 10 Error Indicator
 11 Not Available

Bit Length: 2 bits

Type: Measured
 Suspect Parameter Number: 2694
 Parameter Group Number: [64982]

spn2695 - Joystick 1 Button 11 Pressed Status - Reports when the joystick button has been pressed.

00 Button not pressed
 01 Button pressed
 10 Error Indicator
 11 Not Available

Bit Length: 2 bits
 Type: Measured
 Suspect Parameter Number: 2695
 Parameter Group Number: [64982]

spn2696 - Joystick 1 Button 12 Pressed Status - Reports when the joystick button has been pressed.

00 Button not pressed
 01 Button pressed
 10 Error Indicator
 11 Not Available

Bit Length: 2 bits
 Type: Measured
 Suspect Parameter Number: 2696
 Parameter Group Number: [64982]

spn2697 - Joystick 2 X-Axis Position - The position of the joystick in the relative motion of travel from the neutral position. Position value of 0 is Neutral and position value 1000 (100%) is the end of linear zone. Value of 1022 indicates an error has occurred.

Data Length: 10 bits
 Resolution: 0.1 %/bit , 0 offset
 Data Range: 0 to 102 %
 Operating Range: 0.0 to 100.0%
 Type: Measured
 Suspect Parameter Number: 2697
 Parameter Group Number: [64984]

spn2698 - Joystick 2 Y-Axis Position - The position of the joystick in the relative motion of travel from the neutral position. Position value of 0 is Neutral and position value 1000 (100%) is the end of linear zone. Value of 1022 indicates an error has occurred.

Data Length: 10 bits
 Resolution: 0.1 %/bit , 0 offset
 Data Range: 0 to 102 %
 Operating Range: 0.0 to 100.0%
 Type: Measured
 Suspect Parameter Number: 2698
 Parameter Group Number: [64984]

spn2699 - Joystick 2 Grip X-Axis Position - The position of the joystick grip in the relative motion of travel from the

neutral position. Position value of 0 is Neutral and position value 1000 (100%) is the end of linear zone. Value of 1022 indicates an error has occurred.

Data Length: 10 bits
 Resolution: 0.1 %/bit , 0 offset
 Data Range: 0 to 102 %
 Operating Range: 0.0 to 100.0%
 Type: Measured
 Suspect Parameter Number: 2699
 Parameter Group Number: [64985]

spn2700 - Joystick 2 Grip Y-Axis Position - The position of the joystick grip in the relative motion of travel from the neutral position. Position value of 0 is Neutral and position value 1000 (100%) is the end of linear zone. Value of 1022 indicates an error has occurred.

Data Length: 10 bits
 Resolution: 0.1 %/bit , 0 offset
 Data Range: 0 to 102 %
 Operating Range: 0.0 to 100.0%
 Type: Measured
 Suspect Parameter Number: 2700
 Parameter Group Number: [64985]

spn2701 - Joystick 2 Theta-Axis Position - The position of the joystick in the relative motion of travel from the neutral position. Position value of 0 is Neutral and position value 1000 (100%) is the end of linear zone. Value of 1022 indicates an error has occurred.

Data Length: 10 bits
 Resolution: 0.1 %/bit , 0 offset
 Data Range: 0 to 102 %
 Operating Range: 0.0 to 100.0%
 Type: Measured
 Suspect Parameter Number: 2701
 Parameter Group Number: [64985]

spn2702 - Joystick 2 X-Axis Lever Right Positive Position Status - Reports when the current joystick position is on the positive travel side (forward, right, clockwise, up) relative to the neutral position for that axis of travel.

- 00 Not on Positive side of Neutral
- 01 On positive side of Neutral
- 10 Error Indicator
- 11 Not Available

Bit Length: 2 bits
 Type: Measured
 Suspect Parameter Number: 2702
 Parameter Group Number: [64984]

spn2703 - Joystick 2 Y-Axis Lever Forward Positive Position Status - Reports when the current joystick position is on the positive travel side (forward, right, clockwise, up) relative to the neutral position for that axis of travel.

- 00 Not on Positive side of Neutral
- 01 On positive side of Neutral

10 Error Indicator
11 Not Available

Bit Length: 2 bits
Type: Measured
Suspect Parameter Number: 2703
Parameter Group Number: [64984]

spn2704 - Joystick 2 Grip X-Axis Lever Right Positive Position Status - Reports when the current joystick grip position is on the positive travel side (forward, right, clockwise, up) relative to the neutral position for that axis of travel.

00 Not on Positive side of Neutral
01 On positive side of Neutral
10 Error Indicator
11 Not Available

Bit Length: 2 bits
Type: Measured
Suspect Parameter Number: 2704
Parameter Group Number: [64985]

spn2705 - Joystick 2 Grip Y-Axis Lever Forward Positive Position Status - Reports when the current joystick grip position is on the positive travel side (forward, right, clockwise, up) relative to the neutral position for that axis of travel.

00 Not on Positive side of Neutral
01 On positive side of Neutral
10 Error Indicator
11 Not Available

Bit Length: 2 bits
Type: Measured
Suspect Parameter Number: 2705
Parameter Group Number: [64985]

spn2706 - Joystick 2 Theta-Axis Clockwise Positive Position Status - Reports when the current joystick position is on the positive travel side (forward, right, clockwise, up) relative to the neutral position for that axis of travel.

00 Not on Positive side of Neutral
01 On positive side of Neutral
10 Error Indicator
11 Not Available

Bit Length: 2 bits
Type: Measured
Suspect Parameter Number: 2706
Parameter Group Number: [64985]

spn2707 - Joystick 2 X-Axis Lever Left Negative Position Status - Reports when the current joystick position is on the negative travel side (back, left, counterclockwise, down) relative to the neutral position for that axis of travel.

00 Not on negative side of Neutral
01 On negative side of Neutral
10 Error Indicator
11 Not Available

Bit Length: 2 bits
Type: Measured
Suspect Parameter Number: 2707
Parameter Group Number: [64984]

spn2708 - Joystick 2 Y-Axis Lever Back Negative Position Status - Reports when the current joystick position is on the negative travel side (back, left, counterclockwise, down) relative to the neutral position for that axis of travel.

- 00 Not on negative side of Neutral
- 01 On negative side of Neutral
- 10 Error Indicator
- 11 Not Available

Bit Length: 2 bits
 Type: Measured
 Suspect Parameter Number: 2708
 Parameter Group Number: [64984]

spn2709 - Joystick 2 Grip X-Axis Lever Left Negative Position Status - Reports when the current joystick grip position is on the negative travel side (back, left, counterclockwise, down) relative to the neutral position for that axis of travel.

- 00 Not on negative side of Neutral
- 01 On negative side of Neutral
- 10 Error Indicator
- 11 Not Available

Bit Length: 2 bits
 Type: Measured
 Suspect Parameter Number: 2709
 Parameter Group Number: [64985]

spn2710 - Joystick 2 Grip Y-Axis Lever Back Negative Position Status - Reports when the current joystick grip position is on the negative travel side (back, left, counterclockwise, down) relative to the neutral position for that axis of travel.

- 00 Not on negative side of Neutral
- 01 On negative side of Neutral
- 10 Error Indicator
- 11 Not Available

Bit Length: 2 bits
 Type: Measured
 Suspect Parameter Number: 2710
 Parameter Group Number: [64985]

spn2711 - Joystick 2 Theta-Axis Counter Clockwise Negative Position Status - Reports when the current joystick position is on the negative travel side (back, left, counterclockwise, down) relative to the neutral position for that axis of travel.

- 00 Not on negative side of Neutral
- 01 On negative side of Neutral
- 10 Error Indicator
- 11 Not Available

Bit Length: 2 bits
 Type: Measured
 Suspect Parameter Number: 2711
 Parameter Group Number: [64985]

spn2712 - Joystick 2 X-Axis Neutral Position Status - Reports when the current joystick position is in the neutral position for that axis of travel. The neutral position measurement must be determined from some mechanism other than the axis position measurement device.

- 00 Not in Neutral Position
- 01 In Neutral Position
- 10 Error Indicator
- 11 Not Available

Bit Length: 2 bits
 Type: Measured
 Suspect Parameter Number: 2712
 Parameter Group Number: [64984]

spn2713 - Joystick 2 Y-Axis Neutral Position Status - Reports when the current joystick position is in the neutral position for that axis of travel. The neutral position measurement must be determined from some mechanism other than the axis position measurement device.

- 00 Not in Neutral Position
- 01 In Neutral Position
- 10 Error Indicator
- 11 Not Available

Bit Length: 2 bits
 Type: Measured
 Suspect Parameter Number: 2713
 Parameter Group Number: [64984]

spn2714 - Joystick 2 Grip X-Axis Neutral Position Status - Reports when the current joystick grip position is in the neutral position for that axis of travel. The neutral position measurement must be determined from some mechanism other than the axis position measurement device.

- 00 Not on negative side of Neutral
- 01 On negative side of Neutral
- 10 Error Indicator
- 11 Not Available

Bit Length: 2 bits
 Type: Measured
 Suspect Parameter Number: 2714
 Parameter Group Number: [64985]

spn2715 - Joystick 2 Grip Y-Axis Neutral Position Status - Reports when the current joystick grip position is in the neutral position for that axis of travel. The neutral position measurement must be determined from some mechanism other than the axis position measurement device.

- 00 Not in Neutral Position
- 01 In Neutral Position
- 10 Error Indicator
- 11 Not Available

Bit Length: 2 bits
 Type: Measured
 Suspect Parameter Number: 2715
 Parameter Group Number: [64985]

spn2716 - Joystick 2 Theta-Axis Neutral Position Status - Reports when the current joystick position is in the neutral position for that axis of travel. The neutral position measurement must be determined from some mechanism other than the axis position measurement device.

- 00 Not in Neutral Position
- 01 In Neutral Position
- 10 Error Indicator
- 11 Not Available

Bit Length: 2 bits
 Type: Measured

Suspect Parameter Number: 2716
 Parameter Group Number: [64985]

spn2717 - Joystick 2 X-Axis Detent Position Status - Reports when the current joystick position is in the detent position for that axis of travel.

- 00 Not in the Detent Position
- 01 In the Detent Position
- 10 Error Indicator
- 11 Not Available

Bit Length: 2 bits
 Type: Measured
 Suspect Parameter Number: 2717
 Parameter Group Number: [64984]

spn2718 - Joystick 2 Y-Axis Detent Position Status - Reports when the current joystick position is in the detent position for that axis of travel.

- 00 Not in the Detent Position
- 01 In the Detent Position
- 10 Error Indicator
- 11 Not Available

Bit Length: 2 bits
 Type: Measured
 Suspect Parameter Number: 2718
 Parameter Group Number: [64984]

spn2719 - Joystick 2 Grip X-Axis Detent Position Status - Reports when the current joystick grip position is in the detent position for that axis of travel.

- 00 Not in the Detent Position
- 01 In the Detent Position
- 10 Error Indicator
- 11 Not Available

Bit Length: 2 bits
 Type: Measured
 Suspect Parameter Number: 2719
 Parameter Group Number: [64985]

spn2720 - Joystick 2 Grip Y-Axis Detent Position Status - Reports when the current joystick grip position is in the detent position for that axis of travel.

- 00 Not in the Detent Position
- 01 In the Detent Position
- 10 Error Indicator
- 11 Not Available

Bit Length: 2 bits
 Type: Measured
 Suspect Parameter Number: 2720
 Parameter Group Number: [64985]

spn2721 - Joystick 2 Theta-Axis Detent Position Status - Reports when the current joystick position is in the detent position for that axis of travel.

- 00 Not in the Detent Position
- 01 In the Detent Position

10 Error Indicator
11 Not Available

Bit Length: 2 bits
Type: Measured
Suspect Parameter Number: 2721
Parameter Group Number: [64985]

spn2722 - Joystick 2 Button 1 Pressed Status - Reports when the joystick button has been pressed.

00 Button not pressed
01 Button pressed
10 Error Indicator
11 Not Available

Bit Length: 2 bits
Type: Measured
Suspect Parameter Number: 2722
Parameter Group Number: [64984]

spn2723 - Joystick 2 Button 2 Pressed Status - Reports when the joystick button has been pressed.

00 Button not pressed
01 Button pressed
10 Error Indicator
11 Not Available

Bit Length: 2 bits
Type: Measured
Suspect Parameter Number: 2723
Parameter Group Number: [64984]

spn2724 - Joystick 2 Button 3 Pressed Status - Reports when the joystick button has been pressed.

00 Button not pressed
01 Button pressed
10 Error Indicator
11 Not Available

Bit Length: 2 bits
Type: Measured
Suspect Parameter Number: 2724
Parameter Group Number: [64984]

spn2725 - Joystick 2 Button 4 Pressed Status - Reports when the joystick button has been pressed.

00 Button not pressed
01 Button pressed
10 Error Indicator
11 Not Available

Bit Length: 2 bits
Type: Measured
Suspect Parameter Number: 2725
Parameter Group Number: [64984]

spn2726 - Joystick 2 Button 5 Pressed Status - Reports when the joystick button has been pressed.

00 Button not pressed
01 Button pressed
10 Error Indicator
11 Not Available

Bit Length: 2 bits
 Type: Measured
 Suspect Parameter Number: 2726
 Parameter Group Number: [64984]

spn2727 - Joystick 2 Button 6 Pressed Status - Reports when the joystick button has been pressed.

00 Button not pressed
 01 Button pressed
 10 Error Indicator
 11 Not Available

Bit Length: 2 bits
 Type: Measured
 Suspect Parameter Number: 2727
 Parameter Group Number: [64984]

spn2728 - Joystick 2 Button 7 Pressed Status - Reports when the joystick button has been pressed.

00 Button not pressed
 01 Button pressed
 10 Error Indicator
 11 Not Available

Bit Length: 2 bits
 Type: Measured
 Suspect Parameter Number: 2728
 Parameter Group Number: [64984]

spn2729 - Joystick 2 Button 8 Pressed Status - Reports when the joystick button has been pressed.

00 Button not pressed
 01 Button pressed
 10 Error Indicator
 11 Not Available

Bit Length: 2 bits
 Type: Measured
 Suspect Parameter Number: 2729
 Parameter Group Number: [64984]

spn2730 - Joystick 2 Button 9 Pressed Status - Reports when the joystick button has been pressed.

00 Button not pressed
 01 Button pressed
 10 Error Indicator
 11 Not Available

Bit Length: 2 bits
 Type: Measured
 Suspect Parameter Number: 2730
 Parameter Group Number: [64984]

spn2731 - Joystick 2 Button 10 Pressed Status - Reports when the joystick button has been pressed.

00 Button not pressed
 01 Button pressed
 10 Error Indicator
 11 Not Available

Bit Length: 2 bits

Type: Measured
 Suspect Parameter Number: 2731
 Parameter Group Number: [64984]

spn2732 - Joystick 2 Button 11 Pressed Status - Reports when the joystick button has been pressed.

00 Button not pressed
 01 Button pressed
 10 Error Indicator
 11 Not Available

Bit Length: 2 bits
 Type: Measured
 Suspect Parameter Number: 2732
 Parameter Group Number: [64984]

spn2733 - Joystick 2 Button 12 Pressed Status - Reports when the joystick button has been pressed.

00 Button not pressed
 01 Button pressed
 10 Error Indicator
 11 Not Available

Bit Length: 2 bits
 Type: Measured
 Suspect Parameter Number: 2733
 Parameter Group Number: [64984]

spn2734 - Joystick 3 X-Axis Position - The position of the joystick in the relative motion of travel from the neutral position. Position value of 0 is Neutral and position value 1000 (100%) is the end of linear zone. Value of 1022 indicates an error has occurred.

Data Length: 10 bits
 Resolution: 0.1 %/bit , 0 offset
 Data Range: 0 to 102 %
 Operating Range: 0.0 to 100.0%
 Type: Measured
 Suspect Parameter Number: 2734
 Parameter Group Number: [64986]

spn2735 - Joystick 3 Y-Axis Position - The position of the joystick in the relative motion of travel from the neutral position. Position value of 0 is Neutral and position value 1000 (100%) is the end of linear zone. Value of 1022 indicates an error has occurred.

Data Length: 10 bits
 Resolution: 0.1 %/bit , 0 offset
 Data Range: 0 to 102 %
 Operating Range: 0.0 to 100.0%
 Type: Measured
 Suspect Parameter Number: 2735
 Parameter Group Number: [64986]

spn2736 - Joystick 3 Grip X-Axis Position - The position of the joystick grip in the relative motion of travel from the

neutral position. Position value of 0 is Neutral and position value 1000 (100%) is the end of linear zone. Value of 1022 indicates an error has occurred.

Data Length: 10 bits
 Resolution: 0.1 %/bit , 0 offset
 Data Range: 0 to 102 %
 Operating Range: 0.0 to 100.0%
 Type: Measured
 Suspect Parameter Number: 2736
 Parameter Group Number: [64987]

spn2737 - Joystick 3 Grip Y-Axis Position - The position of the joystick grip in the relative motion of travel from the neutral position. Position value of 0 is Neutral and position value 1000 (100%) is the end of linear zone. Value of 1022 indicates an error has occurred.

Data Length: 10 bits
 Resolution: 0.1 %/bit , 0 offset
 Data Range: 0 to 102 %
 Operating Range: 0.0 to 100.0%
 Type: Measured
 Suspect Parameter Number: 2737
 Parameter Group Number: [64987]

spn2738 - Joystick 3 Theta-Axis Position - The position of the joystick in the relative motion of travel from the neutral position. Position value of 0 is Neutral and position value 1000 (100%) is the end of linear zone. Value of 1022 indicates an error has occurred.

Data Length: 10 bits
 Resolution: 0.1 %/bit , 0 offset
 Data Range: 0 to 102 %
 Operating Range: 0.0 to 100.0%
 Type: Measured
 Suspect Parameter Number: 2738
 Parameter Group Number: [64987]

spn2739 - Joystick 3 X-Axis Lever Right Positive Position Status - Reports when the current joystick position is on the positive travel side (forward, right, clockwise, up) relative to the neutral position for that axis of travel.

- 00 Not on Positive side of Neutral
- 01 On positive side of Neutral
- 10 Error Indicator
- 11 Not Available

Bit Length: 2 bits
 Type: Measured
 Suspect Parameter Number: 2739
 Parameter Group Number: [64986]

spn2740 - Joystick 3 Y-Axis Lever Forward Positive Position Status - Reports when the current joystick position is on the positive travel side (forward, right, clockwise, up) relative to the neutral position for that axis of travel.

- 00 Not on Positive side of Neutral
- 01 On positive side of Neutral

10 Error Indicator
11 Not Available

Bit Length: 2 bits
Type: Measured
Suspect Parameter Number: 2740
Parameter Group Number: [64986]

spn2741 - Joystick 3 Grip X-Axis Lever Right Positive Position Status - Reports when the current joystick grip position is on the positive travel side (forward, right, clockwise, up) relative to the neutral position for that axis of travel.

00 Not on Positive side of Neutral
01 On positive side of Neutral
10 Error Indicator
11 Not Available

Bit Length: 2 bits
Type: Measured
Suspect Parameter Number: 2741
Parameter Group Number: [64987]

spn2742 - Joystick 3 Grip Y-Axis Lever Forward Positive Position Status - Reports when the current joystick grip position is on the positive travel side (forward, right, clockwise, up) relative to the neutral position for that axis of travel.

00 Not on Positive side of Neutral
01 On positive side of Neutral
10 Error Indicator
11 Not Available

Bit Length: 2 bits
Type: Measured
Suspect Parameter Number: 2742
Parameter Group Number: [64987]

spn2743 - Joystick 3 Theta-Axis Clockwise Positive Position Status - Reports when the current joystick position is on the positive travel side (forward, right, clockwise, up) relative to the neutral position for that axis of travel.

00 Not on Positive side of Neutral
01 On positive side of Neutral
10 Error Indicator
11 Not Available

Bit Length: 2 bits
Type: Measured
Suspect Parameter Number: 2743
Parameter Group Number: [64987]

spn2744 - Joystick 3 X-Axis Lever Left Negative Position Status - Reports when the current joystick position is on the negative travel side (back, left, counterclockwise, down) relative to the neutral position for that axis of travel.

00 Not on negative side of Neutral
01 On negative side of Neutral
10 Error Indicator
11 Not Available

Bit Length: 2 bits
Type: Measured
Suspect Parameter Number: 2744
Parameter Group Number: [64986]

spn2745 - Joystick 3 Y-Axis Lever Back Negative Position Status - Reports when the current joystick position is on the negative travel side (back, left, counterclockwise, down) relative to the neutral position for that axis of travel.

- 00 Not on negative side of Neutral
- 01 On negative side of Neutral
- 10 Error Indicator
- 11 Not Available

Bit Length: 2 bits
 Type: Measured
 Suspect Parameter Number: 2745
 Parameter Group Number: [64986]

spn2746 - Joystick 3 Grip X-Axis Lever Left Negative Position Status - Reports when the current joystick grip position is on the negative travel side (back, left, counterclockwise, down) relative to the neutral position for that axis of travel.

- 00 Not on negative side of Neutral
- 01 On negative side of Neutral
- 10 Error Indicator
- 11 Not Available

Bit Length: 2 bits
 Type: Measured
 Suspect Parameter Number: 2746
 Parameter Group Number: [64987]

spn2747 - Joystick 3 Grip Y-Axis Lever Back Negative Position Status - Reports when the current joystick grip position is on the negative travel side (back, left, counterclockwise, down) relative to the neutral position for that axis of travel.

- 00 Not on negative side of Neutral
- 01 On negative side of Neutral
- 10 Error Indicator
- 11 Not Available

Bit Length: 2 bits
 Type: Measured
 Suspect Parameter Number: 2747
 Parameter Group Number: [64987]

spn2748 - Joystick 3 Theta-Axis Counter Clockwise Negative Position Status - Reports when the current joystick position is on the negative travel side (back, left, counterclockwise, down) relative to the neutral position for that axis of travel.

- 00 Not on negative side of Neutral
- 01 On negative side of Neutral
- 10 Error Indicator
- 11 Not Available

Bit Length: 2 bits
 Type: Measured
 Suspect Parameter Number: 2748
 Parameter Group Number: [64987]

spn2749 - Joystick 3 X-Axis Neutral Position Status - Reports when the current joystick position is in the neutral position for that axis of travel. The neutral position measurement must be determined from some mechanism other than the axis position measurement device.

- 00 Not in Neutral Position
- 01 In Neutral Position
- 10 Error Indicator
- 11 Not Available

Bit Length: 2 bits
 Type: Measured
 Suspect Parameter Number: 2749
 Parameter Group Number: [64986]

spn2750 - Joystick 3 Y-Axis Neutral Position Status - Reports when the current joystick position is in the neutral position for that axis of travel. The neutral position measurement must be determined from some mechanism other than the axis position measurement device.

- 00 Not in Neutral Position
- 01 In Neutral Position
- 10 Error Indicator
- 11 Not Available

Bit Length: 2 bits
 Type: Measured
 Suspect Parameter Number: 2750
 Parameter Group Number: [64986]

spn2751 - Joystick 3 Grip X-Axis Neutral Position Status - Reports when the current joystick grip position is in the neutral position for that axis of travel. The neutral position measurement must be determined from some mechanism other than the axis position measurement device.

- 00 Not on negative side of Neutral
- 01 On negative side of Neutral
- 10 Error Indicator
- 11 Not Available

Bit Length: 2 bits
 Type: Measured
 Suspect Parameter Number: 2751
 Parameter Group Number: [64987]

spn2752 - Joystick 3 Grip Y-Axis Neutral Position Status - Reports when the current joystick grip position is in the neutral position for that axis of travel. The neutral position measurement must be determined from some mechanism other than the axis position measurement device.

- 00 Not in Neutral Position
- 01 In Neutral Position
- 10 Error Indicator
- 11 Not Available

Bit Length: 2 bits
 Type: Measured
 Suspect Parameter Number: 2752
 Parameter Group Number: [64987]

spn2753 - Joystick 3 Theta-Axis Neutral Position Status - Reports when the current joystick position is in the neutral position for that axis of travel. The neutral position measurement must be determined from some mechanism other than the axis position measurement device.

- 00 Not in Neutral Position
- 01 In Neutral Position
- 10 Error Indicator
- 11 Not Available

Bit Length: 2 bits
 Type: Measured

Suspect Parameter Number: 2753
 Parameter Group Number: [64987]

spn2754 - Joystick 3 X-Axis Detent Position Status - Reports when the current joystick position is in the detent position for that axis of travel.

- 00 Not in the Detent Position
- 01 In the Detent Position
- 10 Error Indicator
- 11 Not Available

Bit Length: 2 bits
 Type: Measured
 Suspect Parameter Number: 2754
 Parameter Group Number: [64986]

spn2755 - Joystick 3 Y-Axis Detent Position Status - Reports when the current joystick position is in the detent position for that axis of travel.

- 00 Not in the Detent Position
- 01 In the Detent Position
- 10 Error Indicator
- 11 Not Available

Bit Length: 2 bits
 Type: Measured
 Suspect Parameter Number: 2755
 Parameter Group Number: [64986]

spn2756 - Joystick 3 Grip X-Axis Detent Position Status - Reports when the current joystick grip position is in the detent position for that axis of travel.

- 00 Not in the Detent Position
- 01 In the Detent Position
- 10 Error Indicator
- 11 Not Available

Bit Length: 2 bits
 Type: Measured
 Suspect Parameter Number: 2756
 Parameter Group Number: [64987]

spn2757 - Joystick 3 Grip Y-Axis Detent Position Status - Reports when the current joystick grip position is in the detent position for that axis of travel.

- 00 Not in the Detent Position
- 01 In the Detent Position
- 10 Error Indicator
- 11 Not Available

Bit Length: 2 bits
 Type: Measured
 Suspect Parameter Number: 2757
 Parameter Group Number: [64987]

spn2758 - Joystick 3 Theta-Axis Detent Position Status - Reports when the current joystick position is in the detent position for that axis of travel.

- 00 Not in the Detent Position
- 01 In the Detent Position

10 Error Indicator
11 Not Available

Bit Length: 2 bits
Type: Measured
Suspect Parameter Number: 2758
Parameter Group Number: [64987]

spn2759 - Joystick 3 Button 1 Pressed Status - Reports when the joystick button has been pressed.

00 Button not pressed
01 Button pressed
10 Error Indicator
11 Not Available

Bit Length: 2 bits
Type: Measured
Suspect Parameter Number: 2759
Parameter Group Number: [64986]

spn2760 - Joystick 3 Button 2 Pressed Status - Reports when the joystick button has been pressed.

00 Button not pressed
01 Button pressed
10 Error Indicator
11 Not Available

Bit Length: 2 bits
Type: Measured
Suspect Parameter Number: 2760
Parameter Group Number: [64986]

spn2761 - Joystick 3 Button 3 Pressed Status - Reports when the joystick button has been pressed.

00 Button not pressed
01 Button pressed
10 Error Indicator
11 Not Available

Bit Length: 2 bits
Type: Measured
Suspect Parameter Number: 2761
Parameter Group Number: [64986]

spn2762 - Joystick 3 Button 4 Pressed Status - Reports when the joystick button has been pressed.

00 Button not pressed
01 Button pressed
10 Error Indicator
11 Not Available

Bit Length: 2 bits
Type: Measured
Suspect Parameter Number: 2762
Parameter Group Number: [64986]

spn2763 - Joystick 3 Button 5 Pressed Status - Reports when the joystick button has been pressed.

00 Button not pressed
01 Button pressed
10 Error Indicator
11 Not Available

Bit Length: 2 bits
 Type: Measured
 Suspect Parameter Number: 2763
 Parameter Group Number: [64986]

spn2764 - Joystick 3 Button 6 Pressed Status - Reports when the joystick button has been pressed.

00 Button not pressed
 01 Button pressed
 10 Error Indicator
 11 Not Available

Bit Length: 2 bits
 Type: Measured
 Suspect Parameter Number: 2764
 Parameter Group Number: [64986]

spn2765 - Joystick 3 Button 7 Pressed Status - Reports when the joystick button has been pressed.

00 Button not pressed
 01 Button pressed
 10 Error Indicator
 11 Not Available

Bit Length: 2 bits
 Type: Measured
 Suspect Parameter Number: 2765
 Parameter Group Number: [64986]

spn2766 - Joystick 3 Button 8 Pressed Status - Reports when the joystick button has been pressed.

00 Button not pressed
 01 Button pressed
 10 Error Indicator
 11 Not Available

Bit Length: 2 bits
 Type: Measured
 Suspect Parameter Number: 2766
 Parameter Group Number: [64986]

spn2767 - Joystick 3 Button 9 Pressed Status - Reports when the joystick button has been pressed.

00 Button not pressed
 01 Button pressed
 10 Error Indicator
 11 Not Available

Bit Length: 2 bits
 Type: Measured
 Suspect Parameter Number: 2767
 Parameter Group Number: [64986]

spn2768 - Joystick 3 Button 10 Pressed Status - Reports when the joystick button has been pressed.

00 Button not pressed
 01 Button pressed
 10 Error Indicator
 11 Not Available

Bit Length: 2 bits

Type: Measured
 Suspect Parameter Number: 2768
 Parameter Group Number: [64986]

spn2769 - Joystick 3 Button 11 Pressed Status - Reports when the joystick button has been pressed.

00 Button not pressed
 01 Button pressed
 10 Error Indicator
 11 Not Available

Bit Length: 2 bits
 Type: Measured
 Suspect Parameter Number: 2769
 Parameter Group Number: [64986]

spn2770 - Joystick 3 Button 12 Pressed Status - Reports when the joystick button has been pressed.

00 Button not pressed
 01 Button pressed
 10 Error Indicator
 11 Not Available

Bit Length: 2 bits
 Type: Measured
 Suspect Parameter Number: 2770
 Parameter Group Number: [64986]

spn2789 - Calculated Turbocharger 1 Turbine Inlet Temperature - Calculated value of turbine inlet temperature based on engine operating conditions, such as intake manifold temperature, charge fuel ratio, injection timing, and engine speed. Use SPN 1180 for actual measured inlet temperature.

Data Length: 2 bytes
 Resolution: 0.03125 deg C/bit , -273 deg C offset
 Data Range: -273 to 1735 deg C
 Type: Status
 Suspect Parameter Number: 2789
 Parameter Group Number: [64981]

spn2790 - Calculated Turbocharger 1 Compressor Outlet Temperature - Calculated value of turbocharger compressor outlet air temperature. Temperature of air exiting the turbocharger compressor and before entering charge air cooler. The estimate is based on turbo speed and measured turbocharger compressor inlet temperature. Use SPN 1184 for actual measured outlet temperature.

Data Length: 2 bytes
 Resolution: 0.03125 deg C/bit , -273 deg C offset
 Data Range: -273 to 1735 deg C
 Type: Status
 Suspect Parameter Number: 2790
 Parameter Group Number: [64981]

spn2791 - Exhaust Gas Recirculation (EGR) Valve Control - Desired percentage of maximum Exhaust Gas Recirculation (EGR) valve opening. 0% means valve is closed. 100% means maximum valve opening (full gas flow).

Data Length: 2 bytes
 Resolution: 0.0025 %/bit , 0 offset
 Data Range: 0 to 160.6375 %
 Operating Range: 0 to 100%
 Type: Status
 Suspect Parameter Number: 2791
 Parameter Group Number: [64981]

spn2792 - Variable Geometry Turbocharger (VGT) Air Control Shutoff Valve - Isolates vehicle brake air from the Variable Geometry Turbocharger (VGT) system when engine is not running. This valve prevents vehicle air from bleeding off through the VGT Control Valve when engine is not in use. Primary vehicle air system from air tanks feed the VGT Air Control Shutoff Valve, which in turn provides air to the VGT Control Valve when the keyswitch is 'ON'. The VGT Control Valve delivers air to the VGT actuator to adjust turbocharger geometry.

00 VGT Air Control Shutoff Valve is Off
 01 VGT Air Control Shutoff Valve is On
 10 Reserved
 11 Not available

Bit Length: 2 bits
 Type: Status
 Suspect Parameter Number: 2792
 Parameter Group Number: [64981]

spn2793 - Laser Strike Data Latency - Time from laser strike to CAN message transmission. This parameter will be reported by survey receiver type devices only. Byte 3 (SPN 2576) of PGN 65141 identifies the type of Laser Receiver.

Data Length: 2 bytes
 Resolution: 51.2 us/bit , 0 offset
 Data Range: 0 to 3.289856 s
 Type: Measured
 Suspect Parameter Number: 2793
 Parameter Group Number: [65141]

spn2794 - Absolute Laser Strike Position - Laser Strike location on the survey type laser receiver.

Data Length: 2 bytes
 Resolution: 0.1 mm/bit , 0 offset
 Data Range: 0 to 6,425.5 mm
 Type: Measured
 Suspect Parameter Number: 2794
 Parameter Group Number: [65141]

spn2795 - VGT 1 Actuator Position - Sensor that measures the position of the variable geometry turbocharger actuator. A position of 0% indicates the actuator is in the position creating the smallest geometry turbocharger. A position of 100% represents the largest geometry turbocharger.

Data Length: 1 byte
 Resolution: 0.4 %/bit , 0 offset
 Data Range: 0 to 100 %
 Type: Measured

Suspect Parameter Number: 2795
 Parameter Group Number: [64981]

spn2796 - Transfer Case Selector Switch - Operator switch to select the condition of the transfer case. The possible states are 2 wheel drive, 4 wheel drive and neutral .

000 2 wheel
 001 4 wheel
 010 Neutral
 011 - 101 Reserved for SAE assignment
 110 Error indicator
 111 not available

Bit Length: 3 bits
 Type: Measured
 Suspect Parameter Number: 2796
 Parameter Group Number: [64980]

spn2799 - Turbocharger 2 Compressor Outlet Temperature - Temperature of the air exiting the turbocharger 2 compressor outlet

Data Length: 2 bytes
 Resolution: 0.03125 deg C/bit , -273 deg C offset
 Data Range: -273 to 1735 deg C
 Type: Measured
 Suspect Parameter Number: 2799
 Parameter Group Number: [64979]

spn2800 - Turbocharger 3 Compressor Outlet Temperature - Temperature of the air exiting the turbocharger 3 compressor outlet

Data Length: 2 bytes
 Resolution: 0.03125 deg C/bit , -273 deg C offset
 Data Range: -273 to 1735 deg C
 Type: Measured
 Suspect Parameter Number: 2800
 Parameter Group Number: [64979]

spn2801 - Turbocharger 4 Compressor Outlet Temperature - Temperature of the air exiting the turbocharger 4 compressor outlet

Data Length: 2 bytes
 Resolution: 0.03125 deg C/bit , -273 deg C offset
 Data Range: -273 to 1735 deg C
 Type: Measured
 Suspect Parameter Number: 2801
 Parameter Group Number: [64979]

spn2802 - Data Memory Usage - The used storage capacity of the data buffer memory internal to an ECU, such as a data logger.

Data Length: 1 byte

Resolution: 0.4 %/bit , 0 offset
 Data Range: 0 to 100 %
 Type: Measured
 Suspect Parameter Number: 2802
 Parameter Group Number: [64978]

spn2803 - Keep-Alive Battery Consumption - The capacity consumed from the direct battery connection since the key was last turned off. This value is maintained and does not accumulate while the key switch is on. The value is reset to 0 when the key switch is turned to the off position.

Data Length: 2 bytes
 Resolution: 1 mAhr/bit , 0 mAhr offset
 Data Range: 0 to 64255mAhr (64.255Ahr)
 Type: Measured
 Suspect Parameter Number: 2803
 Parameter Group Number: [64978]

spn2804 - FMS-standard Diagnostics Supported - Status signal which indicates if the FMS Vehicle Interface (FMS Gateway) supports the handling of diagnostic messages from the vehicle network onto the FMS network.

The FMS gateway does NOT support the re-broadcast of diagnostics messages present on the vehicle network. If this 'FMS-standard Diagnostics Supported' feature is supported by the FMS Gateway, the FMS Gateway will support the requests for diagnostics information (from the FMS device) onto the vehicle network and pass the responses onto the FMS network.

Note: This feature of the FMS Gateway is independent of the 'FMS-standard Requests Supported'. The FMS Gateway may support diagnostics without supporting the 'FMS-standard Requests Supported' function, or visa-versa.

00 Diagnostics Is Not Supported
 01 Diagnostics Is Supported
 10 Reserved
 11 Don't care

Bit Length: 2 bits
 Type: Status
 Suspect Parameter Number: 2804
 Parameter Group Number: [64977]

spn2805 - FMS-standard Requests Supported - Status signal which indicates if the FMS Vehicle Interface (FMS Gateway) will respond to requests from the FMS device for the PGNs listed in the FMS Interface Specification.

This mode is to support FMS gateway devices that only operate in a 'Request' mode.

The FMS PGNs may also be broadcast periodically in this mode.

The FMS Gateway will NOT support the requests for information not included in the FMS Interface Specification onto the vehicle network."

00 On request mode is not supported
 01 On request mode is supported
 10 Reserved
 11 Don't care

Bit Length: 2 bits
 Type: Status
 Suspect Parameter Number: 2805
 Parameter Group Number: [64977]

spn2806 - FMS-standard SW-version supported. - Information that identifies which issue level of the FMS-standard document the software included in the FMS gateway supports. Four bytes, representing xx.yy type revision level identification.

Information to be ASCII equivalent of the numeric revision level of the FMS document, 00.01 to 99.99. The first released version will

be 01.00. Note: the first 2 bytes contain the high order number of the spec, the second 2 bytes contain the lower order number of the spec. For example, FMS-standard version 02.06 would have 0 in the first byte, 2 in the second byte, 0 in the third byte and 6 in the fourth byte.

Data Length: 4 bytes
 Resolution: ASCII , 0 offset
 Data Range: 0 to 255 per byte
 Type: Measured
 Suspect Parameter Number: 2806
 Parameter Group Number: [64977]

5.3. Parameter Group Definitions - This section defines the parameter groups for use on the SAE J1939 network. All undefined bits are to be transmitted with a value of "1." All undefined bits should be received as "don't care" (either masked out or ignored). This permits them to be defined and used in the future without causing any incompatibilities. Messages that are requesting control over the receiving device (TSC1, TC1) are transmitted at high rate only during the time when the control is active, but may be optionally sent at a slow rate as a "heartbeat." For TSC1, it is expected that the transmitting device indicate to the receiving device that it no longer requests control by sending at least one broadcast with the override control modes set to 00. In the absence of continued broadcasts from a requesting module, the receiving device shall default to its normal mode after two update periods. The size of the CAN data field is 8 bytes. Parameter groups that are 0-8 data bytes in length use the services of the Data Link layer (Refer to SAE J1939-21). Parameter groups that exceed 8 data bytes or parameter group definitions that are variable in length and may exceed 8 data bytes shall utilize the services of the Transport Protocol. (Refer to 5.10 of SAE J1939-21.)

pgn0 - Torque/Speed Control 1 - TSC1 -

Transmission Repetition Rate: when active; 10 ms to engine - 50 ms to retarder
 Data Length: 8 bytes
 Data Page: 0
 PDU Format: 0
 PDU Specific: DA
 Default Priority: 3
 Parameter Group Number: 0 (000000₁₆)

Bit Start Position /Bytes	Length	SPN Description	SPN
1.1	2 bits	Override Control Mode	695
1.3	2 bits	Requested Speed Control Conditions	696
1.5	2 bits	Override Control Mode Priority	897
2-3	2 bytes	Requested Speed/Speed Limit	898
4	1 byte	Requested Torque/Torque Limit	518

NOTE - Retarder may be disabled by commanding a torque limit of 0%. Use of the limit mode allows the use of the retarder only up to the limit specified in the request. This can be used to permit retarding of up to 50%, for example, if that limit is required by some device such as an EBS, or it can disable the use of the retarder by others, as when an ABS controller detects wheel slip.

pgn256 - Transmission Control 1 - TC1 -

Transmission Repetition Rate: when active; 50 ms to transmission and axles
 Data Length: 8 bytes
 Data Page: 0
 PDU Format: 1
 PDU Specific: DA

Default Priority:		3	
Parameter Group Number:		256 (000100 ₁₆)	
Bit Start Position /Bytes	Length	SPN Description	SPN
1.1	2 bits	Gear Shift Inhibit Request	681
1.3	2 bits	Torque Converter Lockup Disable Request	682
1.5	2 bits	Disengage Driveline Request	683
2	1 byte	Requested Percent Clutch Slip	684
3	1 byte	Requested Gear	525
4.1	2 bits	Disengage Differential Lock Request - Front Axle 1	685
4.3	2 bits	Disengage Differential Lock Request - Front Axle 2	686
4.5	2 bits	Disengage Differential Lock Request - Rear Axle 1	687
4.7	2 bits	Disengage Differential Lock Request - Rear Axle 2	688
5.1	2 bits	Disengage Differential Lock Request - Central	689
5.3	2 bits	Disengage Differential Lock Request - Central Front	690
5.5	2 bits	Disengage Differential Lock Request - Central Rear	691
6.1	2 bits	Transmission Mode 1	1852
6.3	2 bits	Transmission Mode 2	1853
6.5	2 bits	Transmission Mode 3	1854
6.7	2 bits	Transmission Mode 4	1855

pgn52992 - Continuous Torque & Speed Limit Request - CTL -

Transmission Repetition Rate:		5 s	
Data Length:		8 bytes	
Data Page:		0	
PDU Format:		207	
PDU Specific:		DA	
Default Priority:		6	
Parameter Group Number:		52992 (00CF00 ₁₆)	
Bit Start Position /Bytes	Length	SPN Description	SPN
1	1 byte	Minimum Continuous Engine Speed Limit Request	1784
2	1 byte	Maximum Continuous Engine Speed Limit Request	1785
3	1 byte	Minimum Continuous Engine Torque Limit Request	1786
4	1 byte	Maximum Continuous Engine Torque Limit Request	1787
5	1 byte	Minimum Continuous Retarder Speed Limit Request	1788
6	1 byte	Maximum Continuous Retarder Speed Limit Request	1789
7	1 byte	Minimum Continuous Retarder Torque Limit Request	1790
8	1 byte	Maximum Continuous Retarder Torque Limit Request	1791

The TSC1 message allows J1939 network devices to temporarily control engine and retarder speed and torque. This approach allows engine (and retarder) speed to be controlled by one device for a limited period of time. This may need to happen for brief emergency conditions (as requested by an anti-lock braking system for example) or in order to synchronize engine speed with some other device such as a transmission in order to allow a shift. Conflicting speed and torque requests from different devices are resolved by a predefined arbitration scheme.

Not every torque or speed need is satisfactorily addressed by this plan, however. Occasionally a network device may wish to impose longer lasting limits on speed and torque. For instance, as long as a transmission is in third gear, it may not be able to withstand all the torque the engine (or retarder) can produce. Or, an auxiliary device such as a pump may only operate correctly if engine speed and torque are kept within some fairly limited range *but not necessarily at one precise speed/torque!* In these cases, the network device does not need to command the precise speed or torque, but does have a legitimate desire to keep it within some boundary for an extended period of time. The TSC1 message doesn't provide this ability.

How:

The ECM and retarder controller(s) first must define a "window" within the torque map. The window should be chosen carefully, and shouldn't be any larger than necessary. Any requests for continuous limits that attempt to intrude on this window will succeed only in setting limits at the very threshold of the window. For example, if the ECM declares that minimum continuous torque limits must be less than 900 lb-ft, and some device attempts to set a minimum continuous torque of 1000 lb-ft, the actual applied continuous limit will be 900 lb-ft (thus 900 lb-ft is the *minimum continuous* torque). When this limit is applied, the engine will always produce at least 900 lb-ft of torque. Similarly, if the engine declares that minimum continuous engine speed cannot be more than 1100 RPM, any attempts at setting a minimum continuous engine speed of over 1100 RPM will result in a minimum continuous engine speed of 1100 RPM. That is, the engine has declared beforehand that it will *always* be able to operate at least at 1100 RPM.

Periodically, the ECM and retarder controller(s) will transmit the dimensions of this window, as well as what actual continuous limits have been applied. This allows the engine to adjust the size and shape of the "window" to allow for derates and provides feedback to the various devices requesting continuous torque and/or speed limits.

The following figure shows an example torque curve with a "window" inside.

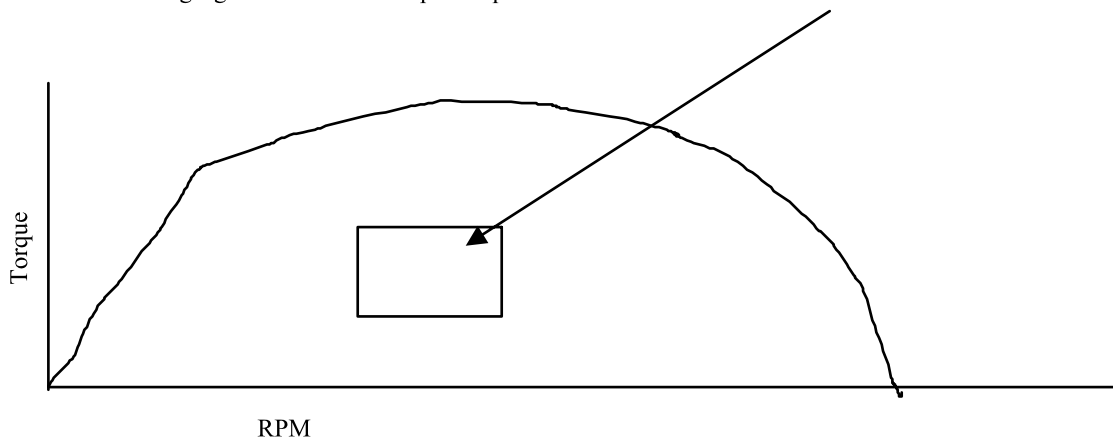

The following figure shows how the ECM will treat requests that are outside of the bounds set by the “window.” Note that the ECM has declared a “maximum allowable minimum” and a “minimum allowable maximum” for both speed and torque. These limits form a sort of rectangular “window” within the torque. The engine **must** be free to operate within this window; no continuous limits will be accepted that would intrude on it. In the diagram, some network device has ignored those values and attempted to set a minimum continuous speed higher than allowed. Remember, a minimum continuous speed means that the engine must always maintain an RPM of that value or greater. The ECM cannot accept the requested limit, so it applies a continuous limit as close as possible: right at the boundary set by “maximum value allowed for minimum continuous speed.” Requests for Minimum Continuous Speed and Max/Min continuous torque are handled the same way.

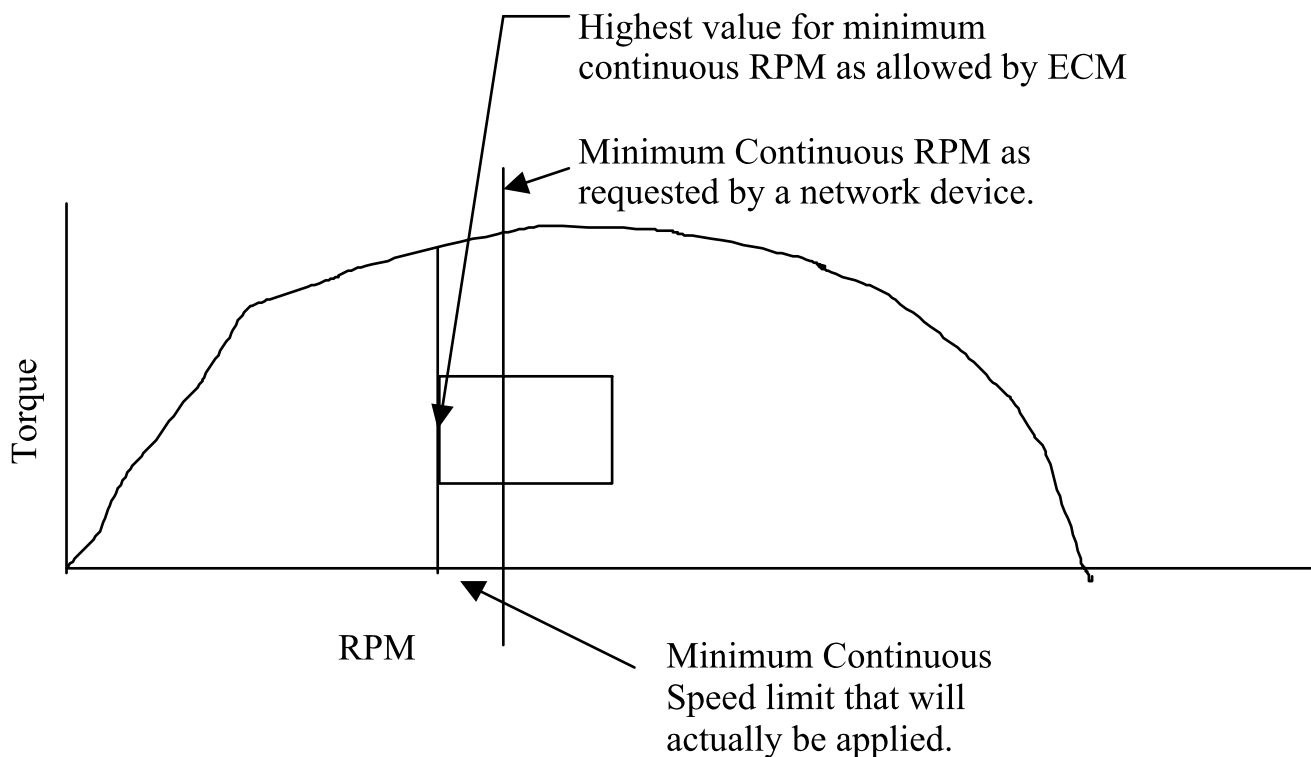

Things get a little more complicated when a retarder is included. Fortunately, only the engine compression brake retarder has any real relationship to the engine’s torque map. Because other retarders may work against the engine, only the compression brake is generally controlled by the same ECU. For this reason, we must give it more careful attention.

The following figure illustrates one of the problems. Suppose continuous limits have been applied to the engine and retarder as indicated by the rectangular boxes within the torque maps. If the engine is prohibited from allowing torque to decrease below x , how can the retarder be engaged? An engine compression brake retarder needs zero fueling for the engine in order to engage. The simple answer is that if there is a minimum continuous torque limit applied to the engine, the retarder will not be engaged. How does the reverse case behave? If the retarder is of a type other than engine compression brake, it may work against the engine and continuously produce a negative torque. Engine compression brake retarders must not send out a list of acceptable limits that would allow such conundrums. In practical terms, this means that engine compression brake retarders must set their Maximum Continuous Torque limit (think of it as MINIMUM continuous BRAKING torque limit) to zero in order for the retarder to ever be engaged. Similarly, the continuous limits as actually applied to the engine must allow zero torque if the retarder is to be engaged.

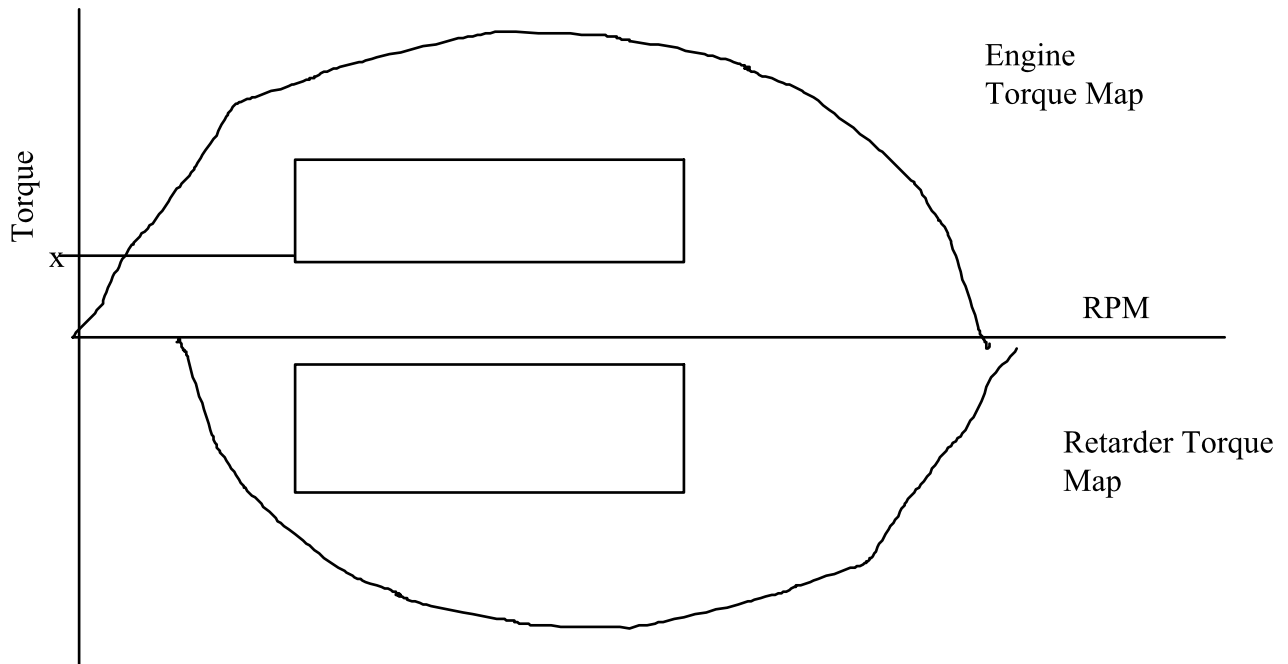

pgn53248 - Cab Illumination Message - CL -

Transmission Repetition Rate:	on change of state, but not faster than 100 ms, and every 5 s		
Data Length:	8 bytes		
Data Page:	0		
PDU Format:	208		
PDU Specific:	DA		
Default Priority:	6		
Parameter Group Number:	53248 (00D000 ₁₆)		
Bit Start Position /Bytes	Length	SPN Description	SPN
1	1 byte	Illumination Brightness Percent	1487

This message contains information that controls illumination devices inside the vehicle's cab.

pgn53504 - Air Suspension Control 6 - ASC6 -

Transmission Repetition Rate: 100 ms when active
 Data Length: 8 bytes
 Data Page: 0
 PDU Format: 209
 PDU Specific: DA
 Default Priority: 3
 Parameter Group Number: 53504 (00D100₁₆)

Bit Start Position /Bytes	Length	SPN Description	SPN
1-2	2 bytes	Level Preset Front Axle Left	1732
3-4	2 bytes	Level Preset Front Axle Right	1757
5-6	2 bytes	Level Preset Rear Axle Left	1758
7-8	2 bytes	Level Preset Rear Axle Right	1735

Used for suspension control

pgn53760 - Air Suspension Control 2 - ASC2 -

Transmission Repetition Rate: 100 ms
 Data Length: 8 bytes
 Data Page: 0
 PDU Format: 210
 PDU Specific: DA
 Default Priority: 3
 Parameter Group Number: 53760 (00D200₁₆)

Bit Start Position /Bytes	Length	SPN Description	SPN
1.3	2 bits	Kneeling Request Left Side	1749
1.5	2 bits	Kneeling Request Right Side	1748
1.7	2 bits	Kneeling Control Mode Request	1747
2.1	4 bits	Nominal Level Request Front Axle	1751
2.5	4 bits	Nominal Level Request Rear Axle	1750
3.1	4 bits	Level Control Mode Request	1753
3.5	2 bits	Lift Axle 1 Position Command	1752
3.7	2 bits	Lift Axle 2 Position Command	1828
4	1 byte	Damper Stiffness Request Front Axle	1718
5	1 byte	Damper Stiffness Request Rear Axle	1719
6	1 byte	Damper Stiffness Request Lift / Tag Axle	1720
7.1	2 bits	Kneeling Command - Front Axle	1830
7.3	2 bits	Kneeling Command - Rear Axle	1829

Used for suspension control

pgn54528 - Time/Date Adjust - TDA -

Transmission Repetition Rate: As needed
 Data Length: 8 bytes
 Data Page: 0
 PDU Format: 213

PDU Specific:		DA	
Default Priority:		6	
Parameter Group Number:		54528 (00D500 ₁₆)	
Bit Start Position /Bytes	Length	SPN Description	SPN
1	1 byte	Adjust seconds	1603
2	1 byte	Adjust minutes	1604
3	1 byte	Adjust hours	1605
4	1 byte	Adjust month	1606
5	1 byte	Adjust day	1607
6	1 byte	Adjust year	1608
7	1 byte	Adjust local minute offset	1609
8	1 byte	Adjust local hour offset	1610

pgn56320 - Anti-theft Status - ATS -

Transmission Repetition Rate: This message is transmitted in response to an Anti-Theft Request message. This message is also sent when the component abnormal power interruption. In this situation the Anti-Theft Status Report is sent without the Anti-Theft Request.

Data Length:		8 bytes	
Data Page:		0	
PDU Format:		220	
PDU Specific:		DA	
Default Priority:		7	
Parameter Group Number:		56320 (00DC00 ₁₆)	
Bit Start Position /Bytes	Length	SPN Description	SPN
1.1	2 bits	Anti-theft Encryption Seed Present Indicator	1194
1.3	2 bits	Anti-theft Password Valid Indicator	1195
1.5	2 bits	Anti-theft Component Status States	1196
1.7	2 bits	Anti-theft Modify Password States	1197
2-8	7 bytes	Anti-theft Random Number	1198

NOTE: See Figures PGN56320_A to PGN56320_F for examples of Anti-theft message transfers. Bit 1 is the right most bit in each byte.

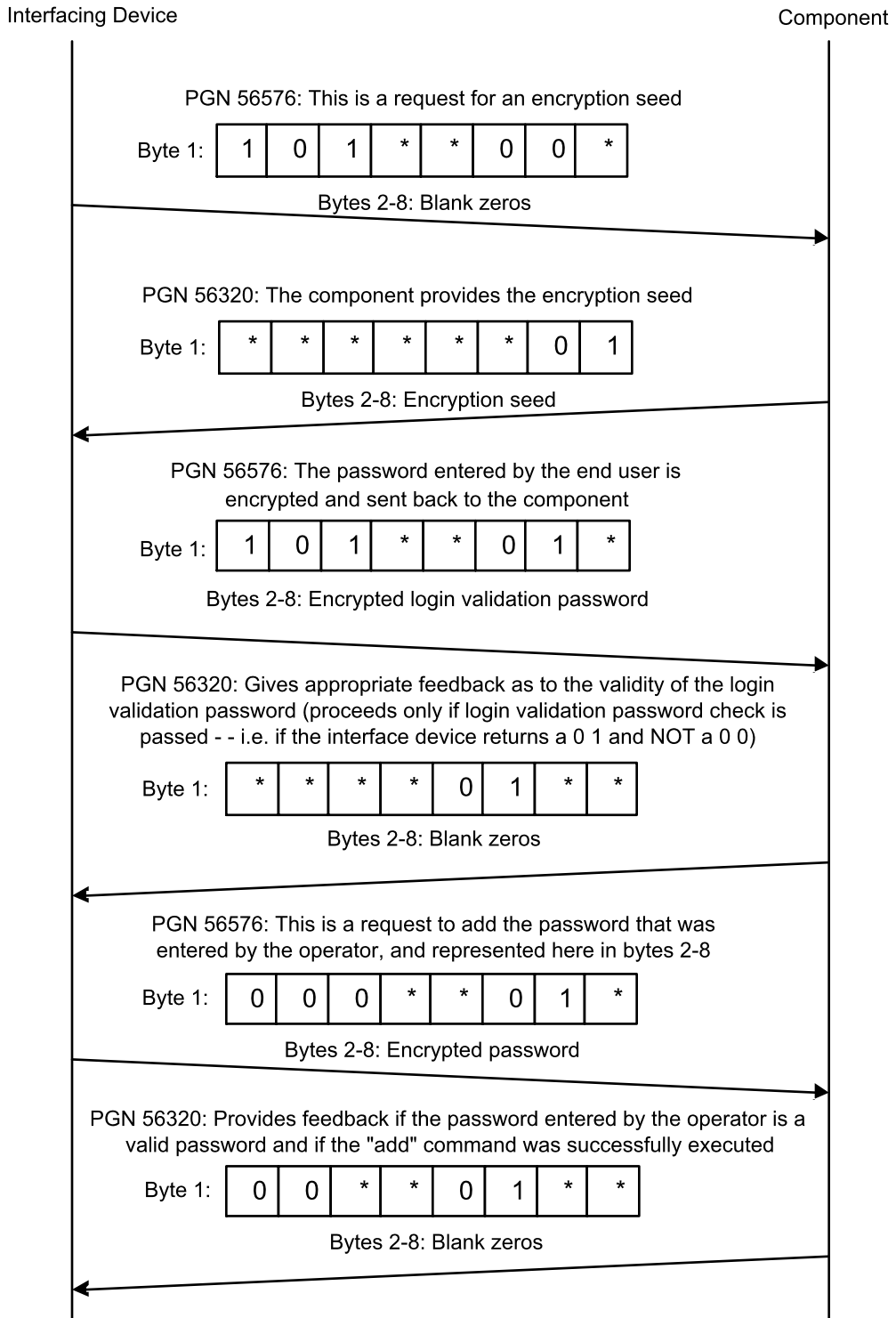

FIGURE PGN56320_A -- OPERATOR DESIRES TO ADD A PASSWORD TO THE COMPONENT'S PASSWORD STRUCTURE

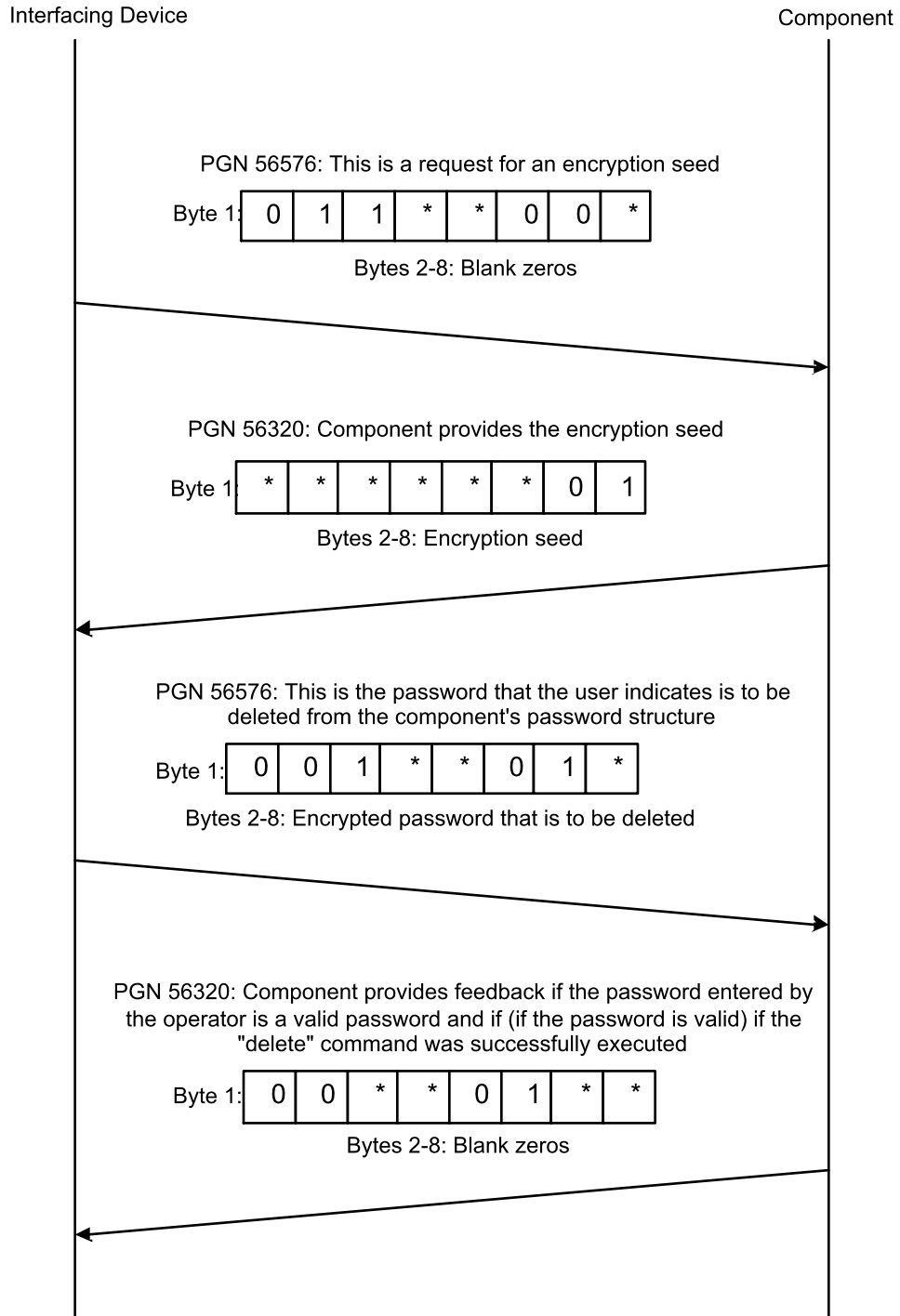

FIGURE PGN56320_B -- OPERATOR DESIRES TO DELETE A PASSWORD FROM THE COMPONENT'S PASSWORD STRUCTURE

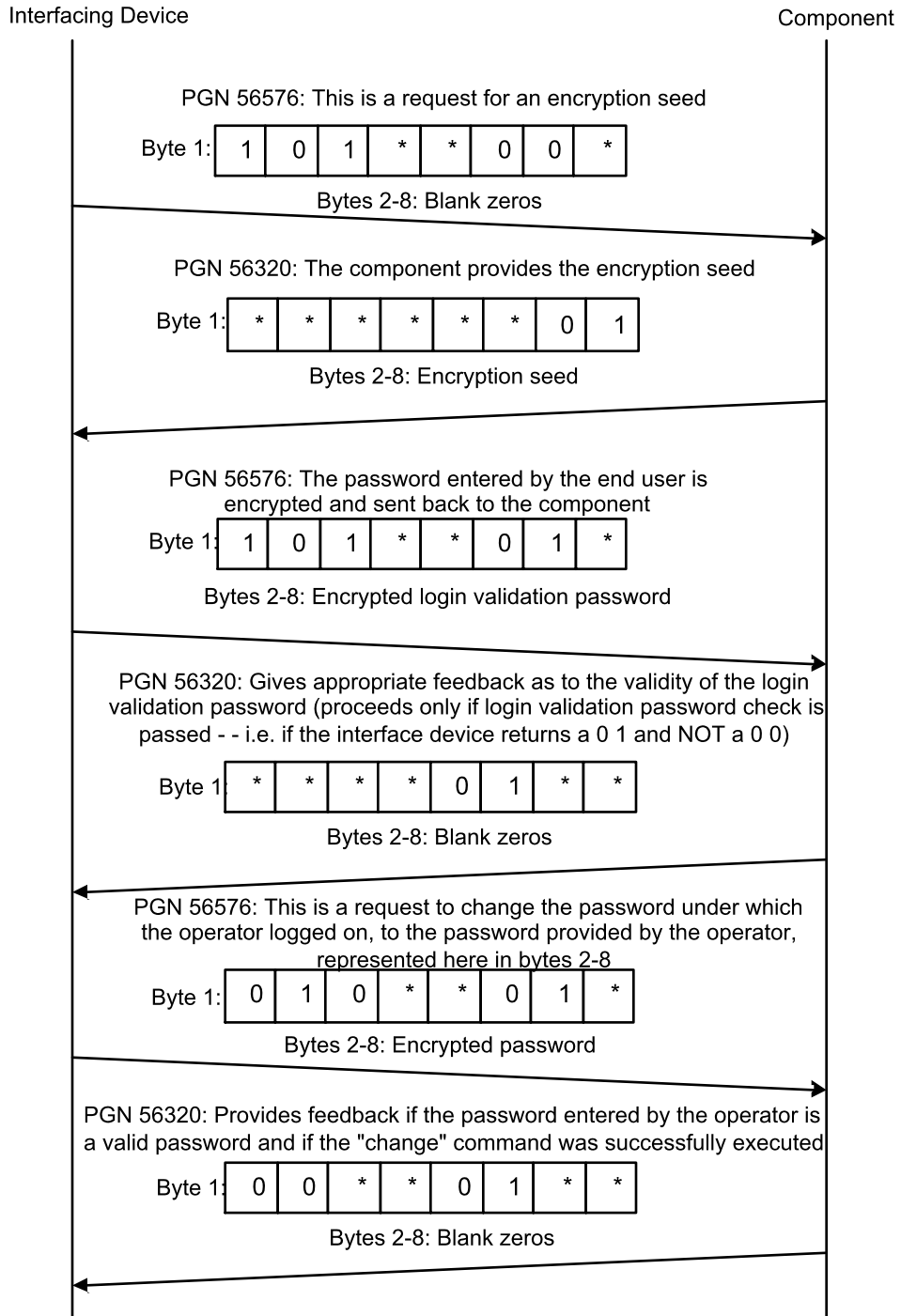

FIGURE PGN56320_C -- OPERATOR DESIRES TO CHANGE A PASSWORD WITHIN THE COMPONENT'S PASSWORD STRUCTURE

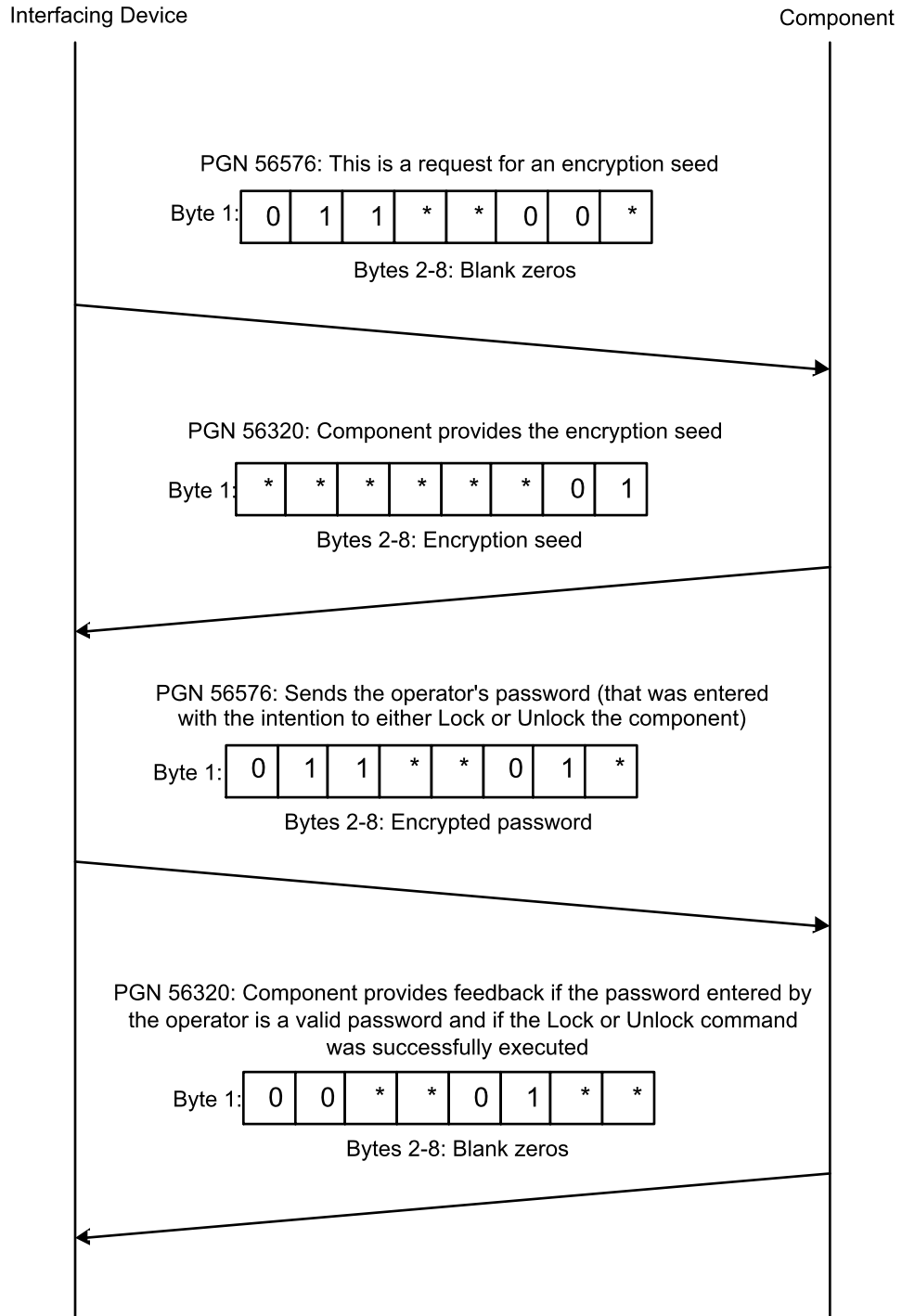

FIGURE PGN56320_D -- OPERATOR DESIRES TO LOCK OR UNLOCK THE COMPONENT

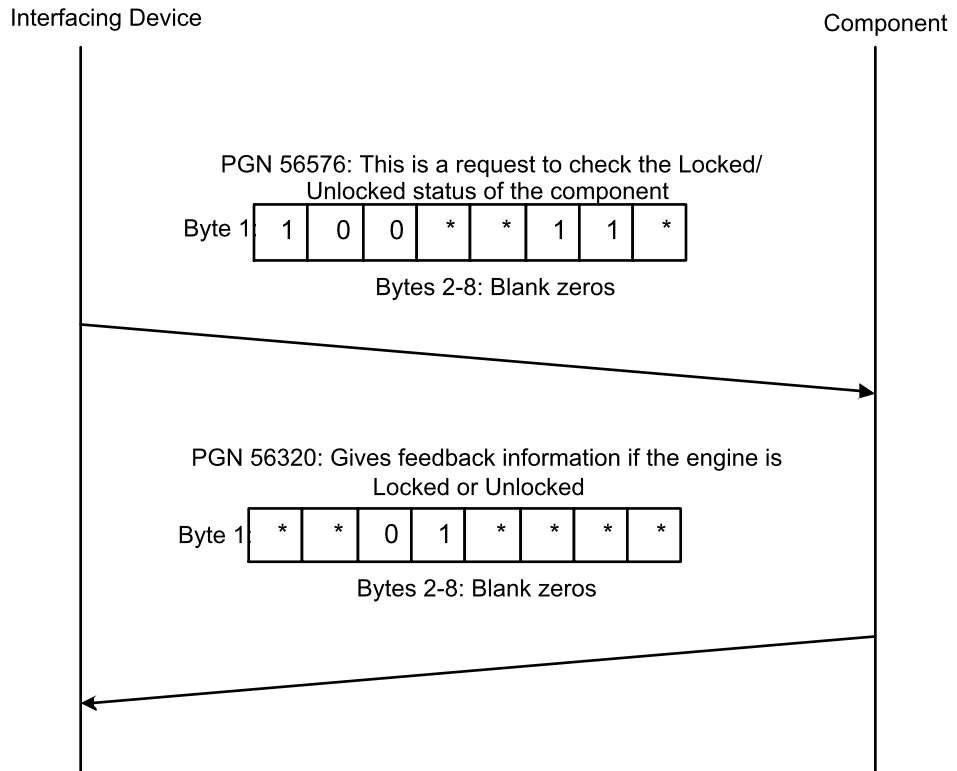

FIGURE PGN56320_E -- CHECKING STATUS OF THE COMPONENT

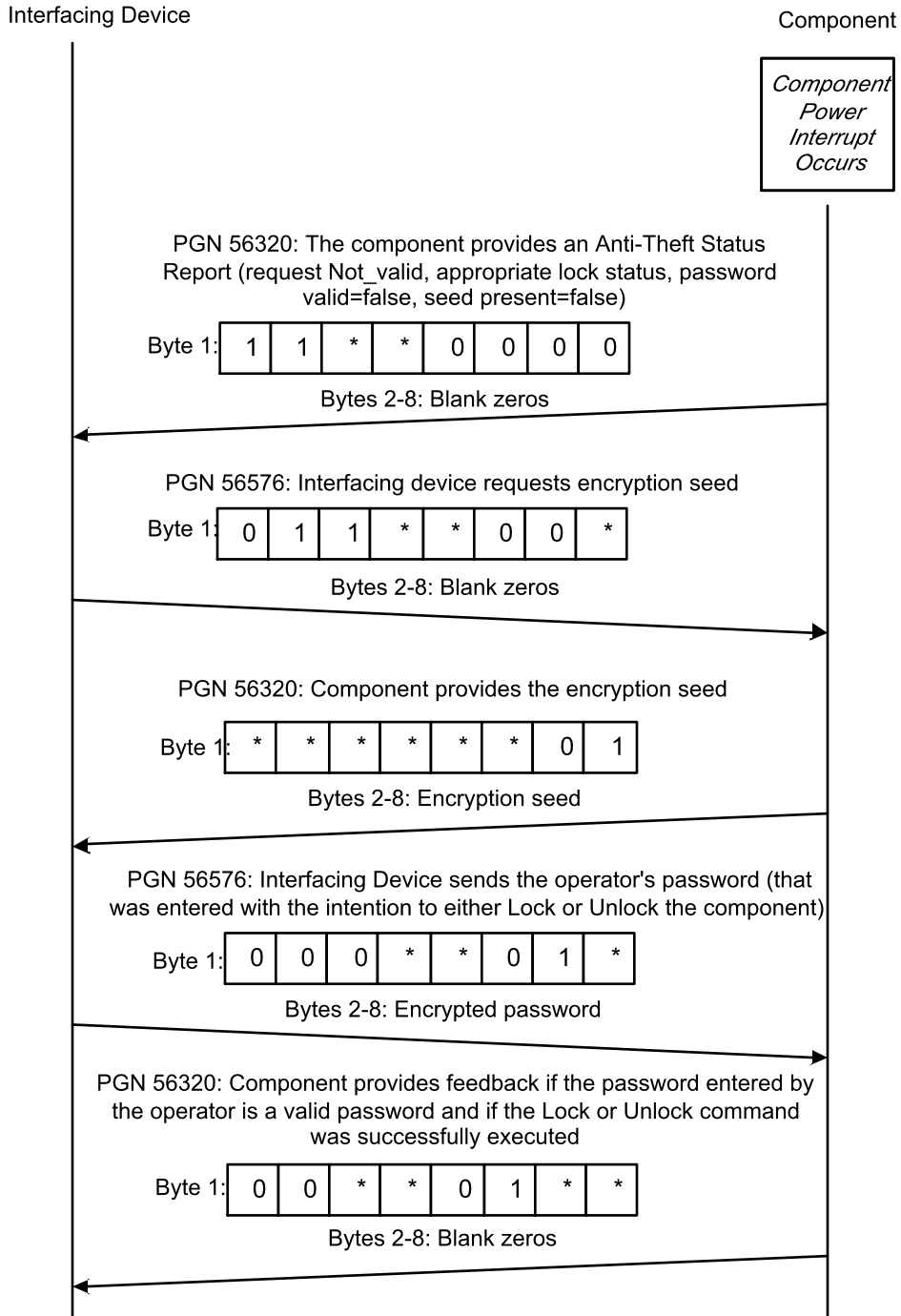

FIGURE PGN56320_F -- ABNORMAL COMPONENT POWER INTERRUPTION (INTERFACING DEVICE POWER IS NOT INTERRUPTED)

pgn56576 - Anti-theft Request - ATR -

Transmission Repetition Rate:

Transmission of this message is interrupt driven. This message is also transmitted upon power-up of the interfacing device this message.

Data Length:

8 bytes

Data Page:

0

PDU Format:		221	
PDU Specific:		DA	
Default Priority:		7	
Parameter Group Number:		56576 (00DD00 ₁₆)	
Bit Start Position /Bytes	Length	SPN Description	SPN
1.2	2 bits	Anti-theft Encryption Indicator States	1199
1.4	2 bits	Anti-theft Desired Exit Mode States	1200
1.6	3 bits	Anti-theft Command States	1201
2	7 bytes	Anti-theft Password Representation	1202

NOTE: See Figures PGN56320_A to PGN56320_F for examples of Anti-theft message transfers. Bit 1 is the right most bit in each byte.

pgn56832 - Reset - RESET -

Transmission Repetition Rate:		When needed	
Data Length:		8 bytes	
Data Page:		0	
PDU Format:		222	
PDU Specific:		DA	
Default Priority:		7	
Parameter Group Number:		56832 (00DE00 ₁₆)	
Bit Start Position /Bytes	Length	SPN Description	SPN
1.1	2 bits	Trip Group 1	988
1.3	2 bits	Trip Group 2 - Proprietary	989
2	1 byte	Service Component Identification	1584
3.1	2 bits	Engine Build Hours Reset	1211

NOTE: This message requires an Acknowledgement response (See J1939-21, PGN 59392) from the receiving node. The use of individual proprietary protocols can still be used instead of the "trip reset" PGN to maintain security.

pgn57344 - Cab Message 1 - CMI -

Transmission Repetition Rate:		1 s	
Data Length:		8 bytes	
Data Page:		0	
PDU Format:		224	
PDU Specific:		DA	
Default Priority:		6	
Parameter Group Number:		57344 (00E000 ₁₆)	
Bit Start Position /Bytes	Length	SPN Description	SPN
1	1 byte	Requested Percent Fan Speed	986
2-3	2 bytes	Cab Interior Temperature Command	1691
4.1	2 bits	Auxiliary Heater Coolant Pump Request	1684
4.3	2 bits	Battery Main Switch Hold Request	1682
4.5	2 bits	Operator Seat Direction Switch	1714
4.7	2 bits	Seat Belt Switch	1856
5.3	2 bits	Vehicle Limiting Speed Governor Decrement Switch	1655
5.5	2 bits	Vehicle Limiting Speed Governor Increment Switch	1654

5.7	2 bits	Vehicle Limiting Speed Governor Enable Switch	1653
6.5	2 bits	Automatic Gear Shifting Enable Switch	1666
6.7	2 bits	Engine Automatic Start Enable Switch	1656
7.1	4 bits	Auxiliary Heater Mode Request	1683
7.5	2 bits	Request Engine Zone Heating	1685
7.7	2 bits	Request Cab Zone Heating	1686
8	1 byte	Selected Maximum Vehicle Speed Limit	2596

Message containing parameters originating from the vehicle cab.

pgn61440 - Electronic Retarder Controller 1 - ERC1 -

Transmission Repetition Rate:		100 ms	
Data Length:		8 bytes	
Data Page:		0	
PDU Format:		240	
PDU Specific:		0	
Default Priority:		6	
Parameter Group Number:		61440 (00F000 ₁₆)	
Bit Start Position /Bytes	Length	SPN Description	SPN
1.1	4 bits	Retarder Torque Mode	900
1.5	2 bits	Retarder Enable - Brake Assist Switch	571
1.7	2 bits	Retarder Enable - Shift Assist Switch	572
2	1 byte	Actual Retarder - Percent Torque	520
3	1 byte	Intended Retarder Percent Torque	1085
4.1	2 bits	Engine Coolant Load Increase	1082
4.3	2 bits	Retarder Requesting Brake Light	1667
5	1 byte	Source Address of Controlling Device for Retarder Control	1480
6	1 byte	Drivers Demand Retarder - Percent Torque	1715
7	1 byte	Retarder Selection, non-engine	1716
8	1 byte	Actual Maximum Available Retarder - Percent Torque	1717

NOTE- This message will be transmitted by several types of retarding devices such as engine compression release brakes, exhaust system restriction brakes, and driveline retarders using hydraulic, electric, or mechanical friction to slow the vehicle. The source address of the message will indicate which one, and the type and location of the retarder are available in the Retarder Configuration Message (see PGN 65249) if that detail is important to the receiver. Users should also be aware that the Shift Assist and Brake Assist switch status in the first byte of this message are to be used by other ECUs that might request retarding force from the retarder to know when such assistance is available. The state of the 'switches' will NOT prevent the retarder from activating if requested, but should be honored by the requester (by not sending a request when the appropriate 'switch' is not enabled) to prevent unwarranted noise.

pgn61441 - Electronic Brake Controller 1 - EBC1 -

Transmission Repetition Rate:		100 ms
Data Length:		8 bytes
Data Page:		0
PDU Format:		240
PDU Specific:		1
Default Priority:		6
Parameter Group Number:		61441 (00F001 ₁₆)

Bit Start Position /Bytes	Length	SPN Description	SPN
1.1	2 bits	ASR Engine Control Active	561
1.3	2 bits	ASR Brake Control Active	562
1.5	2 bits	Anti-Lock Braking (ABS) Active	563
1.7	2 bits	EBS Brake Switch	1121
2	1 byte	Brake Pedal Position	521
3.1	2 bits	ABS Off-road Switch	575
3.3	2 bits	ASR Off-road Switch	576
3.5	2 bits	ASR "Hill Holder" Switch	577
3.7	2 bits	Traction Control Override Switch	1238
4.1	2 bits	Accelerator Interlock Switch	972
4.3	2 bits	Engine Derate Switch	971
4.5	2 bits	Auxiliary Engine Shutdown Switch	970
4.7	2 bits	Remote Accelerator Enable Switch	969
5	1 byte	Engine Retarder Selection	973
6.1	2 bits	ABS Fully Operational	1243
6.3	2 bits	EBS Red Warning Signal	1439
6.5	2 bits	ABS/EBS Amber Warning Signal (Powered Vehicle)	1438
6.7	2 bits	ATC/ASR Information Signal	1793
7	1 byte	Source Address of Controlling Device for Brake Control	1481
8.5	2 bits	Trailer ABS Status	1836
8.7	2 bits	Tractor-Mounted Trailer ABS Warning Signal	1792

Used for brake control information

pgn61442 - Electronic Transmission Controller 1 - ETC1 -

Transmission Repetition Rate:	10 ms
Data Length:	8 bytes
Data Page:	0
PDU Format:	240
PDU Specific:	2
Default Priority:	3
Parameter Group Number:	61442 (00F002 ₁₆)

Bit Start Position /Bytes	Length	SPN Description	SPN
1.1	2 bits	Driveline Engaged	560
1.3	2 bits	Torque Converter Lockup Engaged	573
1.5	2 bits	Shift In Process	574
2-3	2 bytes	Output Shaft Speed	191
4	1 byte	Percent Clutch Slip	522
5.1	2 bits	Momentary Engine Overspeed Enable	606
5.3	2 bits	Progressive Shift Disable	607
6-7	2 bytes	Input Shaft Speed	161
8	1 byte	Source Address of Controlling Device for Transmission Control	1482

pgn61443 - Electronic Engine Controller 2 - EEC2 -

Transmission Repetition Rate:	50 ms
-------------------------------	-------

Data Length:		8 bytes	
Data Page:		0	
PDU Format:		240	
PDU Specific:		3	
Default Priority:		3	
Parameter Group Number:		61443 (00F003 ₁₆)	
Bit Start Position /Bytes	Length	SPN Description	SPN
1.1	2 bits	Accelerator Pedal 1 Low Idle Switch	558
1.3	2 bits	Accelerator Pedal Kickdown Switch	559
1.5	2 bits	Road Speed Limit Status	1437
2	1 byte	Accelerator Pedal Position 1	91
3	1 byte	Percent Load At Current Speed	92
4	1 byte	Remote Accelerator Pedal Position	974

pgn61444 - Electronic Engine Controller 1 - EEC1 -

Transmission Repetition Rate:		engine speed dependent	
Data Length:		8 bytes	
Data Page:		0	
PDU Format:		240	
PDU Specific:		4	
Default Priority:		3	
Parameter Group Number:		61444 (00F004 ₁₆)	
Bit Start Position /Bytes	Length	SPN Description	SPN
1.1	4 bits	Engine Torque Mode	899
2	1 byte	Driver's Demand Engine - Percent Torque	512
3	1 byte	Actual Engine - Percent Torque	513
4-5	2 bytes	Engine Speed	190
6	1 byte	Source Address of Controlling Device for Engine Control	1483
7.1	4 bits	Engine Starter Mode	1675
8	1 byte	Engine Demand - Percent Torque	2432

Engine related parameters

pgn61445 - Electronic Transmission Controller 2 - ETC2 -

Transmission Repetition Rate:		100 ms	
Data Length:		8 bytes	
Data Page:		0	
PDU Format:		240	
PDU Specific:		5	
Default Priority:		6	
Parameter Group Number:		61445 (00F005 ₁₆)	
Bit Start Position /Bytes	Length	SPN Description	SPN
1	1 byte	Selected Gear	524
2-3	2 bytes	Actual Gear Ratio	526
4	1 byte	Current Gear	523
5-6	2 bytes	Transmission Requested Range	162

7-8 2 bytes Transmission Current Range 163

pgn61446 - Electronic Axle Controller 1 - EAC1 -

Transmission Repetition Rate:	500 ms		
Data Length:	8 bytes		
Data Page:	0		
PDU Format:	240		
PDU Specific:	6		
Default Priority:	6		
Parameter Group Number:	61446 (00F006 ₁₆)		
Bit Start Position /Bytes	Length	SPN Description	SPN
1	8 bits	Location	927
2.1	2 bits	Differential Lock State - Front Axle 1	567
2.3	2 bits	Differential Lock State - Front Axle 2	568
2.5	2 bits	Differential Lock State - Rear Axle 1	569
2.7	2 bits	Differential Lock State - Rear Axle 2	570
3.1	2 bits	Differential Lock State - Central	564
3.3	2 bits	Differential Lock State - Central Front	565
3.5	2 bits	Differential Lock State - Central Rear	566

NOTE: Request has to be responded to with as many messages as necessary to transmit all available information.

pgn61447 - Forward Lane Image urgent msg - FLII -

Transmission Repetition Rate:	50 ms (only when active)		
Data Length:	8 bytes		
Data Page:	0		
PDU Format:	240		
PDU Specific:	7		
Default Priority:	4		
Parameter Group Number:	61447 (00F007 ₁₆)		
Bit Start Position /Bytes	Length	SPN Description	SPN
1.5	2 bits	Lane Departure Imminent, Right Side	1701
1.7	2 bits	Lane Departure Imminent, Left Side	1700

pgn61448 - Hydraulic Pressure Governor Info - HPG -

Transmission Repetition Rate:	50 ms		
Data Length:	8 bytes		
Data Page:	0		
PDU Format:	240		
PDU Specific:	8		
Default Priority:	6		
Parameter Group Number:	61448 (00F008 ₁₆)		
Bit Start Position /Bytes	Length	SPN Description	SPN
1-2	2 bytes	Hydraulic Pressure	1762
3.1	2 bits	Hydraulic Pressure Mode Indicator	1763
3.3	2 bits	Hydraulic Pressure Governor Switch	1764

3.5 2 bits Fire Apparatus Pump Engagement 2599
 Information to be used for a hydraulic pressure governing control system

pgn61449 - Vehicle Dynamic Stability Control 2 - VDC2 -

Transmission Repetition Rate: 10 ms
 Data Length: 8 bytes
 Data Page: 0
 PDU Format: 240
 PDU Specific: 9
 Default Priority: 6
 Parameter Group Number: 61449 (00F009₁₆)
 Bit Start Position /Bytes Length SPN Description SPN
 1-2 2 bytes Steering Wheel Angle 1807
 3.1 6 bits Steering Wheel Turn Counter 1811
 3.7 2 bits Steering Wheel Angle Sensor Type 1812
 4-5 2 bytes Yaw Rate 1808
 6-7 2 bytes Lateral Acceleration 1809
 8 1 byte Longitudinal Acceleration 1810

Contains information which relates to the vehicle's movement.

pgn61450 - Engine Gas Flow Rate - EGF1 -

Transmission Repetition Rate: 50 ms
 Data Length: 8 bytes
 Data Page: 0
 PDU Format: 240
 PDU Specific: 10
 Default Priority: 3
 Parameter Group Number: 61450 (00F00A₁₆)
 Bit Start Position /Bytes Length SPN Description SPN
 1-2 2 bytes EGR Mass Flow Rate 2659
 3-4 2 bytes Inlet Air Mass Flow Rate 132

Flow rates of Air and mixed gasses into the engine cylinders.

pgn64977 - FMS-standard Interface Identity/Capabilities - FMS -

Transmission Repetition Rate: 10 s
 Data Length: 8 bytes
 Data Page: 0
 PDU Format: 253
 PDU Specific: 209
 Default Priority: 7
 Parameter Group Number: 64977 (00FDD1₁₆)
 Bit Start Position /Bytes Length SPN Description SPN
 1.1 2 bits FMS-standard Diagnostics Supported 2804
 1.3 2 bits FMS-standard Requests Supported 2805
 2-5 4 bytes FMS-standard SW-version supported. 2806

Information which specifies the capabilities of the Fleet Management System (FMS) - standard interface device. This PGN typically is sourced from the network interconnect FMS - standard interface device.

pgn64978 - ECU Performance - EP -

Transmission Repetition Rate:	On request		
Data Length:	8 bytes		
Data Page:	0		
PDU Format:	253		
PDU Specific:	210		
Default Priority:	6		
Parameter Group Number:	64978 (00FDD2 ₁₆)		
Bit Start Position /Bytes	Length	SPN Description	SPN
1-2	2 bytes	Keep-Alive Battery Consumption	2803
3	1 byte	Data Memory Usage	2802

Message used to transfer ECU performance parameters.

pgn64979 - Turbocharger Information 6 - TCI6 -

Transmission Repetition Rate:	1 s		
Data Length:	8 bytes		
Data Page:	0		
PDU Format:	253		
PDU Specific:	211		
Default Priority:	6		
Parameter Group Number:	64979 (00FDD3 ₁₆)		
Bit Start Position /Bytes	Length	SPN Description	SPN
1-2	2 bytes	Turbocharger 1 Compressor Outlet Temperature	2629
3-4	2 bytes	Turbocharger 2 Compressor Outlet Temperature	2799
5-6	2 bytes	Turbocharger 3 Compressor Outlet Temperature	2800
7-8	2 bytes	Turbocharger 4 Compressor Outlet Temperature	2801

Turbocharger Compressor Outlet Discharge Temperature

pgn64980 - Cab Message 3 - CM3 -

Transmission Repetition Rate:	On-change or every 10 s		
Data Length:	8 bytes		
Data Page:	0		
PDU Format:	253		
PDU Specific:	212		
Default Priority:	6		
Parameter Group Number:	64980 (00FDD4 ₁₆)		
Bit Start Position /Bytes	Length	SPN Description	SPN
1.1	3 bits	Transfer Case Selector Switch	2796

Provides information from Cab mounted operator inputs.

pgn64981 - Electronic Engine Controller 5 - EEC5 -

Transmission Repetition Rate:	On request		
Data Length:	8 bytes		
Data Page:	0		
PDU Format:	253		
PDU Specific:	213		
Default Priority:	6		
Parameter Group Number:	64981 (00FDD5 ₁₆)		
Bit Start Position /Bytes	Length	SPN Description	SPN
1-2	2 bytes	Calculated Turbocharger 1 Turbine Inlet Temperature	2789
3-4	2 bytes	Calculated Turbocharger 1 Compressor Outlet Temperature	2790
5-6	2 bytes	Exhaust Gas Recirculation (EGR) Valve Control	2791
7.1	2 bits	Variable Geometry Turbocharger (VGT) Air Control Shutoff Valve	2792
8	1 byte	VGT 1 Actuator Position	2795

Engine related parameters

pgn64982 - Basic Joystick Message 1 - BJM1 -

Transmission Repetition Rate:	100 ms or on change, not to exceed 20 ms		
Data Length:	8 bytes		
Data Page:	0		
PDU Format:	253		
PDU Specific:	214		
Default Priority:	3		
Parameter Group Number:	64982 (00FDD6 ₁₆)		
Bit Start Position /Bytes	Length	SPN Description	SPN
1.1	2 bits	Joystick 1 X-Axis Neutral Position Status	2675
1.3	2 bits	Joystick 1 X-Axis Lever Left Negative Position Status	2670
1.5	2 bits	Joystick 1 X-Axis Lever Right Positive Position Status	2665
1.7-2	10 bits	Joystick 1 X-Axis Position	2660
3.1	2 bits	Joystick 1 Y-Axis Neutral Position Status	2676
3.3	2 bits	Joystick 1 Y-Axis Lever Back Negative Position Status	2671
3.5	2 bits	Joystick 1 Y-Axis Lever Forward Positive Position Status	2666
3.7-4	10 bits	Joystick 1 Y-Axis Position	2661
5.5	2 bits	Joystick 1 Y-Axis Detent Position Status	2681
5.7	2 bits	Joystick 1 X-Axis Detent Position Status	2680
6.1	2 bits	Joystick 1 Button 4 Pressed Status	2688
6.3	2 bits	Joystick 1 Button 3 Pressed Status	2687
6.5	2 bits	Joystick 1 Button 2 Pressed Status	2686
6.7	2 bits	Joystick 1 Button 1 Pressed Status	2685
7.1	2 bits	Joystick 1 Button 8 Pressed Status	2692
7.3	2 bits	Joystick 1 Button 7 Pressed Status	2691
7.5	2 bits	Joystick 1 Button 6 Pressed Status	2690
7.7	2 bits	Joystick 1 Button 5 Pressed Status	2689
8.1	2 bits	Joystick 1 Button 12 Pressed Status	2696
8.3	2 bits	Joystick 1 Button 11 Pressed Status	2695
8.5	2 bits	Joystick 1 Button 10 Pressed Status	2694

8.7	2 bits	Joystick 1 Button 9 Pressed Status	2693
-----	--------	------------------------------------	------

Used to transfer information about the measured status of the 1st 2 axes and up to 12 buttons of a joystick. Additional handle information is available in the Expanded Joystick Message.

10-bit position parameters are broadcast over 2 bytes. The eight most significant bits are transmitted in the second byte, with the most significant bit at bit 8. The two least significant bits are transmitted in the first byte in bit positions 7 and 8, with the most significant of the two bits at bit 8.

10-bit position SPN	Location in PGN	
Bit 10	Byte n	Bit 8
Bit 9		Bit 7
Bit 8		Bit 6
Bit 7		Bit 5
Bit 6		Bit 4
Bit 5		Bit 3
Bit 4		Bit 2
Bit 3		Bit 1
Bit 2	Byte (n-1)	Bit 8
Bit 1		Bit 7

pgn64983 - Extended Joystick Message 1 - EJMI -

Transmission Repetition Rate:	100 ms or on change, not to exceed 20 ms
Data Length:	8 bytes
Data Page:	0
PDU Format:	253
PDU Specific:	215
Default Priority:	3
Parameter Group Number:	64983 (00FDD7 ₁₆)

Bit Start Position /Bytes	Length	SPN Description	SPN
1.1	2 bits	Joystick 1 Grip X-Axis Neutral Position Status	2677
1.3	2 bits	Joystick 1 Grip X-Axis Lever Left Negative Position Status	2672
1.5	2 bits	Joystick 1 Grip X-Axis Lever Right Positive Position Status	2667
1.7-2	10 bits	Joystick 1 Grip X-Axis Position	2662
3.1	2 bits	Joystick 1 Grip Y-Axis Neutral Position Status	2678
3.3	2 bits	Joystick 1 Grip Y-Axis Lever Back Negative Position Status	2673
3.5	2 bits	Joystick 1 Grip Y-Axis Lever Forward Positive Position Status	2668
3.7-4	10 bits	Joystick 1 Grip Y-Axis Position	2663
5.1	2 bits	Joystick 1 Theta-Axis Neutral Position Status	2679
5.3	2 bits	Joystick 1 Theta-Axis Counter Clockwise Negative Position Status	2674
5.5	2 bits	Joystick 1 Theta-Axis Clockwise Positive Position Status	2669
5.7-6	10 bits	Joystick 1 Theta-Axis Position	2664
7.3	2 bits	Joystick 1 Theta-Axis Detent Position Status	2684
7.5	2 bits	Joystick 1 Grip Y-Axis Detent Position Status	2683
7.7	2 bits	Joystick 1 Grip X-Axis Detent Position Status	2682

Used to transfer information about the measured status of three additional axes of a joystick and switches of the joystick grip or handle. The joystick axial motion information is available in the Basic Joystick Message.

10-bit position parameters are broadcast over 2 bytes. The eight most significant bits are transmitted in the second byte, with the most significant bit at bit 8. The two least significant bits are transmitted in the first byte in bit positions 7 and 8, with the most significant of the two bits at bit 8.

10-bit position SPN	Location in PGN	
Bit 10	Byte n	Bit 8
Bit 9		Bit 7
Bit 8		Bit 6
Bit 7		Bit 5
Bit 6		Bit 4
Bit 5		Bit 3
Bit 4		Bit 2
Bit 3		Bit 1

pgn64985 - Extended Joystick Message 2 - EJM2 -

Transmission Repetition Rate: 100 ms or on change, not to exceed 20 ms
 Data Length: 8 bytes
 Data Page: 0
 PDU Format: 253
 PDU Specific: 217
 Default Priority: 3
 Parameter Group Number: 64985 (00FDD9₁₆)

Bit Start Position /Bytes	Length	SPN Description	SPN
1.1	2 bits	Joystick 2 Grip X-Axis Neutral Position Status	2714
1.3	2 bits	Joystick 2 Grip X-Axis Lever Left Negative Position Status	2709
1.5	2 bits	Joystick 2 Grip X-Axis Lever Right Positive Position Status	2704
1.7-2	10 bits	Joystick 2 Grip X-Axis Position	2699
3.1	2 bits	Joystick 2 Grip Y-Axis Neutral Position Status	2715
3.3	2 bits	Joystick 2 Grip Y-Axis Lever Back Negative Position Status	2710
3.5	2 bits	Joystick 2 Grip Y-Axis Lever Forward Positive Position Status	2705
3.7-4	10 bits	Joystick 2 Grip Y-Axis Position	2700
5.1	2 bits	Joystick 2 Theta-Axis Neutral Position Status	2716
5.3	2 bits	Joystick 2 Theta-Axis Counter Clockwise Negative Position Status	2711
5.5	2 bits	Joystick 2 Theta-Axis Clockwise Positive Position Status	2706
5.7-6	10 bits	Joystick 2 Theta-Axis Position	2701
7.3	2 bits	Joystick 2 Theta-Axis Detent Position Status	2721
7.5	2 bits	Joystick 2 Grip Y-Axis Detent Position Status	2720
7.7	2 bits	Joystick 2 Grip X-Axis Detent Position Status	2719

Used to transfer information about the measured status of three additional axes of a joystick and switches of the joystick grip or handle. The joystick axial motion information is available in the Basic Joystick Message.

10-bit position parameters are broadcast over 2 bytes. The eight most significant bits are transmitted in the second byte, with the most significant bit at bit 8. The two least significant bits are transmitted in the first byte in bit positions 7 and 8, with the most significant of the two bits at bit 8.

10-bit position SPN	Location in PGN	
Bit 10	Byte n	Bit 8
Bit 9		Bit 7
Bit 8		Bit 6
Bit 7		Bit 5
Bit 6		Bit 4
Bit 5		Bit 3
Bit 4		Bit 2
Bit 3		Bit 1
Bit 2	Byte (n-1)	Bit 8
Bit 1		Bit 7

Note: The term Grip used here simply refers to another set of axes separate from the previously mentioned X and Y Axis. This additional set of axes could in some cases be grip mounted sensors as opposed to the sensors mounted at the base of the handle.

pgn64986 - Basic Joystick Message 3 - BJM3 -

Transmission Repetition Rate: 100 ms or on change, not to exceed 20 ms
 Data Length: 8 bytes
 Data Page: 0
 PDU Format: 253
 PDU Specific: 218
 Default Priority: 3

Parameter Group Number: 64986 (00FDDA₁₆)

Bit Start Position /Bytes	Length	SPN Description	SPN
1.1	2 bits	Joystick 3 X-Axis Neutral Position Status	2749
1.3	2 bits	Joystick 3 X-Axis Lever Left Negative Position Status	2744
1.5	2 bits	Joystick 3 X-Axis Lever Right Positive Position Status	2739
1.7-2	10 bits	Joystick 3 X-Axis Position	2734
3.1	2 bits	Joystick 3 Y-Axis Neutral Position Status	2750
3.3	2 bits	Joystick 3 Y-Axis Lever Back Negative Position Status	2745
3.5	2 bits	Joystick 3 Y-Axis Lever Forward Positive Position Status	2740
3.7-4	10 bits	Joystick 3 Y-Axis Position	2735
5.5	2 bits	Joystick 3 Y-Axis Detent Position Status	2755
5.7	2 bits	Joystick 3 X-Axis Detent Position Status	2754
6.1	2 bits	Joystick 3 Button 4 Pressed Status	2762
6.3	2 bits	Joystick 3 Button 3 Pressed Status	2761
6.5	2 bits	Joystick 3 Button 2 Pressed Status	2760
6.7	2 bits	Joystick 3 Button 1 Pressed Status	2759
7.1	2 bits	Joystick 3 Button 8 Pressed Status	2766
7.3	2 bits	Joystick 3 Button 7 Pressed Status	2765
7.5	2 bits	Joystick 3 Button 6 Pressed Status	2764
7.7	2 bits	Joystick 3 Button 5 Pressed Status	2763
8.1	2 bits	Joystick 3 Button 12 Pressed Status	2770
8.3	2 bits	Joystick 3 Button 11 Pressed Status	2769
8.5	2 bits	Joystick 3 Button 10 Pressed Status	2768
8.7	2 bits	Joystick 3 Button 9 Pressed Status	2767

Used to transfer information about the measured status of the 1st 2 axes and up to 12 buttons of a joystick. Additional handle information is available in the Expanded Joystick Message.

10-bit position parameters are broadcast over 2 bytes. The eight most significant bits are transmitted in the second byte, with the most significant bit at bit 8. The two least significant bits are transmitted in the first byte in bit positions 7 and 8, with the most significant of the two bits at bit 8.

10-bit position SPN	Location in PGN	
Bit 10	Byte n	Bit 8
Bit 9		Bit 7
Bit 8		Bit 6
Bit 7		Bit 5
Bit 6		Bit 4
Bit 5		Bit 3
Bit 4		Bit 2
Bit 3		Bit 1
Bit 2	Byte (n-1)	Bit 8
Bit 1		Bit 7

pgn64987 - Extended Joystick Message 3 - EJM3 -

Transmission Repetition Rate: 100 ms or on change, not to exceed 20 ms

Data Length: 8 bytes

Data Page: 0

PDU Format: 253

PDU Specific: 219

Default Priority: 3

Parameter Group Number: 64987 (00FDDDB₁₆)

Bit Start Position /Bytes	Length	SPN Description	SPN
1.1	2 bits	Joystick 3 Grip X-Axis Neutral Position Status	2751

1.3	2 bits	Joystick 3 Grip X-Axis Lever Left Negative Position Status	2746
1.5	2 bits	Joystick 3 Grip X-Axis Lever Right Positive Position Status	2741
1.7-2	10 bits	Joystick 3 Grip X-Axis Position	2736
3.1	2 bits	Joystick 3 Grip Y-Axis Neutral Position Status	2752
3.3	2 bits	Joystick 3 Grip Y-Axis Lever Back Negative Position Status	2747
3.5	2 bits	Joystick 3 Grip Y-Axis Lever Forward Positive Position Status	2742
3.7-4	10 bits	Joystick 3 Grip Y-Axis Position	2737
5.1	2 bits	Joystick 3 Theta-Axis Neutral Position Status	2753
5.3	2 bits	Joystick 3 Theta-Axis Counter Clockwise Negative Position Status	2748
5.5	2 bits	Joystick 3 Theta-Axis Clockwise Positive Position Status	2743
5.7-6	10 bits	Joystick 3 Theta-Axis Position	2738
7.3	2 bits	Joystick 3 Theta-Axis Detent Position Status	2758
7.5	2 bits	Joystick 3 Grip Y-Axis Detent Position Status	2757
7.7	2 bits	Joystick 3 Grip X-Axis Detent Position Status	2756

Used to transfer information about the measured status of three additional axes of a joystick and switches of the joystick grip or handle. The joystick axial motion information is available in the Basic Joystick Message.

10-bit position parameters are broadcast over 2 bytes. The eight most significant bits are transmitted in the second byte, with the most significant bit at bit 8. The two least significant bits are transmitted in the first byte in bit positions 7 and 8, with the most significant of the two bits at bit 8.

10-bit position SPN	Location in PGN	
Bit 10	Byte n	Bit 8
Bit 9		Bit 7
Bit 8		Bit 6
Bit 7		Bit 5
Bit 6		Bit 4
Bit 5		Bit 3
Bit 4		Bit 2
Bit 3		Bit 1
Bit 2	Byte (n-1)	Bit 8
Bit 1		Bit 7

Note: The term Grip used here simply refers to another set of axes separate from the previously mentioned X and Y Axis. This additional set of axes could in some cases be grip mounted sensors as opposed to the sensors mounted at the base of the handle.

pgn64988 - Marine Control Information - MCI -

Transmission Repetition Rate:	1 s		
Data Length:	8 bytes		
Data Page:	0		
PDU Format:	253		
PDU Specific:	220		
Default Priority:	6		
Parameter Group Number:	64988 (00FDDC ₁₆)		
Bit Start Position /Bytes	Length	SPN Description	SPN
1.1	4 bits	Throttle Synchronization Mode Status	2615
1.5	2 bits	Trolling Mode Status	2616
1.7	2 bits	Slow Vessel Mode Status	2617

This messages contains marine vessel control information for the engine

pgn64991 - Front Wheel Drive Status - FWD -

Transmission Repetition Rate:	0.5 s
Data Length:	8 bytes
Data Page:	0

PDU Format:	253		
PDU Specific:	223		
Default Priority:	7		
Parameter Group Number:	64991 (00FDDF ₁₆)		
Bit Start Position /Bytes	Length	SPN Description	SPN
1.1	2 bits	Front Wheel Drive Actuator Status	2612

Front wheel drive ECU information

pgn64992 - Ambient Conditions 2 - AMB2 -

Transmission Repetition Rate:	1 s		
Data Length:	8 bytes		
Data Page:	0		
PDU Format:	253		
PDU Specific:	224		
Default Priority:	6		
Parameter Group Number:	64992 (00FDE0 ₁₆)		
Bit Start Position /Bytes	Length	SPN Description	SPN
1	1 byte	Solar Intensity Percent	2610
2	1 byte	Solar Sensor Maximum	2611

This message contains measurement and configuration information about the vehicle ambient conditions.

pgn64993 - Cab A/C Climate System Information - CACI -

Transmission Repetition Rate:	1 s		
Data Length:	8 bytes		
Data Page:	0		
PDU Format:	253		
PDU Specific:	225		
Default Priority:	6		
Parameter Group Number:	64993 (00FDE1 ₁₆)		
Bit Start Position /Bytes	Length	SPN Description	SPN
1	1 byte	Cab A/C Refrigerant Compressor Outlet Pressure	2609

This message contains measurement and condition information from cab air conditioning components.

pgn64994 - Supply Pressure Demand - SPR -

Transmission Repetition Rate:	1 s, when active		
Data Length:	8 bytes		
Data Page:	0		
PDU Format:	253		
PDU Specific:	226		
Default Priority:	6		
Parameter Group Number:	64994 (00FDE2 ₁₆)		
Bit Start Position /Bytes	Length	SPN Description	SPN
1	1 byte	Pneumatic Supply Pressure Request	2603
2	1 byte	Parking and/or Trailer Air Pressure Request	2604
3	1 byte	Service Brake Air Pressure Request, Circuit #1	2605

4	1 byte	Service Brake Air Pressure Request, Circuit #2	2606
5	1 byte	Auxiliary Equipment Supply Pressure Request	2607
6	1 byte	Air Suspension Supply Pressure Request	2608

Used for controlling the supply pressure. Often used to raise the pressure of a supply pressure circuit in situations where more pneumatic energy is needed. This message is the setpoint for the PGN 65198 message.

pgn64995 - Equipment Operation and Control - EOAC -

Transmission Repetition Rate:	250 mS		
Data Length:	8 bytes		
Data Page:	0		
PDU Format:	253		
PDU Specific:	227		
Default Priority:	6		
Parameter Group Number:	64995 (00FDE3 ₁₆)		
Bit Start Position /Bytes	Length	SPN Description	SPN
1	1 byte	Travel Velocity Control Position	2601

Parameters related to the operation and controls for equipment

pgn64996 - Equipment Performance Data - EPD -

Transmission Repetition Rate:	500 mS		
Data Length:	8 bytes		
Data Page:	0		
PDU Format:	253		
PDU Specific:	228		
Default Priority:	6		
Parameter Group Number:	64996 (00FDE4 ₁₆)		
Bit Start Position /Bytes	Length	SPN Description	SPN
1	1 byte	Payload Percentage	2600

Parameters related to the performance characteristics of equipment

pgn64997 - Maximum Vehicle Speed Limit Status - MVS -

Transmission Repetition Rate:	1 s		
Data Length:	8 bytes		
Data Page:	0		
PDU Format:	253		
PDU Specific:	229		
Default Priority:	6		
Parameter Group Number:	64997 (00FDE5 ₁₆)		
Bit Start Position /Bytes	Length	SPN Description	SPN
1	1 byte	Maximum Vehicle Speed Limit 1	2588
2	1 byte	Maximum Vehicle Speed Limit 2	2589
3	1 byte	Maximum Vehicle Speed Limit 3	2590
4	1 byte	Maximum Vehicle Speed Limit 4	2591
5	1 byte	Maximum Vehicle Speed Limit 5	2592
6	1 byte	Maximum Vehicle Speed Limit 6	2593

7	1 byte	Maximum Vehicle Speed Limit 7	2594
8	1 byte	Applied Vehicle Speed Limit	2595

Reports the possible maximum vehicle speed limits, one through seven, and the applied maximum vehicle speed limit.

pgn64998 - Hydraulic Braking System - HBS -

Transmission Repetition Rate:	100 ms		
Data Length:	8 bytes		
Data Page:	0		
PDU Format:	253		
PDU Specific:	230		
Default Priority:	3		
Parameter Group Number:	64998 (00FDE6 ₁₆)		
Bit Start Position /Bytes	Length	SPN Description	SPN
1	1 byte	Hydraulic Brake Pressure Circuit 1	2580
2	1 byte	Hydraulic Brake Pressure Circuit 2	2581
3.1	2 bits	Hydraulic Brake Pressure Warning State Circuit 1	2584
3.3	2 bits	Hydraulic Brake Pressure Warning State Circuit 2	2585
3.5	2 bits	Hydraulic Brake Pressure Supply State Circuit 1	2582
3.7	2 bits	Hydraulic Brake Pressure Supply State Circuit 2	2583

Used for information on a hydraulic brake system. As an example: this PGN may be used for a two circuit hydraulic brake system with separate circuits for front and rear axle. The hydraulic energy is supplied via two independent electrically driven pumps. The energy is stored in gas filled hydraulic accumulators also separated for each circuit.

pgn65031 - Exhaust Temperature - ET -

Transmission Repetition Rate:	0.5 s		
Data Length:	8 bytes		
Data Page:	0		
PDU Format:	254		
PDU Specific:	7		
Default Priority:	6		
Parameter Group Number:	65031 (00FE07 ₁₆)		
Bit Start Position /Bytes	Length	SPN Description	SPN
1-2	2 bytes	Right Manifold Exhaust Gas Temperature	2433
3-4	2 bytes	Left Manifold Exhaust Gas Temperature	2434

pgn65088 - Lighting Data - LD -

Transmission Repetition Rate:	As requested.		
Data Length:	8 bytes		
Data Page:	0		
PDU Format:	254		
PDU Specific:	64		
Default Priority:	6		
Parameter Group Number:	65088 (00FE40 ₁₆)		
Bit Start Position /Bytes	Length	SPN Description	SPN
1.1	2 bits	Running Light	2404

1.3	2 bits	Alternate Beam Head Light Data	2352
1.5	2 bits	Low Beam Head Light Data	2350
1.7	2 bits	High Beam Head Light Data	2348
2.1	2 bits	Tractor Front Fog Lights	2388
2.3	2 bits	Rotating Beacon Light	2386
2.5	2 bits	Right Turn Signal Lights	2370
2.7	2 bits	Left Turn Signal Lights	2368
3.1	2 bits	Back Up Light and Alarm Horn	2392
3.3	2 bits	Center Stop Light	2376
3.5	2 bits	Right Stop Light	2374
3.7	2 bits	Left Stop Light	2372
4.1	2 bits	Implement Clearance Light	2384
4.3	2 bits	Tractor Clearance Light	2382
4.5	2 bits	Implement Marker Light	2380
4.7	2 bits	Tractor Marker Light	2378
5.1	2 bits	Rear Fog Lights	2390
5.3	2 bits	Tractor Underside Mounted Work Lights	2358
5.5	2 bits	Tractor Rear Low Mounted Work Lights	2360
5.7	2 bits	Tractor Rear High Mounted Work Lights	2362
6.1	2 bits	Tractor Side Low Mounted Work Lights	2364
6.3	2 bits	Tractor Side High Mounted Work Lights	2366
6.5	2 bits	Tractor Front Low Mounted Work Lights	2354
6.7	2 bits	Tractor Front High Mounted Work Lights	2356
7.1	2 bits	Implement OEM Option 2 Light	2398
7.3	2 bits	Implement OEM Option 1 Light	2396
7.5	2 bits	Implement Right Facing Work Light	2407
7.7	2 bits	Implement Left Facing Work Light	2598
8.3	2 bits	Implement Right Forward Work Light	2402
8.5	2 bits	Implement Left Forward Work Light	2400
8.7	2 bits	Implement Rear Work Light	2394

This lighting message is a response to the request for lighting data in the lighting command message. Each lighting controller on the tractor and attached implements must transmit this message to the Tractor ECU when requested. The tractor will use this information to determine which lighting systems are functioning. Lighting controllers that have lamp sensing capability will also report failed light bulbs. This is a legal requirement in many areas. See PGN 65089 for the lighting command message.

pgn65089 - Lighting Command - LC -

Transmission Repetition Rate:	On change of lamp on/ off state. Maximum period of 1 second between messages. No greater than 10 messages per second
	lights.
Data Length:	8 bytes
Data Page:	0
PDU Format:	254
PDU Specific:	65
Default Priority:	3
Parameter Group Number:	65089 (00FE41 ₁₆)
Bit Start Position /Bytes Length	SPN Description
	SPN

1.1	2 bits	Running Light Command	2403
1.3	2 bits	Alternate Beam Head Light Command	2351
1.5	2 bits	Low Beam Head Light Command	2349
1.7	2 bits	High Beam Head Light Command	2347
2.1	2 bits	Tractor Front Fog Lights Command	2387
2.3	2 bits	Rotating Beacon Light Command	2385
2.5	2 bits	Right Turn Signal Lights Command	2369
2.7	2 bits	Left Turn Signal Lights Command	2367
3.1	2 bits	Back Up Light and Alarm Horn Command	2391
3.3	2 bits	Center Stop Light Command	2375
3.5	2 bits	Right Stop Light Command	2373
3.7	2 bits	Left Stop Light Command	2371
4.1	2 bits	Implement Clearance Light Command	2383
4.3	2 bits	Tractor Clearance Light Command	2381
4.5	2 bits	Implement Marker Light Command	2379
4.7	2 bits	Tractor Marker Light Command	2377
5.1	2 bits	Rear Fog Light Command	2389
5.3	2 bits	Tractor Underside Mounted Work Lights Command	2357
5.5	2 bits	Tractor Rear Low Mounted Work Lights Command	2359
5.7	2 bits	Tractor Rear High Mounted Work Lights Command	2361
6.1	2 bits	Tractor Side Low Mounted Work Lights Command	2363
6.3	2 bits	Tractor Side High Mounted Work Lights Command	2365
6.5	2 bits	Tractor Front Low Mounted Work Lights Command	2353
6.7	2 bits	Tractor Front High Mounted Work Lights Command	2355
7.1	2 bits	Implement OEM Option 2 Light Command	2397
7.3	2 bits	Implement OEM Option 1 Light Command	2395
7.5	2 bits	Implement Right Facing Work Light Command	2406
7.7	2 bits	Implement Left Facing Work Light Command	2597
8.1	2 bits	Lighting Data Request Command	2393
8.3	2 bits	Implement Right Forward Work Light Command	2401
8.5	2 bits	Implement Left Forward Work Light Command	2399
8.7	2 bits	Implement Rear Work Light Command	2405

The lighting command message has been defined as a global message from the tractor to all lighting controllers on the tractor and attached implements. Separate messages are provided for tractor and implement work and driving lights. Additional commands have been provided for 3 optional lights on implements to meet the needs of speciality equipment. Common marking and signaling messages are provided. This message is used to control the state of all lighting functions. The lighting command message shall be sent on each change of state of a lamp. The state values indicate the lights is to be turned ON or OFF. Flashing is accomplished by sending the lighting message with the state alternately ON or OFF. A lighting command message must be sent at least once per second. It is the responsibility of the tractor designer to provide the correct combination of lamp commands to meet local legislative directives. See PGN 65088 for the message to provide feedback for this command message.

pgn65099 - Transmission Configuration 2 - TCFG2 -

Transmission Repetition Rate: On request or sender may transmit every 5 seconds until acknowledged by reception of the engine configuration message
65251 SPN 1846.

Data Length: Variable bytes

Data Page:	0		
PDU Format:	254		
PDU Specific:	75		
Default Priority:	6		
Parameter Group Number:	65099 (00FE4B ₁₆)		
Bit Start Position /Bytes	Length	SPN Description	SPN
1-2	2 bytes	Transmission Torque Limit	1845

Contains transmission configuration information.

pgn65100 - Military Lighting Command - ML -

Transmission Repetition Rate:	500ms or upon state change, but not faster than 100 ms.		
Data Length:	8 bytes		
Data Page:	0		
PDU Format:	254		
PDU Specific:	76		
Default Priority:	6		
Parameter Group Number:	65100 (00FE4C ₁₆)		
Bit Start Position /Bytes	Length	SPN Description	SPN
1.1	2 bits	Rear Black Out Marker Select	1840
1.3	2 bits	Front Black Out Marker Lamp Select	1839
1.5	2 bits	Convoy Lamp Select	1838
1.7	2 bits	Convoy Driving Lamp Select	1837
3.7	2 bits	Black Out Brake/Stop Lamp Select	1841
4.1	2 bits	Night Vision Illuminator Select	1843
4.7	2 bits	Black Out Work Lamp Select	1842
8	1 byte	Operators Black Out Intensity Selection	1844

The message contains parameters that control military specific lights.

pgn65101 - Total Averaged Information - TAVG -

Transmission Repetition Rate:	On request		
Data Length:	8 bytes		
Data Page:	0		
PDU Format:	254		
PDU Specific:	77		
Default Priority:	7		
Parameter Group Number:	65101 (00FE4D ₁₆)		
Bit Start Position /Bytes	Length	SPN Description	SPN
1-2	2 bytes	Total Average Fuel Rate	1834
3-4	2 bytes	Total Average Fuel Economy	1835

Averages of information accumulated over the life of the engine

pgn65102 - Door Control - DC -

Transmission Repetition Rate:	100 ms		
Data Length:	8 bytes		
Data Page:	0		

PDU Format:	254		
PDU Specific:	78		
Default Priority:	6		
Parameter Group Number:	65102 (00FE4E ₁₆)		
Bit Start Position /Bytes	Length	SPN Description	SPN
1.1	4 bits	Position of doors	1821
1.5	2 bits	Ramp / Wheel Chair Lift Position	1820

Used for door information.

pgn65103 - Vehicle Dynamic Stability Control 1 - VDC1 -

Transmission Repetition Rate:	100ms		
Data Length:	8 bytes		
Data Page:	0		
PDU Format:	254		
PDU Specific:	79		
Default Priority:	6		
Parameter Group Number:	65103 (00FE4F ₁₆)		
Bit Start Position /Bytes	Length	SPN Description	SPN
1.1	2 bits	VDC Information Signal	1813
1.3	2 bits	VDC Fully Operational	1814
1.5	2 bits	VDC brake light request	1815
2.1	2 bits	ROP Engine Control active	1816
2.3	2 bits	ROP Brake Control active	1818
2.5	2 bits	YC Engine Control active	1817
2.7	2 bits	YC Brake Control active	1819

Contains information which relates to the VDC system status.

pgn65104 - Battery Temperature - BT1 -

Transmission Repetition Rate:	1 s		
Data Length:	8 bytes		
Data Page:	0		
PDU Format:	254		
PDU Specific:	80		
Default Priority:	6		
Parameter Group Number:	65104 (00FE50 ₁₆)		
Bit Start Position /Bytes	Length	SPN Description	SPN
1	1 byte	Battery 1 Temperature	1800
2	1 byte	Battery 2 Temperature	1801

Contains battery temperature information.

pgn65105 - Adaptive Cruise Control, Operator Input - ACC2 -

Transmission Repetition Rate:	250 ms		
Data Length:	8 bytes		
Data Page:	0		
PDU Format:	254		

PDU Specific:	81		
Default Priority:	6		
Parameter Group Number:	65105 (00FE51 ₁₆)		
Bit Start Position /Bytes	Length	SPN Description	SPN
1-6	3 bits	Requested ACC Distance Mode	1799

The operator requested characteristics for the ACC systems operation.

pgn65106 - Vehicle Electrical Power 3 - VP3 -

Transmission Repetition Rate:	1 s		
Data Length:	8 bytes		
Data Page:	0		
PDU Format:	254		
PDU Specific:	82		
Default Priority:	6		
Parameter Group Number:	65106 (00FE52 ₁₆)		
Bit Start Position /Bytes	Length	SPN Description	SPN
1-2	2 bytes	Alternator Current (High Range/Resolution)	1795
3-4	2 bytes	Net Battery Current (High Range/Resolution)	2579

This contains high resolution/range parameters reported from the alternator or power generation components.

pgn65107 - Retarder Continuous Torque & Speed Limit - RTC1 -

Transmission Repetition Rate:	5 s		
Data Length:	8 bytes		
Data Page:	0		
PDU Format:	254		
PDU Specific:	83		
Default Priority:	6		
Parameter Group Number:	65107 (00FE53 ₁₆)		
Bit Start Position /Bytes	Length	SPN Description	SPN
1	1 byte	Low Limit Threshold for Maximum RPM from Retarder	1776
2	1 byte	High Limit Threshold for Minimum Continuous RPM from Retarder	1777
3	1 byte	Low Limit Threshold for Maximum Torque from Retarder	1778
4	1 byte	High Limit Threshold for Minimum Continuous Torque from Retarder	1779
5	1 byte	Maximum Continuous Retarder Speed	1780
6	1 byte	Minimum Continuous Retarder Speed	1781
7	1 byte	Maximum Continuous Retarder Torque	1782
8	1 byte	Minimum Continuous Retarder Torque	1783

pgn65108 - Engine Continuous Torque & Speed Limit - ECT1 -

Transmission Repetition Rate:	5 s		
Data Length:	8 bytes		
Data Page:	0		
PDU Format:	254		
PDU Specific:	84		
Default Priority:	6		

Parameter Group Number:	65108 (00FE54 ₁₆)		
Bit Start Position /Bytes	Length	SPN Description	SPN
1	1 byte	Low Limit Threshold for Maximum RPM from Engine	1768
2	1 byte	High Limit Threshold for Minimum Continuous Engine RPM	1769
3	1 byte	Low Limit Threshold for Maximum Torque from Engine	1770
4	1 byte	High Limit Threshold for Minimum Continuous Torque from Engine	1771
5	1 byte	Maximum Continuous Engine RPM	1772
6	1 byte	Minimum Continuous Engine RPM	1773
7	1 byte	Maximum Continuous Engine Torque	1774
8	1 byte	Minimum Continuous Engine Torque	1775

pgn65109 - Gaseous Fuel Properties - GFD -

Transmission Repetition Rate:	On request		
Data Length:	8 bytes		
Data Page:	0		
PDU Format:	254		
PDU Specific:	85		
Default Priority:	6		
Parameter Group Number:	65109 (00FE55 ₁₆)		
Bit Start Position /Bytes	Length	SPN Description	SPN
1-2	2 bytes	Specific Heat Ratio	1767

pgn65110 - TANK Information 1 - TII -

Transmission Repetition Rate:	1 s		
Data Length:	8 bytes		
Data Page:	0		
PDU Format:	254		
PDU Specific:	86		
Default Priority:	6		
Parameter Group Number:	65110 (00FE56 ₁₆)		
Bit Start Position /Bytes	Length	SPN Description	SPN
1	1 byte	Catalyst Tank Level	1761

Contains information on various tank levels

pgn65111 - Air Suspension Control 5 - ASC5 -

Transmission Repetition Rate:	100 ms		
Data Length:	8 bytes		
Data Page:	0		
PDU Format:	254		
PDU Specific:	87		
Default Priority:	3		
Parameter Group Number:	65111 (00FE57 ₁₆)		
Bit Start Position /Bytes	Length	SPN Description	SPN
1	1 byte	Damper Stiffness Front Axle	1729
2	1 byte	Damper Stiffness Rear Axle	1730

3	1 byte	Damper Stiffness Lift / Tag Axle	1731
4.1	2 bits	Electronic Shock Absorber Control Mode - Front Axle	1833
4.3	2 bits	Electronic Shock Absorber Control Mode - Rear Axle	1832
4.5	2 bits	Electronic Shock Absorber Control Mode - Lift/Tag Axle	1831

Used for damper stiffness information

pgn65112 - Air Suspension Control 4 - ASC4 -

Transmission Repetition Rate:	100 ms		
Data Length:	8 bytes		
Data Page:	0		
PDU Format:	254		
PDU Specific:	88		
Default Priority:	6		
Parameter Group Number:	65112 (00FE58 ₁₆)		
Bit Start Position /Bytes	Length	SPN Description	SPN
1-2	2 bytes	Bellow Pressure Front Axle Left	1725
3-4	2 bytes	Bellow Pressure Front Axle Right	1726
5-6	2 bytes	Bellow Pressure Rear Axle Left	1727
7-8	2 bytes	Bellow Pressure Rear Axle Right	1728

Used for bellow pressure information

pgn65113 - Air Suspension Control 3 - ASC3 -

Transmission Repetition Rate:	100 ms		
Data Length:	8 bytes		
Data Page:	0		
PDU Format:	254		
PDU Specific:	89		
Default Priority:	6		
Parameter Group Number:	65113 (00FE59 ₁₆)		
Bit Start Position /Bytes	Length	SPN Description	SPN
1-2	2 bytes	Relative Level Front Axle Left	1721
3-4	2 bytes	Relative Level Front Axle Right	1722
5-6	2 bytes	Relative Level Rear Axle Left	1724
7-8	2 bytes	Relative Level Rear Axle Right	1723

Used for height information

pgn65114 - Air Suspension Control 1 - ASC1 -

Transmission Repetition Rate:	100 ms		
Data Length:	8 bytes		
Data Page:	0		
PDU Format:	254		
PDU Specific:	90		
Default Priority:	3		
Parameter Group Number:	65114 (00FE5A ₁₆)		
Bit Start Position /Bytes	Length	SPN Description	SPN

1.1	4 bits	Nominal Level Front Axle	1734
1.5	4 bits	Nominal Level Rear Axle	1733
2.1	2 bits	Below Nominal Level Front Axle	1738
2.3	2 bits	Below Nominal Level Rear Axle	1754
2.5	2 bits	Above Nominal Level Front Axle	1737
2.7	2 bits	Above Nominal Level Rear Axle	1736
3.1	2 bits	Lowering Control Mode Front Axle	1740
3.3	2 bits	Lowering Control Mode Rear Axle	1755
3.5	2 bits	Lifting Control Mode Front Axle	1739
3.7	2 bits	Lifting Control Mode Rear Axle	1756
4.1	4 bits	Kneeling Information	1742
4.5	4 bits	Level Control Mode	1741
5.1	2 bits	Security Device	1746
5.3	2 bits	Vehicle Motion Inhibit	1745
5.5	2 bits	Door Release	1744
5.7	2 bits	Lift Axle 1 Position	1743
6.1	2 bits	Front Axle in Bumper Range	1824
6.3	2 bits	Rear Axle in Bumper Range	1823
6.7	2 bits	Lift Axle 2 Position	1822
7.1	2 bits	Suspension Remote Control 1	1826
7.3	2 bits	Suspension Remote control 2	1825
8.1	4 bits	Suspension Control Refusal Information	1827

Used for suspension control control information

pgn65115 - Forward Lane Image - FLI2 -

Transmission Repetition Rate:	100 ms		
Data Length:	8 bytes		
Data Page:	0		
PDU Format:	254		
PDU Specific:	91		
Default Priority:	6		
Parameter Group Number:	65115 (00FE5B ₁₆)		
Bit Start Position /Bytes	Length	SPN Description	SPN
1.3	2 bits	Lane Tracking Status Right Side	1711
1.5	2 bits	Lane Tracking Status Left Side	1710
1.7	2 bits	Lane Departure Indication Enable Status	1702

pgn65126 - Battery Main Switch Information - BM -

Transmission Repetition Rate:	1 s		
Data Length:	8 bytes		
Data Page:	0		
PDU Format:	254		
PDU Specific:	102		
Default Priority:	6		
Parameter Group Number:	65126 (00FE66 ₁₆)		

Bit Start Position /Bytes	Length	SPN Description	SPN
1.1	2 bits	Battery Main Switch Hold State	1681

pgn65127 - Climate Control Configuration - CCC -

Transmission Repetition Rate:	On request		
Data Length:	8 bytes		
Data Page:	0		
PDU Format:	254		
PDU Specific:	103		
Default Priority:	6		
Parameter Group Number:	65127 (00FE67 ₁₆)		
Bit Start Position /Bytes	Length	SPN Description	SPN
1-2	2 bytes	Auxiliary Heater Maximum Output Power	1690

pgn65128 - Vehicle Fluids - VF -

Transmission Repetition Rate:	1 s		
Data Length:	8 bytes		
Data Page:	0		
PDU Format:	254		
PDU Specific:	104		
Default Priority:	6		
Parameter Group Number:	65128 (00FE68 ₁₆)		
Bit Start Position /Bytes	Length	SPN Description	SPN
1	1 byte	Hydraulic Temperature	1638
2.1	2 bits	Hydraulic Oil Filter Restriction Switch	1713
2.3	2 bits	Winch Oil Pressure Switch	1857
3	1 byte	Hydraulic Oil Level	2602

This parameter group transfers vehicle fluid information.

pgn65129 - Engine Temperature 3 - ET3 -

Transmission Repetition Rate:	1 s		
Data Length:	8 bytes		
Data Page:	0		
PDU Format:	254		
PDU Specific:	105		
Default Priority:	6		
Parameter Group Number:	65129 (00FE69 ₁₆)		
Bit Start Position /Bytes	Length	SPN Description	SPN
1-2	2 bytes	Intake Manifold 1 Air Temperature (High Resolution)	1636
3-4	2 bytes	Engine Coolant Temperature (High Resolution)	1637

This parameter group is used to transit high resolution engine temperatures for control purposes.

pgn65130 - Engine Fuel/lube systems - EFS -

Transmission Repetition Rate:	0.5 s		
-------------------------------	-------	--	--

Data Length:	8 bytes		
Data Page:	0		
PDU Format:	254		
PDU Specific:	106		
Default Priority:	6		
Parameter Group Number:	65130 (00FE6A ₁₆)		
Bit Start Position /Bytes	Length	SPN Description	SPN
1	1 byte	Engine Oil Level Remote Reservoir	1380
2	1 byte	Fuel Supply Pump Inlet Pressure	1381
3	1 byte	Fuel Filter (suction side) Differential Pressure	1382

pgn65131 - Driver's Identification - DI -

Transmission Repetition Rate:	On request		
Data Length:	Variable bytes		
Data Page:	0		
PDU Format:	254		
PDU Specific:	107		
Default Priority:	6		
Parameter Group Number:	65131 (00FE6B ₁₆)		
Bit Start Position /Bytes	Length	SPN Description	SPN
1-2	Variable ("*" delimited)	Driver 1 identification	1625
3-4	Variable ("*" delimited)	Driver 2 identification	1626

Field: a Driver 1 Identification Delimiter (ASCII '*') b Driver 2 Identification Delimiter (ASCII '*') NOTE - If only driver card 1 is present, only the parameter driver 1 identification and two delimiters shall be transmitted. If only driver card 2 is present, a delimiter followed by parameter driver 2 identification and the second delimiter shall be transmitted. If no driver cards are present, only the two delimiters shall be sent."

pgn65132 - Tachograph - TCO1 -

Transmission Repetition Rate:	50 ms		
Data Length:	8 bytes		
Data Page:	0		
PDU Format:	254		
PDU Specific:	108		
Default Priority:	3		
Parameter Group Number:	65132 (00FE6C ₁₆)		
Bit Start Position /Bytes	Length	SPN Description	SPN
1.1	3 bits	Driver 1 working state	1612
1.4	3 bits	Driver 2 working state	1613
1.7	2 bits	Drive recognize	1611
2.1	4 bits	Driver 1 Time Related States	1617
2.5	2 bits	Driver card, driver 1	1615
2.7	2 bits	Overspeed	1614
3.1	4 bits	Driver 2 Time Related States	1618

3.5	2 bits	Driver card, driver 2	1616
4.1	2 bits	System event	1622
4.3	2 bits	Handling information	1621
4.5	2 bits	Tachograph performance	1620
4.7	2 bits	Direction indicator	1619
5-6	2 bytes	Tachograph output shaft speed	1623
7-8	2 bytes	Tachograph vehicle speed	1624

pgn65133 - Heater Information - HTR -

Transmission Repetition Rate:		1 s	
Data Length:		8 bytes	
Data Page:		0	
PDU Format:		254	
PDU Specific:		109	
Default Priority:		6	
Parameter Group Number:		65133 (00FE6D ₁₆)	
Bit Start Position /Bytes	Length	SPN Description	SPN
1	1 byte	Auxiliary Heater Output Coolant Temperature	1687
2	1 byte	Auxiliary Heater Input Air Temperature	1688
3	1 byte	Auxiliary Heater Output Power Percent	1689
4.1	4 bits	Auxiliary Heater Mode	1677
5.1	2 bits	Auxiliary Heater Water Pump Status	1676
5.3	2 bits	Cab Ventilation	1678
5.5	2 bits	Engine Heating Zone	1679
5.7	2 bits	Cab Heating Zone	1680

pgn65134 - High Resolution Wheel Speed - HRW -

Transmission Repetition Rate:		20 ms	
Data Length:		8 bytes	
Data Page:		0	
PDU Format:		254	
PDU Specific:		110	
Default Priority:		2	
Parameter Group Number:		65134 (00FE6E ₁₆)	
Bit Start Position /Bytes	Length	SPN Description	SPN
1-2	2 bytes	Front Axle, Left Wheel Speed	1592
3-4	2 bytes	Front axle, right wheel speed	1593
5-6	2 bytes	Rear axle, left wheel speed	1594
7-8	2 bytes	Rear axle, right wheel speed	1595

pgn65135 - Adaptive Cruise Control - ACC1 -

Transmission Repetition Rate:		100 ms
Data Length:		8 bytes
Data Page:		0
PDU Format:		254

PDU Specific:		111	
Default Priority:		4	
Parameter Group Number:		65135 (00FE6F ₁₆)	
Bit Start Position /Bytes	Length	SPN Description	SPN
1	1 byte	Speed of forward vehicle	1586
2	1 byte	Distance to forward vehicle	1587
3	1 byte	Adaptive Cruise Control Set Speed	1588
4.1	3 bits	Adaptive Cruise Control Mode	1590
4.4	3 bits	Adaptive cruise control set distance mode	1589
5-6	2 bytes	Road curvature	1591
7.1	2 bits	ACC Target Detected	1798
7.3	2 bits	ACC System Shutoff Warning	1797
7.5	2 bits	ACC Distance Alert Signal	1796

NOTE- The ACC1 message is required whenever the engine is running and ACC is powered on and not faulted. The timeout for ACC1 message will be between 2.5 times to 5 times the update rate. The ACC1 message is intended primarily for engines and driver display units. The receiving device should identify the ACC device based on ACC function value of 32 (headway controller) or source address of 42 (headway controller). In the event that the engine is running, the ACC is installed and the ACC1 message is not present, the engine will disable cruise control and return to non-cruise mode; also, the driver display unit will notify the driver that ACC operation is no longer available. In addition to the ACC1 timeout, engine cruise control will also be disabled if parameter ""Adaptive Cruise Control State"" in ACC1 is 110b (ACC disabled or in error). In some cases, it may be possible for the driver to restart cruise control (without ACC capability) during ACC/J1939 fault by performing a reset function. See Figure PGN65135_A. It is possible that engines and driver display units may require calibration settings in order to know if the present vehicle configuration includes an ACC system or not. A calibration setting may also be needed for defining the driver reset function.

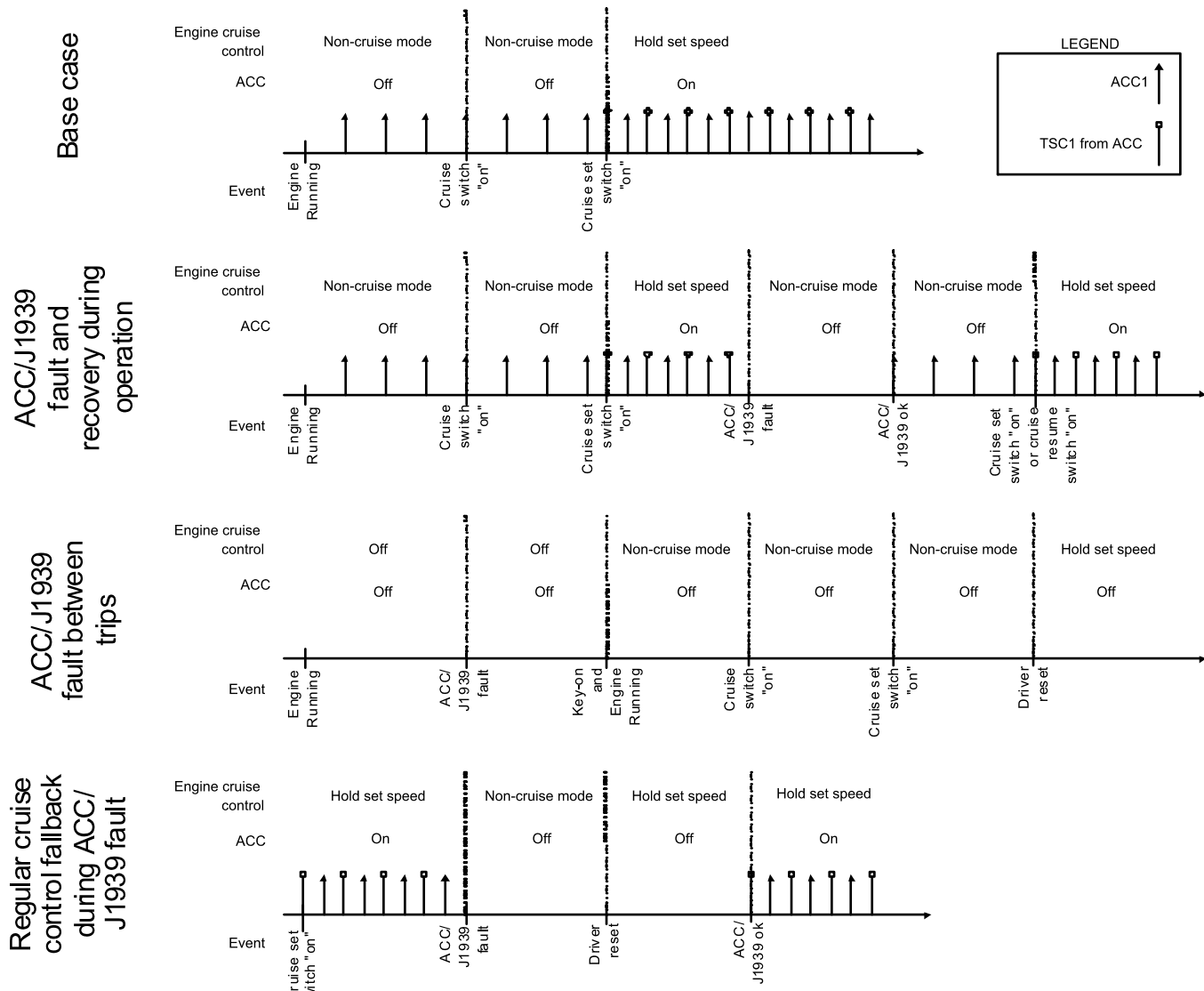

FIGURE PGN65135_A -- ADAPTIVE CRUISE CONTROL TIMING DIAGRAM

pgn65136 - Combination Vehicle Weight - CVW -

Transmission Repetition Rate:	On request		
Data Length:	Variable bytes		
Data Page:	0		
PDU Format:	254		
PDU Specific:	112		
Default Priority:	6		
Parameter Group Number:	65136 (00FE70 ₁₆)		
Bit Start Position /Bytes	Length	SPN Description	SPN
1-2	2 bytes	Powered Vehicle Weight	1585
3-4	2 bytes	Gross Combination Vehicle Weight	1760

pgn65137 - Laser Tracer Position - LTP -

Transmission Repetition Rate:	50 ms		
Data Length:	8 bytes		
Data Page:	0		
PDU Format:	254		
PDU Specific:	113		
Default Priority:	3		
Parameter Group Number:	65137 (00FE71 ₁₆)		
Bit Start Position /Bytes	Length	SPN Description	SPN
1-2	2 bytes	Laser Tracer Target Deviation	1579
3-4	2 bytes	Laser Tracer Vertical Distance	1580
5	1 byte	Laser Tracer Horizontal Deviation	1581
6	8 bits	LED Display Data #2	1582
7	8 bits	Laser Tracer Information	1583

pgn65138 - Laser Leveling System Blade Control - LBC -

Transmission Repetition Rate:	50 ms		
Data Length:	8 bytes		
Data Page:	0		
PDU Format:	254		
PDU Specific:	114		
Default Priority:	3		
Parameter Group Number:	65138 (00FE72 ₁₆)		
Bit Start Position /Bytes	Length	SPN Description	SPN
1-2	2 bytes	Blade Duration and Direction	1577
3	8 bits	Blade Control Mode	1578

pgn65139 - Laser Receiver Mast Position - LMP -

Transmission Repetition Rate:	50 ms		
Data Length:	8 bytes		
Data Page:	0		
PDU Format:	254		
PDU Specific:	115		
Default Priority:	3		
Parameter Group Number:	65139 (00FE73 ₁₆)		
Bit Start Position /Bytes	Length	SPN Description	SPN
1-2	2 bytes	Mast Position	1576

pgn65140 - Modify Leveling System Control Set Point - LSP -

Transmission Repetition Rate:	50 ms		
Data Length:	8 bytes		
Data Page:	0		
PDU Format:	254		
PDU Specific:	116		
Default Priority:	3		
Parameter Group Number:	65140 (00FE74 ₁₆)		

Bit Start Position /Bytes	Length	SPN Description	SPN
1-2	2 bytes	Modify Set Point	1575
3-6	4 bytes	Blade Height Set Point - High Resolution	1759

pgn65141 - Laser Leveling System Vertical Deviation - LVD -

Transmission Repetition Rate:	50 ms		
Data Length:	8 bytes		
Data Page:	0		
PDU Format:	254		
PDU Specific:	117		
Default Priority:	3		
Parameter Group Number:	65141 (00FE75 ₁₆)		
Bit Start Position /Bytes	Length	SPN Description	SPN
1-2	2 bytes	Laser Strike Vertical Deviation	1574
3	1 byte	Laser Receiver Type	2576
4-5	2 bytes	Laser Strike Data Latency	2793
6-7	2 bytes	Absolute Laser Strike Position	2794

pgn65142 - Laser Leveling System Vertical Position Display Data - LVDD -

Transmission Repetition Rate:	100 ms		
Data Length:	8 bytes		
Data Page:	0		
PDU Format:	254		
PDU Specific:	118		
Default Priority:	4		
Parameter Group Number:	65142 (00FE76 ₁₆)		
Bit Start Position /Bytes	Length	SPN Description	SPN
1	8 bits	LED Display Data #1	1573
2.1	4 bits	LED Display Mode Control	1805
2.5	4 bits	LED Display Deadband Control	1806
3.1	4 bits	LED Pattern Control	2578
3.5	4 bits	Display Deadbands	2577

pgn65143 - Auxiliary Pressures - AP -

Transmission Repetition Rate:	On request		
Data Length:	8 bytes		
Data Page:	0		
PDU Format:	254		
PDU Specific:	119		
Default Priority:	7		
Parameter Group Number:	65143 (00FE77 ₁₆)		
Bit Start Position /Bytes	Length	SPN Description	SPN
1-2	2 bytes	Auxiliary Vacuum Pressure Reading	136
3-4	2 bytes	Auxiliary Gage Pressure Reading 1	137
5-6	2 bytes	Auxiliary Absolute Pressure Reading	138

pgn65144 - Tire Pressure Control Unit Mode and Status - TP1 -

Transmission Repetition Rate:	On request		
Data Length:	8 bytes		
Data Page:	0		
PDU Format:	254		
PDU Specific:	120		
Default Priority:	7		
Parameter Group Number:	65144 (00FE78 ₁₆)		
Bit Start Position /Bytes	Length	SPN Description	SPN
1	1 byte	Tire Pressure Check Interval	39
2.1	4 bits	Steer Channel Mode	1466
3.1	4 bits	Trailer/tag Channel Mode	1467
3.5	4 bits	Drive Channel Mode	1468
4.1	2 bits	PCU Drive Solenoid Status	1469
4.3	2 bits	PCU Steer Solenoid Status	1470
4.5	2 bits	Tire Pressure Supply Switch Status	1471
5.1	2 bits	PCU Deflate Solenoid Status	1472
5.3	2 bits	PCU Control Solenoid Status	1473
5.5	2 bits	PCU Supply Solenoid Status	1474
5.7	2 bits	PCU Trailer, Tag or Push Solenoid Status	1475

pgn65145 - Tire Pressure Control Unit Target Pressures - TP2 -

Transmission Repetition Rate:	On request		
Data Length:	8 bytes		
Data Page:	0		
PDU Format:	254		
PDU Specific:	121		
Default Priority:	7		
Parameter Group Number:	65145 (00FE79 ₁₆)		
Bit Start Position /Bytes	Length	SPN Description	SPN
1-2	2 bytes	Trailer, Tag Or Push Channel Tire Pressure Target	141
3-4	2 bytes	Drive Channel Tire Pressure Target	142
5-6	2 bytes	Steer Channel Tire Pressure Target	143

pgn65146 - Tire Pressure Control Unit Current Pressures - TP3 -

Transmission Repetition Rate:	On request		
Data Length:	8 bytes		
Data Page:	0		
PDU Format:	254		
PDU Specific:	122		
Default Priority:	7		
Parameter Group Number:	65146 (00FE7A ₁₆)		
Bit Start Position /Bytes	Length	SPN Description	SPN
1-2	2 bytes	Trailer, Tag Or Push Channel Tire Pressure	144

3-4	2 bytes	Drive Channel Tire Pressure	145
5-6	2 bytes	Steel Channel Tire Pressure	146

pgn65147 - Combustion Time 1 - CT1 -

Transmission Repetition Rate:	On request		
Data Length:	8 bytes		
Data Page:	0		
PDU Format:	254		
PDU Specific:	123		
Default Priority:	7		
Parameter Group Number:	65147 (00FE7B ₁₆)		
Bit Start Position /Bytes	Length	SPN Description	SPN
1-2	2 bytes	Cylinder 1 Combustion Time	1444
3-4	2 bytes	Cylinder 2 Combustion Time	1445
5-6	2 bytes	Cylinder 3 Combustion Time	1446
7-8	2 bytes	Cylinder 4 Combustion Time	1447

pgn65148 - Combustion Time 2 - CT2 -

Transmission Repetition Rate:	On request		
Data Length:	8 bytes		
Data Page:	0		
PDU Format:	254		
PDU Specific:	124		
Default Priority:	7		
Parameter Group Number:	65148 (00FE7C ₁₆)		
Bit Start Position /Bytes	Length	SPN Description	SPN
1-2	2 bytes	Cylinder 5 Combustion Time	1448
3-4	2 bytes	Cylinder 6 Combustion Time	1449
5-6	2 bytes	Cylinder 7 Combustion Time	1450
7-8	2 bytes	Cylinder 8 Combustion Time	1451

pgn65149 - Combustion Time 3 - CT3 -

Transmission Repetition Rate:	On request		
Data Length:	8 bytes		
Data Page:	0		
PDU Format:	254		
PDU Specific:	125		
Default Priority:	7		
Parameter Group Number:	65149 (00FE7D ₁₆)		
Bit Start Position /Bytes	Length	SPN Description	SPN
1-2	2 bytes	Cylinder 9 Combustion Time	1452
3-4	2 bytes	Cylinder 10 Combustion Time	1453
5-6	2 bytes	Cylinder 11 Combustion Time	1454
7-8	2 bytes	Cylinder 12 Combustion Time	1455

pgn65150 - Combustion Time 4 - CT4 -

Transmission Repetition Rate:	On request		
Data Length:	8 bytes		
Data Page:	0		
PDU Format:	254		
PDU Specific:	126		
Default Priority:	7		
Parameter Group Number:	65150 (00FE7E ₁₆)		
Bit Start Position /Bytes	Length	SPN Description	SPN
1-2	2 bytes	Cylinder 13 Combustion Time	1456
3-4	2 bytes	Cylinder 14 Combustion Time	1457
5-6	2 bytes	Cylinder 15 Combustion Time	1458
7-8	2 bytes	Cylinder 16 Combustion Time	1459

pgn65151 - Combustion Time 5 - CT5 -

Transmission Repetition Rate:	On request		
Data Length:	8 bytes		
Data Page:	0		
PDU Format:	254		
PDU Specific:	127		
Default Priority:	7		
Parameter Group Number:	65151 (00FE7F ₁₆)		
Bit Start Position /Bytes	Length	SPN Description	SPN
1-2	2 bytes	Cylinder 17 Combustion Time	1460
3-4	2 bytes	Cylinder 18 Combustion Time	1461
5-6	2 bytes	Cylinder 19 Combustion Time	1462
7-8	2 bytes	Cylinder 20 Combustion Time	1463

pgn65152 - Combustion Time 6 - CT6 -

Transmission Repetition Rate:	On request		
Data Length:	8 bytes		
Data Page:	0		
PDU Format:	254		
PDU Specific:	128		
Default Priority:	7		
Parameter Group Number:	65152 (00FE80 ₁₆)		
Bit Start Position /Bytes	Length	SPN Description	SPN
1-2	2 bytes	Desired Combustion Time	1464
3-4	2 bytes	Average Engine Combustion Time	1465

pgn65153 - Fuel Information 2 (Gaseous) - GF12 -

Transmission Repetition Rate:	On request
Data Length:	8 bytes
Data Page:	0

PDU Format:	254		
PDU Specific:	129		
Default Priority:	7		
Parameter Group Number:	65153 (00FE81 ₁₆)		
Bit Start Position /Bytes	Length	SPN Description	SPN
1-2	2 bytes	Fuel Flow Rate 1	1440
3-4	2 bytes	Fuel Flow Rate 2	1441
5	1 byte	Fuel Valve 1 Position	1442
6	1 byte	Fuel Valve 2 Position	1443
7	1 byte	Requested Fuel Valve 1 Position	1765
8	1 byte	Requested Fuel Valve 2 Position	1766

pgn65154 - Ignition Timing 1 - IT1 -

Transmission Repetition Rate:	On request		
Data Length:	8 bytes		
Data Page:	0		
PDU Format:	254		
PDU Specific:	130		
Default Priority:	7		
Parameter Group Number:	65154 (00FE82 ₁₆)		
Bit Start Position /Bytes	Length	SPN Description	SPN
1-2	2 bytes	Cylinder 1 Ignition Timing	1413
3-4	2 bytes	Cylinder 2 Ignition Timing	1414
5-6	2 bytes	Cylinder 3 Ignition Timing	1415
7-8	2 bytes	Cylinder 4 Ignition Timing	1416

pgn65155 - Ignition Timing 2 - IT2 -

Transmission Repetition Rate:	On request		
Data Length:	8 bytes		
Data Page:	0		
PDU Format:	254		
PDU Specific:	131		
Default Priority:	7		
Parameter Group Number:	65155 (00FE83 ₁₆)		
Bit Start Position /Bytes	Length	SPN Description	SPN
1-2	2 bytes	Cylinder 5 Ignition Timing	1417
3-4	2 bytes	Cylinder 6 Ignition Timing	1418
5-6	2 bytes	Cylinder 7 Ignition Timing	1419
7-8	2 bytes	Cylinder 8 Ignition Timing	1420

pgn65156 - Ignition Timing 3 - IT3 -

Transmission Repetition Rate:	On request
Data Length:	8 bytes
Data Page:	0
PDU Format:	254

PDU Specific:		132	
Default Priority:		7	
Parameter Group Number:		65156 (00FE84 ₁₆)	
Bit Start Position /Bytes	Length	SPN Description	SPN
1-2	2 bytes	Cylinder 9 Ignition Timing	1421
3-4	2 bytes	Cylinder 10 Ignition Timing	1422
5-6	2 bytes	Cylinder 11 Ignition Timing	1423
7-8	2 bytes	Cylinder 12 Ignition Timing	1424

pgn65157 - Ignition Timing 4 - IT4 -

Transmission Repetition Rate:		On request	
Data Length:		8 bytes	
Data Page:		0	
PDU Format:		254	
PDU Specific:		133	
Default Priority:		7	
Parameter Group Number:		65157 (00FE85 ₁₆)	
Bit Start Position /Bytes	Length	SPN Description	SPN
1-2	2 bytes	Cylinder 13 Ignition Timing	1425
3-4	2 bytes	Cylinder 14 Ignition Timing	1426
5-6	2 bytes	Cylinder 15 Ignition Timing	1427
7-8	2 bytes	Cylinder 16 Ignition Timing	1428

pgn65158 - Ignition Timing 5 - IT5 -

Transmission Repetition Rate:		On request	
Data Length:		8 bytes	
Data Page:		0	
PDU Format:		254	
PDU Specific:		134	
Default Priority:		7	
Parameter Group Number:		65158 (00FE86 ₁₆)	
Bit Start Position /Bytes	Length	SPN Description	SPN
1-2	2 bytes	Cylinder 17 Ignition Timing	1429
3-4	2 bytes	Cylinder 18 Ignition Timing	1430
5-6	2 bytes	Cylinder 19 Ignition Timing	1431
7-8	2 bytes	Cylinder 20 Ignition Timing	1432

pgn65159 - Ignition Timing 6 - IT6 -

Transmission Repetition Rate:		On request	
Data Length:		8 bytes	
Data Page:		0	
PDU Format:		254	
PDU Specific:		135	
Default Priority:		7	
Parameter Group Number:		65159 (00FE87 ₁₆)	

Bit Start Position /Bytes	Length	SPN Description	SPN
1-2	2 bytes	Desired Ignition Timing #1	1433
3-4	2 bytes	Desired Ignition Timing #2	1434
5-6	2 bytes	Desired Ignition Timing #3	1435
7-8	2 bytes	Actual Ignition Timing	1436

pgn65160 - Ignition Transformer Secondary Output 1 - ISO1 -

Transmission Repetition Rate: On request
 Data Length: 8 bytes
 Data Page: 0
 PDU Format: 254
 PDU Specific: 136
 Default Priority: 7
 Parameter Group Number: 65160 (00FE88₁₆)

Bit Start Position /Bytes	Length	SPN Description	SPN
1	1 byte	Cylinder 1 Ignition Transformer Secondary Output	1393
2	1 byte	Cylinder 2 Ignition Transformer Secondary Output	1394
3	1 byte	Cylinder 3 Ignition Transformer Secondary Output	1395
4	1 byte	Cylinder 4 Ignition Transformer Secondary Output	1396
5	1 byte	Cylinder 5 Ignition Transformer Secondary Output	1397
6	1 byte	Cylinder 6 Ignition Transformer Secondary Output	1398
7	1 byte	Cylinder 7 Ignition Transformer Secondary Output	1399
8	1 byte	Cylinder 8 Ignition Transformer Secondary Output	1400

pgn65161 - Ignition Transformer Secondary Output 2 - ISO2 -

Transmission Repetition Rate: On request
 Data Length: 8 bytes
 Data Page: 0
 PDU Format: 254
 PDU Specific: 137
 Default Priority: 7
 Parameter Group Number: 65161 (00FE89₁₆)

Bit Start Position /Bytes	Length	SPN Description	SPN
1	1 byte	Cylinder 9 Ignition Transformer Secondary Output	1401
2	1 byte	Cylinder 10 Ignition Transformer Secondary Output	1402
3	1 byte	Cylinder 11 Ignition Transformer Secondary Output	1403
4	1 byte	Cylinder 12 Ignition Transformer Secondary Output	1404
5	1 byte	Cylinder 13 Ignition Transformer Secondary Output	1405
6	1 byte	Cylinder 14 Ignition Transformer Secondary Output	1406
7	1 byte	Cylinder 15 Ignition Transformer Secondary Output	1407
8	1 byte	Cylinder 16 Ignition Transformer Secondary Output	1408

pgn65162 - Ignition Transformer Secondary Output 3 - ISO3 -

Transmission Repetition Rate: On request
 Data Length: 8 bytes

Data Page:	0		
PDU Format:	254		
PDU Specific:	138		
Default Priority:	7		
Parameter Group Number:	65162 (00FE8A ₁₆)		
Bit Start Position /Bytes	Length	SPN Description	SPN
1	1 byte	Cylinder 17 Ignition Transformer Secondary Output	1409
2	1 byte	Cylinder 18 Ignition Transformer Secondary Output	1410
3	1 byte	Cylinder 19 Ignition Transformer Secondary Output	1411
4	1 byte	Cylinder 20 Ignition Transformer Secondary Output	1412

pgn65163 - Gaseous Fuel Pressure - GFP -

Transmission Repetition Rate:	On request		
Data Length:	8 bytes		
Data Page:	0		
PDU Format:	254		
PDU Specific:	139		
Default Priority:	7		
Parameter Group Number:	65163 (00FE8B ₁₆)		
Bit Start Position /Bytes	Length	SPN Description	SPN
1-2	2 bytes	Absolute Fuel Valve Inlet Pressure	1390
3-4	2 bytes	Outlet to Inlet Fuel Valve Differential Pressure	1391
5-6	2 bytes	Air to Fuel Differential Pressure	1392

pgn65164 - Auxiliary Analog Information - AAI -

Transmission Repetition Rate:	On request		
Data Length:	8 bytes		
Data Page:	0		
PDU Format:	254		
PDU Specific:	140		
Default Priority:	7		
Parameter Group Number:	65164 (00FE8C ₁₆)		
Bit Start Position /Bytes	Length	SPN Description	SPN
1	1 byte	Auxiliary Temperature 1	441
2	1 byte	Auxiliary Temperature 2	442
3	1 byte	Auxiliary Pressure #1	1387
4	1 byte	Auxiliary Pressure #2	1388

pgn65165 - Vehicle Electrical Power 2 - VP2 -

Transmission Repetition Rate:	On request		
Data Length:	8 bytes		
Data Page:	0		
PDU Format:	254		
PDU Specific:	141		
Default Priority:	7		

Parameter Group Number:	65165 (00FE8D ₁₆)		
Bit Start Position /Bytes	Length	SPN Description	SPN
1-2	2 bytes	Battery 2 Potential (Voltage)	444

pgn65166 - Service 2 - S2 -

Transmission Repetition Rate:	On request		
Data Length:	8 bytes		
Data Page:	0		
PDU Format:	254		
PDU Specific:	142		
Default Priority:	7		
Parameter Group Number:	65166 (00FE8E ₁₆)		
Bit Start Position /Bytes	Length	SPN Description	SPN
1	1 byte	Service Component Identification	1379
2-3	2 bytes	Time Since Last Service	1350

NOTE - There are two acceptable formats for the Service PGN. Format 1 has only 8 bytes of data and reports the component most in need of service for each of the three categories. Format 2, however, uses the transport layer as necessary in order to repeat these 8 bytes of service component information until all supported service components in each category have been transmitted.

pgn65167 - Supply Pressure 2 - SP2 -

Transmission Repetition Rate:	1 s		
Data Length:	8 bytes		
Data Page:	0		
PDU Format:	254		
PDU Specific:	143		
Default Priority:	6		
Parameter Group Number:	65167 (00FE8F ₁₆)		
Bit Start Position /Bytes	Length	SPN Description	SPN
1-2	2 bytes	Externally Supplied Air Pressure	1320

pgn65168 - Engine Torque History - ETH -

Transmission Repetition Rate:	On request		
Data Length:	Variable bytes		
Data Page:	0		
PDU Format:	254		
PDU Specific:	144		
Default Priority:	6		
Parameter Group Number:	65168 (00FE90 ₁₆)		
Bit Start Position /Bytes	Length	SPN Description	SPN
01	1 byte	Number of Torque History Records	1246
02-03	2 bytes	Engine Power	1247
04-05	2 bytes	Peak Engine Torque 1	1248
06-07	2 bytes	Peak Engine Torque 2	1249
08	1 byte	Calibration Record Start Month	1250
09	1 byte	Calibration Record Start Day	1251

10	1 byte	Calibration Record Start Year	1252
11-14	4 bytes	Calibration Record Duration Time	1253
15.1	2 bits	Torque Limiting Feature Status	1254
15.3	3 bits	Torque Limit Feature	1632
16-17	2 bytes	Transmission Gear Ratio 1	1255
18-19	2 bytes	Engine Torque Limit 1, Transmission	1256
20-21	2 bytes	Transmission Gear Ratio 2	1257
22-23	2 bytes	Engine Torque Limit 2, Transmission	1258
24-25	2 bytes	Transmission Gear Ratio 3	1259
26-27	2 bytes	Engine Torque Limit 3, Transmission	1260
28-29	2 bytes	Engine Torque Limit 4, Transmission	1261
30-31	2 bytes	Engine Torque Limit 5, Switch	1262
32-33	2 bytes	Engine Torque Limit 6, Axle Input	1263

NOTE - The torque history PGN is variable in length and may contain up to 125 torque history records. Each torque history record MUST BE 38 bytes in length. Any unused bytes must be 0xFF.

Note:

As stated earlier, each torque history record is 38 bytes in length. The last six bytes of each record are not currently defined and shall be transmitted as “not available” (0xff). In the first record, these are byte positions 34-39.

pgn65169 - Fuel Leakage - FL -

Transmission Repetition Rate:	1 s		
Data Length:	8 bytes		
Data Page:	0		
PDU Format:	254		
PDU Specific:	145		
Default Priority:	7		
Parameter Group Number:	65169 (00FE91 ₁₆)		
Bit Start Position /Bytes	Length	SPN Description	SPN
1.1	2 bits	Fuel Leakage 1	1239
1.3	2 bits	Fuel Leakage 2	1240

pgn65170 - Engine Information - EI -

Transmission Repetition Rate:	100 ms		
Data Length:	8 bytes		
Data Page:	0		
PDU Format:	254		
PDU Specific:	146		
Default Priority:	7		
Parameter Group Number:	65170 (00FE92 ₁₆)		
Bit Start Position /Bytes	Length	SPN Description	SPN
1	1 byte	Pre-filter Oil Pressure	1208

2-3	2 bytes	Exhaust Gas Pressure	1209
4	1 byte	Fuel Rack Position	1210
5-6	2 bytes	Mass Flow (Gaseous)	1241
7-8	2 bytes	Instantaneous Estimated Brake Power	1242

pgn65171 - Engine Electrical System/Module Information - EES -

Transmission Repetition Rate:		100 ms	
Data Length:		8 bytes	
Data Page:		0	
PDU Format:		254	
PDU Specific:		147	
Default Priority:		7	
Parameter Group Number:		65171 (00FE93 ₁₆)	
Bit Start Position /Bytes	Length	SPN Description	SPN
1-2	2 bytes	Electrical Load	1204
3.1	2 bits	Safety Wire Status	1205
3.3	2 bits	Turning Gear Engaged	1206

pgn65172 - Engine Auxiliary Coolant - EAC -

Transmission Repetition Rate:		0.5 s	
Data Length:		8 bytes	
Data Page:		0	
PDU Format:		254	
PDU Specific:		148	
Default Priority:		6	
Parameter Group Number:		65172 (00FE94 ₁₆)	
Bit Start Position /Bytes	Length	SPN Description	SPN
1	1 byte	Engine Auxiliary Coolant Pressure	1203
2	1 byte	Engine Auxiliary Coolant Temperature	1212
3	1 byte	Sea Water Pump Outlet Pressure	2435

pgn65173 - Rebuild Information - RBI -

Transmission Repetition Rate:		On request	
Data Length:		8 bytes	
Data Page:		0	
PDU Format:		254	
PDU Specific:		149	
Default Priority:		7	
Parameter Group Number:		65173 (00FE95 ₁₆)	
Bit Start Position /Bytes	Length	SPN Description	SPN
1-4	4 bytes	Engine Operation Time Since Rebuild	1193

pgn65174 - Turbocharger Wastegate - TCW -

Transmission Repetition Rate:		100 ms
-------------------------------	--	--------

Data Length:	8 bytes		
Data Page:	0		
PDU Format:	254		
PDU Specific:	150		
Default Priority:	6		
Parameter Group Number:	65174 (00FE96 ₁₆)		
Bit Start Position /Bytes	Length	SPN Description	SPN
1	1 byte	Turbocharger 1 Wastegate Drive	1188
2	1 byte	Turbocharger 2 Wastegate Drive	1189
3	1 byte	Turbocharger 3 Wastegate Drive	1190
4	1 byte	Turbocharger 4 Wastegate Drive	1191
5	1 byte	Turbocharger Wastegate Actuator Control Air Pressure	1192

pgn65175 - Turbocharger Information 5 - TCI5 -

Transmission Repetition Rate:	1 s		
Data Length:	8 bytes		
Data Page:	0		
PDU Format:	254		
PDU Specific:	151		
Default Priority:	6		
Parameter Group Number:	65175 (00FE97 ₁₆)		
Bit Start Position /Bytes	Length	SPN Description	SPN
1-2	2 bytes	Turbocharger 1 Turbine Outlet Temperature	1184
3-4	2 bytes	Turbocharger 2 Turbine Outlet Temperature	1185
5-6	2 bytes	Turbocharger 3 Turbine Outlet Temperature	1186
7-8	2 bytes	Turbocharger 4 Turbine Outlet Temperature	1187

pgn65176 - Turbocharger Information 4 - TCI4 -

Transmission Repetition Rate:	1 s		
Data Length:	8 bytes		
Data Page:	0		
PDU Format:	254		
PDU Specific:	152		
Default Priority:	6		
Parameter Group Number:	65176 (00FE98 ₁₆)		
Bit Start Position /Bytes	Length	SPN Description	SPN
1-2	2 bytes	Turbocharger 1 Turbine Inlet Temperature	1180
3-4	2 bytes	Turbocharger 2 Turbine Inlet Temperature	1181
5-6	2 bytes	Turbocharger 3 Turbine Inlet Temperature	1182
7-8	2 bytes	Turbocharger 4 Turbine Inlet Temperature	1183

pgn65177 - Turbocharger Information 3 - TCI3 -

Transmission Repetition Rate:	1 s
Data Length:	8 bytes
Data Page:	0

PDU Format:	254		
PDU Specific:	153		
Default Priority:	6		
Parameter Group Number:	65177 (00FE99 ₁₆)		
Bit Start Position /Bytes	Length	SPN Description	SPN
1-2	2 bytes	Turbocharger 1 Compressor Inlet Pressure	1176
3-4	2 bytes	Turbocharger 2 Compressor Inlet Pressure	1177
5-6	2 bytes	Turbocharger 3 Compressor Inlet Pressure	1178
7-8	2 bytes	Turbocharger 4 Compressor Inlet Pressure	1179

pgn65178 - Turbocharger Information 2 - TC12 -

Transmission Repetition Rate:	1 s		
Data Length:	8 bytes		
Data Page:	0		
PDU Format:	254		
PDU Specific:	154		
Default Priority:	6		
Parameter Group Number:	65178 (00FE9A ₁₆)		
Bit Start Position /Bytes	Length	SPN Description	SPN
1	2 bytes	Turbocharger 1 Compressor Inlet Temperature	1172
2	2 bytes	Turbocharger 2 Compressor Inlet Temperature	1173
3	2 bytes	Turbocharger 3 Compressor Inlet Temperature	1174
4	2 bytes	Turbocharger 4 Compressor Inlet Temperature	1175

pgn65179 - Turbocharger Information 1 - TC11 -

Transmission Repetition Rate:	1 s		
Data Length:	8 bytes		
Data Page:	0		
PDU Format:	254		
PDU Specific:	155		
Default Priority:	7		
Parameter Group Number:	65179 (00FE9B ₁₆)		
Bit Start Position /Bytes	Length	SPN Description	SPN
1	1 byte	Turbocharger Lube Oil Pressure 2	1168
2-3	2 bytes	Turbocharger 2 Speed	1169
4-5	2 bytes	Turbocharger 3 Speed	1170
6-7	2 bytes	Turbocharger 4 Speed	1171

pgn65180 - Main Bearing Temperature 3 - MBT3 -

Transmission Repetition Rate:	1 s		
Data Length:	8 bytes		
Data Page:	0		
PDU Format:	254		
PDU Specific:	156		
Default Priority:	6		

Parameter Group Number:	65180 (00FE9C ₁₆)		
Bit Start Position /Bytes	Length	SPN Description	SPN
1-2	2 bytes	Main Bearing 9 Temperature	1165
3-4	2 bytes	Main Bearing 10 Temperature	1166
5-6	2 bytes	Main Bearing 11 Temperature	1167

pgn65181 - Main Bearing Temperature 2 - MBT2 -

Transmission Repetition Rate:	1 s		
Data Length:	8 bytes		
Data Page:	0		
PDU Format:	254		
PDU Specific:	157		
Default Priority:	6		
Parameter Group Number:	65181 (00FE9D ₁₆)		
Bit Start Position /Bytes	Length	SPN Description	SPN
1-2	2 bytes	Main Bearing 5 Temperature	1161
3-4	2 bytes	Main Bearing 6 Temperature	1162
5-6	2 bytes	Main Bearing 7 Temperature	1163
7-8	2 bytes	Main Bearing 8 Temperature	1164

pgn65182 - Main Bearing Temperature 1 - MBT1 -

Transmission Repetition Rate:	1 s		
Data Length:	8 bytes		
Data Page:	0		
PDU Format:	254		
PDU Specific:	158		
Default Priority:	6		
Parameter Group Number:	65182 (00FE9E ₁₆)		
Bit Start Position /Bytes	Length	SPN Description	SPN
1-2	2 bytes	Main Bearing 1 Temperature	1157
3-4	2 bytes	Main Bearing 2 Temperature	1158
5-6	2 bytes	Main Bearing 3 Temperature	1159
7-8	2 bytes	Main Bearing 4 Temperature	1160

pgn65183 - Exhaust Port Temperature 5 - EPT5 -

Transmission Repetition Rate:	1 s		
Data Length:	8 bytes		
Data Page:	0		
PDU Format:	254		
PDU Specific:	159		
Default Priority:	7		
Parameter Group Number:	65183 (00FE9F ₁₆)		
Bit Start Position /Bytes	Length	SPN Description	SPN
1-2	2 bytes	Exhaust Gas Port 17 Temperature	1153
3-4	2 bytes	Exhaust Gas Port 18 Temperature	1154

5-6	2 bytes	Exhaust Gas Port 19 Temperature	1155
7-8	2 bytes	Exhaust Gas Port 20 Temperature	1156

pgn65184 - Exhaust Port Temperature 4 - EPT4 -

Transmission Repetition Rate:	1 s		
Data Length:	8 bytes		
Data Page:	0		
PDU Format:	254		
PDU Specific:	160		
Default Priority:	6		
Parameter Group Number:	65184 (00FEA0 ₁₆)		
Bit Start Position /Bytes	Length	SPN Description	SPN
1-2	2 bytes	Exhaust Gas Port 13 Temperature	1149
3-4	2 bytes	Exhaust Gas Port 14 Temperature	1150
5-6	2 bytes	Exhaust Gas Port 15 Temperature	1151
7-8	2 bytes	Exhaust Gas Port 16 Temperature	1152

pgn65185 - Exhaust Port Temperature 3 - EPT3 -

Transmission Repetition Rate:	1 s		
Data Length:	8 bytes		
Data Page:	0		
PDU Format:	254		
PDU Specific:	161		
Default Priority:	7		
Parameter Group Number:	65185 (00FEA1 ₁₆)		
Bit Start Position /Bytes	Length	SPN Description	SPN
1-2	2 bytes	Exhaust Gas Port 9 Temperature	1145
3-4	2 bytes	Exhaust Gas Port 10 Temperature	1146
5-6	2 bytes	Exhaust Gas Port 11 Temperature	1147
7-8	2 bytes	Exhaust Gas Port 12 Temperature	1148

pgn65186 - Exhaust Port Temperature 2 - EPT2 -

Transmission Repetition Rate:	1 s		
Data Length:	8 bytes		
Data Page:	0		
PDU Format:	254		
PDU Specific:	162		
Default Priority:	7		
Parameter Group Number:	65186 (00FEA2 ₁₆)		
Bit Start Position /Bytes	Length	SPN Description	SPN
1-2	2 bytes	Exhaust Gas Port 5 Temperature	1141
3-4	2 bytes	Exhaust Gas Port 6 Temperature	1142
5-6	2 bytes	Exhaust Gas Port 7 Temperature	1143
7-8	2 bytes	Exhaust Gas Port 8 Temperature	1144

pgn65187 - Exhaust Port Temperature 1 - EPT1 -

Transmission Repetition Rate:	1 s		
Data Length:	8 bytes		
Data Page:	0		
PDU Format:	254		
PDU Specific:	163		
Default Priority:	7		
Parameter Group Number:	65187 (00FEA3 ₁₆)		
Bit Start Position /Bytes	Length	SPN Description	SPN
1-2	2 bytes	Exhaust Gas Port 1 Temperature	1137
3-4	2 bytes	Exhaust Gas Port 2 Temperature	1138
5-6	2 bytes	Exhaust Gas Port 3 Temperature	1139
7-8	2 bytes	Exhaust Gas Port 4 Temperature	1140

pgn65188 - Engine Temperature 2 - ET2 -

Transmission Repetition Rate:	1s		
Data Length:	8 bytes		
Data Page:	0		
PDU Format:	254		
PDU Specific:	164		
Default Priority:	6		
Parameter Group Number:	65188 (00FEA4 ₁₆)		
Bit Start Position /Bytes	Length	SPN Description	SPN
1-2	2 bytes	Engine Oil Temperature 2	1135
3-4	2 bytes	Engine ECU Temperature	1136
5-6	2 bytes	Exhaust Gas Recirculation Differential Pressure	411
7-8	2 bytes	Exhaust Gas Recirculation Temperature	412

pgn65189 - Intake Manifold Information 2 - IMT2 -

Transmission Repetition Rate:	1 s		
Data Length:	8 bytes		
Data Page:	0		
PDU Format:	254		
PDU Specific:	165		
Default Priority:	7		
Parameter Group Number:	65189 (00FEA5 ₁₆)		
Bit Start Position /Bytes	Length	SPN Description	SPN
1	1 byte	Intake Manifold 2 Temperature	1131
2	1 byte	Intake Manifold 3 Temperature	1132
3	1 byte	Intake Manifold 4 Temperature	1133
4	1 byte	Intake Manifold 5 Temperature	1802
5	1 byte	Intake Manifold 6 Temperature	1803

pgn65190 - Intake Manifold Information 1 - IMT1 -

Transmission Repetition Rate:	0.5 s		
Data Length:	8 bytes		
Data Page:	0		
PDU Format:	254		
PDU Specific:	166		
Default Priority:	6		
Parameter Group Number:	65190 (00FEA6 ₁₆)		
Bit Start Position /Bytes	Length	SPN Description	SPN
1-2	2 bytes	Turbocharger 1 Boost Pressure	1127
3-4	2 bytes	Turbocharger 2 Boost Pressure	1128
5-6	2 bytes	Turbocharger 3 Boost Pressure	1129
7-8	2 bytes	Turbocharger 4 Boost Pressure	1130

pgn65191 - Alternator Temperature - AT -

Transmission Repetition Rate:	1 s		
Data Length:	8 bytes		
Data Page:	0		
PDU Format:	254		
PDU Specific:	167		
Default Priority:	7		
Parameter Group Number:	65191 (00FEA7 ₁₆)		
Bit Start Position /Bytes	Length	SPN Description	SPN
1	1 byte	Alternator Bearing 1 Temperature	1122
2	1 byte	Alternator Bearing 2 Temperature	1123
3	1 byte	Alternator Winding 1 Temperature	1124
4	1 byte	Alternator Winding 2 Temperature	1125
5	1 byte	Alternator Winding 3 Temperature	1126

pgn65192 - Articulation Control - AC -

Transmission Repetition Rate:	On request		
Data Length:	8 bytes		
Data Page:	0		
PDU Format:	254		
PDU Specific:	168		
Default Priority:	7		
Parameter Group Number:	65192 (00FEA8 ₁₆)		
Bit Start Position /Bytes	Length	SPN Description	SPN
1	1 byte	Articulation Angle	1120

pgn65193 - Exhaust Oxygen 1 - EO1 -

Transmission Repetition Rate:	On request		
Data Length:	8 bytes		
Data Page:	0		
PDU Format:	254		
PDU Specific:	169		

Default Priority:		7	
Parameter Group Number:		65193 (00FEA9 ₁₆)	
Bit Start Position /Bytes	Length	SPN Description	SPN
1-2	2 bytes	Desired Rated Exhaust Oxygen	1117
3-4	2 bytes	Desired Exhaust Oxygen	1118
5-6	2 bytes	Actual Exhaust Oxygen	1119
7	1 byte	Exhaust Gas Oxygen Sensor Fueling Correction	1695
8.7	2 bits	Exhaust Gas Oxygen Sensor Closed Loop Operation	1696

pgn65194 - Alternate Fuel 2 - AF2 -

Transmission Repetition Rate:		On request	
Data Length:		8 bytes	
Data Page:		0	
PDU Format:		254	
PDU Specific:		170	
Default Priority:		7	
Parameter Group Number:		65194 (00FEAA ₁₆)	
Bit Start Position /Bytes	Length	SPN Description	SPN
1	1 byte	Gaseous Fuel Correction Factor	1116
2-3	2 bytes	Desired Absolute Intake Manifold Pressure (Turbo Boost Limit)	1692
4	1 byte	Wastegate Valve Position	1693
5	1 byte	Gas Mass Flow Sensor Fueling Correction	1694

pgn65195 - Electronic Transmission Controller 6 - ETC6 -

Transmission Repetition Rate:		On request	
Data Length:		8 bytes	
Data Page:		0	
PDU Format:		254	
PDU Specific:		171	
Default Priority:		7	
Parameter Group Number:		65195 (00FEAB ₁₆)	
Bit Start Position /Bytes	Length	SPN Description	SPN
1	1 byte	Recommended Gear	1113
2	1 byte	Highest Possible Gear	1115
3	1 byte	Lowest Possible Gear	1114

pgn65196 - Wheel Brake Lining Remaining Information - EBC4 -

Transmission Repetition Rate:		On request	
Data Length:		8 bytes	
Data Page:		0	
PDU Format:		254	
PDU Specific:		172	
Default Priority:		7	
Parameter Group Number:		65196 (00FEAC ₁₆)	
Bit Start Position /Bytes	Length	SPN Description	SPN

1	1 byte	Brake Lining Remaining, Front Axle, Left Wheel	1099
2	1 byte	Brake Lining Remaining, Front Axle, Right Wheel	1100
3	1 byte	Brake Lining Remaining, Rear Axle #1, Left Wheel	1101
4	1 byte	Brake Lining Remaining, Rear Axle #1, Right Wheel	1102
5	1 byte	Brake Lining Remaining, Rear Axle #2, Left Wheel	1103
6	1 byte	Brake Lining Remaining, Rear Axle #2, Right Wheel	1104
7	1 byte	Brake Lining Remaining, Rear Axle #3, Left Wheel	1105
8	1 byte	Brake Lining Remaining, Rear Axle #3, Right Wheel	1106

pgn65197 - Wheel Application Pressure High Range Information - EBC3 -

Transmission Repetition Rate: 100 ms
 Data Length: 8 bytes
 Data Page: 0
 PDU Format: 254
 PDU Specific: 173
 Default Priority: 6
 Parameter Group Number: 65197 (00FEAD₁₆)

Bit Start Position /Bytes	Length	SPN Description	SPN
1	1 byte	Brake Application Pressure High Range, Front Axle, Left Wheel	1091
2	1 byte	Brake Application Pressure High Range, Front Axle, Right Wheel	1092
3	1 byte	Brake Application Pressure High Range, Rear Axle #1, Left Wheel	1093
4	1 byte	Brake Application Pressure High Range, Rear Axle #1, Right Wheel	1094
5	1 byte	Brake Application Pressure High Range, Rear Axle #2, Left Wheel	1095
6	1 byte	Brake Application Pressure High Range, Rear Axle #2, Right Wheel	1096
7	1 byte	Brake Application Pressure High Range, Rear Axle #3, Left Wheel	1097
8	1 byte	Brake Application Pressure High Range, Rear Axle #3, Right Wheel	1098

pgn65198 - Air Supply Pressure - AIR1 -

Transmission Repetition Rate: 1 s
 Data Length: 8 bytes
 Data Page: 0
 PDU Format: 254
 PDU Specific: 174
 Default Priority: 6
 Parameter Group Number: 65198 (00FEAE₁₆)

Bit Start Position /Bytes	Length	SPN Description	SPN
1	1 byte	Pneumatic Supply Pressure	46
2	1 byte	Parking and/or Trailer Air Pressure	1086
3	1 byte	Service Brake Air Pressure Circuit #1	1087
4	1 byte	Service Brake Air Pressure Circuit #2	1088
5	1 byte	Auxiliary Equipment Supply Pressure	1089
6	1 byte	Air Suspension Supply Pressure	1090

pgn65199 - Fuel Consumption (Gaseous) - GFC -

Transmission Repetition Rate: On request

Data Length:		8 bytes	
Data Page:		0	
PDU Format:		254	
PDU Specific:		175	
Default Priority:		7	
Parameter Group Number:		65199 (00FEAF ₁₆)	
Bit Start Position /Bytes	Length	SPN Description	SPN
1-4	4 bytes	Trip Fuel (Gaseous)	1039
5-8	4 bytes	Total Fuel Used (Gaseous)	1040

pgn65200 - Trip Time Information 2 - TT12 -

Transmission Repetition Rate:		On request	
Data Length:		20 bytes	
Data Page:		0	
PDU Format:		254	
PDU Specific:		176	
Default Priority:		7	
Parameter Group Number:		65200 (00FEB0 ₁₆)	
Bit Start Position /Bytes	Length	SPN Description	SPN
01-04	4 bytes	Trip Cruise Time	1034
05-08	4 bytes	Trip PTO Time	1035
09-12	4 bytes	Trip Engine Running Time	1036
13-16	4 bytes	Trip Idle Time	1037
17-20	4 bytes	Trip Air Compressor On Time	1038

pgn65201 - ECU History - EH -

Transmission Repetition Rate:		On request	
Data Length:		8 bytes	
Data Page:		0	
PDU Format:		254	
PDU Specific:		177	
Default Priority:		7	
Parameter Group Number:		65201 (00FEB1 ₁₆)	
Bit Start Position /Bytes	Length	SPN Description	SPN
1-4	4 bytes	Total ECU Distance	1032
5-8	4 bytes	Total ECU Run Time	1033

pgn65202 - Fuel Information 1 (Gaseous) - GF11 -

Transmission Repetition Rate:		On request	
Data Length:		8 bytes	
Data Page:		0	
PDU Format:		254	
PDU Specific:		178	
Default Priority:		7	
Parameter Group Number:		65202 (00FEB2 ₁₆)	

Bit Start Position /Bytes	Length	SPN Description	SPN
1-4	4 bytes	Total Engine PTO Fuel Used (Gaseous)	1030
5-6	2 bytes	Trip Average Fuel Rate (Gaseous)	1031
7-8	2 bytes	Fuel Specific Gravity	1389

pgn65203 - Fuel Information (Liquid) - LFI -

Transmission Repetition Rate:	On request		
Data Length:	8 bytes		
Data Page:	0		
PDU Format:	254		
PDU Specific:	179		
Default Priority:	7		
Parameter Group Number:	65203 (00FEB3 ₁₆)		
Bit Start Position /Bytes	Length	SPN Description	SPN
1-4	4 bytes	Total Engine PTO Fuel Used	1028
5-6	2 bytes	Trip Average Fuel Rate	1029

pgn65204 - Trip Time Information 1 - TT11 -

Transmission Repetition Rate:	On request		
Data Length:	16 bytes		
Data Page:	0		
PDU Format:	254		
PDU Specific:	180		
Default Priority:	7		
Parameter Group Number:	65204 (00FEB4 ₁₆)		
Bit Start Position /Bytes	Length	SPN Description	SPN
01-04	4 bytes	Trip Time in VSL	1024
05-08	4 bytes	Trip Time in Top Gear	1025
09-12	4 bytes	Trip Time in Gear Down	1026
13-16	4 bytes	Trip Time in Derate by Engine	1027

pgn65205 - Trip Shutdown Information - TSI -

Transmission Repetition Rate:	On request		
Data Length:	8 bytes		
Data Page:	0		
PDU Format:	254		
PDU Specific:	181		
Default Priority:	7		
Parameter Group Number:	65205 (00FEB5 ₁₆)		
Bit Start Position /Bytes	Length	SPN Description	SPN
1-2	2 bytes	Trip Number of Hot Shutdowns	1020
3-4	2 bytes	Trip Number of Idle Shutdowns	1021
5-6	2 bytes	Trip Number of Idle Shutdown Overrides	1022
7-8	2 bytes	Trip Sudden Decelerations	1023

pgn65206 - Trip Vehicle Speed/Cruise Distance Information - TVI -

Transmission Repetition Rate:	On request		
Data Length:	8 bytes		
Data Page:	0		
PDU Format:	254		
PDU Specific:	182		
Default Priority:	7		
Parameter Group Number:	65206 (00FEB6 ₁₆)		
Bit Start Position /Bytes	Length	SPN Description	SPN
1-2	2 bytes	Trip Maximum Vehicle Speed	1018
3-6	4 bytes	Trip Cruise Distance	1019

pgn65207 - Engine Speed/Load Factor Information - LF -

Transmission Repetition Rate:	On request		
Data Length:	10 bytes		
Data Page:	0		
PDU Format:	254		
PDU Specific:	183		
Default Priority:	7		
Parameter Group Number:	65207 (00FEB7 ₁₆)		
Bit Start Position /Bytes	Length	SPN Description	SPN
1-2	2 bytes	Trip Maximum Engine Speed	1013
3-4	2 bytes	Trip Average Engine Speed	1014
5	1 byte	Trip Drive Average Load Factor	1015
6	1 byte	Total Drive Average Load Factor	1016
7-10	4 bytes	Total Engine Cruise Time	1017

pgn65208 - Trip Fuel Information (Gaseous) - GTFI -

Transmission Repetition Rate:	On request		
Data Length:	22 bytes		
Data Page:	0		
PDU Format:	254		
PDU Specific:	184		
Default Priority:	7		
Parameter Group Number:	65208 (00FEB8 ₁₆)		
Bit Start Position /Bytes	Length	SPN Description	SPN
01-04	4 bytes	Trip Drive Fuel Used (Gaseous)	1007
05-08	4 bytes	Trip PTO Moving Fuel Used (Gaseous)	1008
09-12	4 bytes	Trip PTO Non-moving Fuel Used (Gaseous)	1009
13-16	4 bytes	Trip Vehicle Idle Fuel Used (Gaseous)	1010
17-20	4 bytes	Trip Cruise Fuel Used (Gaseous)	1011
21-22	2 bytes	Trip Drive Fuel Economy (Gaseous)	1012

pgn65209 - Trip Fuel Information (Liquid) - LTFI -

Transmission Repetition Rate:	On request		
Data Length:	22 bytes		
Data Page:	0		
PDU Format:	254		
PDU Specific:	185		
Default Priority:	7		
Parameter Group Number:	65209 (00FEB9 ₁₆)		
Bit Start Position /Bytes	Length	SPN Description	SPN
01-04	4 bytes	Trip Drive Fuel Used	1001
05-08	4 bytes	Trip PTO Moving Fuel Used	1002
09-12	4 bytes	Trip PTO Non-moving Fuel Used	1003
13-16	4 bytes	Trip Vehicle Idle Fuel Used	1004
17-20	4 bytes	Trip Cruise Fuel Used	1005
21-22	2 bytes	Trip Drive Fuel Economy	1006

pgn65210 - Trip Distance Information - TDI -

Transmission Repetition Rate:	On request		
Data Length:	12 bytes		
Data Page:	0		
PDU Format:	254		
PDU Specific:	186		
Default Priority:	7		
Parameter Group Number:	65210 (00FEBA ₁₆)		
Bit Start Position /Bytes	Length	SPN Description	SPN
1-4	4 bytes	Trip Distance on VSL	998
5-8	4 bytes	Trip Gear Down Distance	999
9-12	4 bytes	Trip Distance in Top Gear	1000

pgn65211 - Trip Fan Information - TFI -

Transmission Repetition Rate:	On request		
Data Length:	16 bytes		
Data Page:	0		
PDU Format:	254		
PDU Specific:	187		
Default Priority:	7		
Parameter Group Number:	65211 (00FEBA ₁₆)		
Bit Start Position /Bytes	Length	SPN Description	SPN
01-04	4 bytes	Trip Fan On Time	994
05-08	4 bytes	Trip Fan On Time Due to the Engine System	995
09-12	4 bytes	Trip Fan On Time Due to a Manual Switch	996
13-16	4 bytes	Trip Fan On Time Due to the A/C System	997

pgn65212 - Compression/Service Brake Information - CBI -

Transmission Repetition Rate:	On request
Data Length:	16 bytes

Data Page:	0		
PDU Format:	254		
PDU Specific:	188		
Default Priority:	7		
Parameter Group Number:	65212 (00FEBC ₁₆)		
Bit Start Position /Bytes	Length	SPN Description	SPN
01-04	4 bytes	Total Compression Brake Distance	990
05-08	4 bytes	Trip Compression Brake Distance	991
09-12	4 bytes	Trip Service Brake Distance	992
13-16	4 bytes	Trip Service Brake Applications	993

pgn65213 - Fan Drive - FD -

Transmission Repetition Rate:	1 s		
Data Length:	8 bytes		
Data Page:	0		
PDU Format:	254		
PDU Specific:	189		
Default Priority:	6		
Parameter Group Number:	65213 (00FEBD ₁₆)		
Bit Start Position /Bytes	Length	SPN Description	SPN
1	1 byte	Estimated Percent Fan Speed	975
2.1	4 bits	Fan Drive State	977
3-4	2 bytes	Fan Speed	1639

This parameter group transfers status and measured information on the engine coolant fan.

pgn65214 - Electronic Engine Controller 4 - EEC4 -

Transmission Repetition Rate:	On request		
Data Length:	8 bytes		
Data Page:	0		
PDU Format:	254		
PDU Specific:	190		
Default Priority:	7		
Parameter Group Number:	65214 (00FEBE ₁₆)		
Bit Start Position /Bytes	Length	SPN Description	SPN
1-2	2 bytes	Rated Engine Power	166
3-4	2 bytes	Rated Engine Speed	189

pgn65215 - Wheel Speed Information - EBC2 -

Transmission Repetition Rate:	100 ms		
Data Length:	8 bytes		
Data Page:	0		
PDU Format:	254		
PDU Specific:	191		
Default Priority:	6		
Parameter Group Number:	65215 (00FEBF ₁₆)		

Bit Start Position /Bytes	Length	SPN Description	SPN
1-2	2 bytes	Front Axle Speed	904
3	1 byte	Relative Speed; Front Axle, Left Wheel	905
4	1 byte	Relative Speed; Front Axle, Right Wheel	906
5	1 byte	Relative Speed; Rear Axle #1, Left Wheel	907
6	1 byte	Relative Speed; Rear Axle #1, Right Wheel	908
7	1 byte	Relative Speed; Rear Axle #2, Left Wheel	909
8	1 byte	Relative Speed; Rear Axle #2, Right Wheel	910

pgn65216 - Service Information - SERV -

Transmission Repetition Rate:	On request
Data Length:	8 bytes or variable bytes
Data Page:	0
PDU Format:	254
PDU Specific:	192
Default Priority:	6
Parameter Group Number:	65216 (00FEC0 ₁₆)

Bit Start Position /Bytes	Length	SPN Description	SPN
1	1 byte	Service Component Identification	911
2-3	2 bytes	Service Distance	914
4	1 byte	Service Component Identification	912
5	1 byte	Service Delay/Calendar Time Based	915
6	1 byte	Service Component Identification	913
7-8	2 bytes	Service Delay/Operational Time Based	916

Transmitted with the service component identification that has the shortest distance or nearest time until the next service inspection.

NOTE - There are two acceptable formats for the Service PGN. Format 1 has only 8 bytes of data and reports the component most in need of service for each of the three categories. Format 2, however, uses the transport layer as necessary in order to repeat these 8 bytes of service component information until all supported service components in each category have been transmitted.

pgn65217 - High Resolution Vehicle Distance - VDHR -

Transmission Repetition Rate:	1 s
Data Length:	8 bytes
Data Page:	0
PDU Format:	254
PDU Specific:	193
Default Priority:	6
Parameter Group Number:	65217 (00FEC1 ₁₆)

Bit Start Position /Bytes	Length	SPN Description	SPN
1-4	4 bytes	High Resolution Total Vehicle Distance	917
5-8	4 bytes	High Resolution Trip Distance	918

pgn65218 - Electronic Retarder Controller 2 - ERC2 -

Transmission Repetition Rate:	1 s when active; or on change of state
Data Length:	8 bytes
Data Page:	0

PDU Format:	254		
PDU Specific:	194		
Default Priority:	7		
Parameter Group Number:	65218 (00FEC2 ₁₆)		
Bit Start Position /Bytes	Length	SPN Description	SPN
1.1	2 bits	Transmission Output Retarder	748

pgn65219 - Electronic Transmission Controller 5 - ETC5 -

Transmission Repetition Rate:	On request		
Data Length:	8 bytes		
Data Page:	0		
PDU Format:	254		
PDU Specific:	195		
Default Priority:	7		
Parameter Group Number:	65219 (00FEC3 ₁₆)		
Bit Start Position /Bytes	Length	SPN Description	SPN
1.1	2 bits	Transmission High Range Sense Switch	778
1.3	2 bits	Transmission Low Range Sense Switch	779
2.1	2 bits	Transmission Reverse Direction Switch	767
2.3	2 bits	Transmission Neutral Switch	604
2.5	2 bits	Transmission Forward Direction Switch	903

pgn65221 - Electronic Transmission Controller 4 - ETC4 -

Transmission Repetition Rate:	On request		
Data Length:	8 bytes		
Data Page:	0		
PDU Format:	254		
PDU Specific:	197		
Default Priority:	7		
Parameter Group Number:	65221 (00FEC5 ₁₆)		
Bit Start Position /Bytes	Length	SPN Description	SPN
1	1 byte	Transmission Synchronizer Clutch Value	53
2	1 byte	Transmission Synchronizer Brake Value	54

pgn65223 - Electronic Transmission Controller 3 - ETC3 -

Transmission Repetition Rate:	On request		
Data Length:	8 bytes		
Data Page:	0		
PDU Format:	254		
PDU Specific:	199		
Default Priority:	7		
Parameter Group Number:	65223 (00FEC7 ₁₆)		
Bit Start Position /Bytes	Length	SPN Description	SPN
1	1 byte	Shift Finger Gear Position	59
2	1 byte	Shift Finger Rail Position	60

3.1	2 bits	Shift Finger Neutral Indicator	780
3.3	2 bits	Shift Finger Engagement Indicator	781
3.5	2 bits	Shift Finger Center Rail Indicator	782
4.1	2 bits	Shift Finger Rail Actuator 1	772
4.3	2 bits	Shift Finger Gear Actuator 1	773
4.5	2 bits	Shift Finger Rail Actuator 2	783
4.7	2 bits	Shift Finger Gear Actuator 2	784
5.1	2 bits	Range High Actuator	768
5.3	2 bits	Range Low Actuator	769
5.5	2 bits	Splitter Direct Actuator	770
5.7	2 bits	Splitter Indirect Actuator	771
6.1	2 bits	Clutch Actuator	788
6.3	2 bits	Lockup Clutch Actuator	740
6.5	2 bits	Defuel Actuator	786
6.7	2 bits	Inertia Brake Actuator	787

pgn65237 - Alternator Speed - AS -

Transmission Repetition Rate:	1 s		
Data Length:	8 bytes		
Data Page:	0		
PDU Format:	254		
PDU Specific:	213		
Default Priority:	6		
Parameter Group Number:	65237 (00FED5 ₁₆)		
Bit Start Position /Bytes	Length	SPN Description	SPN
1-2	2 bytes	Alternator Speed	589

pgn65241 - Auxiliary Input/Output Status - AUXIO -

Transmission Repetition Rate:	manufacturer defined, not faster than 100 ms		
Data Length:	8 bytes		
Data Page:	0		
PDU Format:	254		
PDU Specific:	217		
Default Priority:	6		
Parameter Group Number:	65241 (00FED9 ₁₆)		
Bit Start Position /Bytes	Length	SPN Description	SPN
1.1	2 bits	Auxiliary I/O #04	704
1.3	2 bits	Auxiliary I/O #03	703
1.5	2 bits	Auxiliary I/O #02	702
1.7	2 bits	Auxiliary I/O #01	701
2.1	2 bits	Auxiliary I/O #08	708
2.3	2 bits	Auxiliary I/O #07	707
2.5	2 bits	Auxiliary I/O #06	706
2.7	2 bits	Auxiliary I/O #05	705
3.1	2 bits	Auxiliary I/O #12	712

3.3	2 bits	Auxiliary I/O #11	711
3.5	2 bits	Auxiliary I/O #10	710
3.7	2 bits	Auxiliary I/O #09	709
4.1	2 bits	Auxiliary I/O #16	716
4.3	2 bits	Auxiliary I/O #15	715
4.5	2 bits	Auxiliary I/O #14	714
4.7	2 bits	Auxiliary I/O #13	713
5-6	2 bytes	Auxiliary I/O Channel #1	1083
7-8	2 bytes	Auxiliary I/O Channel #2	1084

pgn65242 - Software Identification - SOFT -

Transmission Repetition Rate:	On request		
Data Length:	Variable bytes		
Data Page:	0		
PDU Format:	254		
PDU Specific:	218		
Default Priority:	6		
Parameter Group Number:	65242 (00FEDA ₁₆)		
Bit Start Position /Bytes	Length	SPN Description	SPN
1	1 byte	Number of Software Identification Fields	965
2-N	Variable - up to 200 characters ("*" delimited)	Software Identification	234

Byte: 1 Number of software identification fields 2-n Software identification(s) Delimiter (ASCII '*') NOTE- The software identification field is variable in length and may contain up to 125 software identification designators. An ASCII '*' is used as a delimiter to separate multiple software identifications. Additional software identification fields may be added at the end, each separated by an ASCII '*' as a delimiter. An ASCII '*' is required at the end of the last software identification field, even if there is only one software identification designator.

pgn65243 - Engine Fluid Level/Pressure 2 - EFL/P2 -

Transmission Repetition Rate:	0.5 s		
Data Length:	8 bytes		
Data Page:	0		
PDU Format:	254		
PDU Specific:	219		
Default Priority:	6		
Parameter Group Number:	65243 (00FEDB ₁₆)		
Bit Start Position /Bytes	Length	SPN Description	SPN
1-2	2 bytes	Injection Control Pressure	164
3-4	2 bytes	Injector Metering Rail 1 Pressure	157
5-6	2 bytes	Injector Timing Rail 1 Pressure	156
7-8	2 bytes	Injector Metering Rail 2 Pressure	1349

pgn65244 - Idle Operation - IO -

Transmission Repetition Rate:	On request
-------------------------------	------------

Data Length:		Variable bytes	
Data Page:		0	
PDU Format:		254	
PDU Specific:		220	
Default Priority:		6	
Parameter Group Number:		65244 (00FEDC ₁₆)	
Bit Start Position /Bytes	Length	SPN Description	SPN
1-4	4 bytes	Total Idle Fuel Used	236
5-8	4 bytes	Total Idle Hours	235

pgn65245 - Turbocharger - TC -

Transmission Repetition Rate:		1 s	
Data Length:		8 bytes	
Data Page:		0	
PDU Format:		254	
PDU Specific:		221	
Default Priority:		6	
Parameter Group Number:		65245 (00FEDD ₁₆)	
Bit Start Position /Bytes	Length	SPN Description	SPN
1	1 byte	Turbocharger Lube Oil Pressure 1	104
2-3	2 bytes	Turbocharger 1 Speed	103
4.7	2 bits	Turbo Oil Level Switch	1665

pgn65246 - Air Start Pressure - AIR2 -

Transmission Repetition Rate:		On request	
Data Length:		8 bytes	
Data Page:		0	
PDU Format:		254	
PDU Specific:		222	
Default Priority:		6	
Parameter Group Number:		65246 (00FEDE ₁₆)	
Bit Start Position /Bytes	Length	SPN Description	SPN
1	1 byte	Air Start Pressure	82

pgn65247 - Electronic Engine Controller 3 - EEC3 -

Transmission Repetition Rate:		250 msecs	
Data Length:		8 bytes	
Data Page:		0	
PDU Format:		254	
PDU Specific:		223	
Default Priority:		6	
Parameter Group Number:		65247 (00FEDF ₁₆)	
Bit Start Position /Bytes	Length	SPN Description	SPN
1	1 byte	Nominal Friction - Percent Torque	514
2-3	2 bytes	Engine's Desired Operating Speed	515

4	1 byte	Engine's Desired Operating Speed Asymmetry Adjustment	519
---	--------	---	-----

pgn65248 - Vehicle Distance - VD -

Transmission Repetition Rate:	100 ms		
Data Length:	8 bytes		
Data Page:	0		
PDU Format:	254		
PDU Specific:	224		
Default Priority:	6		
Parameter Group Number:	65248 (00FEE0 ₁₆)		
Bit Start Position /Bytes	Length	SPN Description	SPN
1-4	4 bytes	Trip Distance	244
5-8	4 bytes	Total Vehicle Distance	245

pgn65249 - Retarder Configuration - RC -

Transmission Repetition Rate:	On change of torque/speed points of more than 10% since last transmission, or every 5 s.		
Data Length:	19 bytes		
Data Page:	0		
PDU Format:	254		
PDU Specific:	225		
Default Priority:	6		
Parameter Group Number:	65249 (00FEE1 ₁₆)		
Bit Start Position /Bytes	Length	SPN Description	SPN
01.1	4 bits	Retarder Type	901
01.5	4 bits	Retarder Location	902
02	1 byte	Retarder Control Method (Retarder Configuration)	557
03-04	2 bytes	Retarder Speed At Idle, Point 1 (Retarder Configuration)	546
05	1 byte	Percent Torque At Idle, Point 1 (Retarder Configuration)	551
06-07	2 bytes	Maximum Retarder Speed, Point 2 (Retarder Configuration)	548
08	1 byte	Percent Torque At Maximum Speed, Point 2 (Retarder Configuration)	552
09-10	2 bytes	Retarder Speed At Point 3 (Retarder Configuration)	549
11	1 byte	Percent Torque At Point 3 (Retarder Configuration)	553
12-13	2 bytes	Retarder Speed At Point 4 (Retarder Configuration)	550
14	1 byte	Percent Torque At Point 4 (Retarder Configuration)	554
15-16	2 bytes	Retarder Speed At Peak Torque, Point 5 (Retarder Configuration)	547
17-18	2 bytes	Reference Retarder Torque (Retarder Configuration)	556
19	1 byte	Percent Torque At Peak Torque, Point 5 (Retarder Configuration)	555

This map describes the stationary behavior of the retarder.

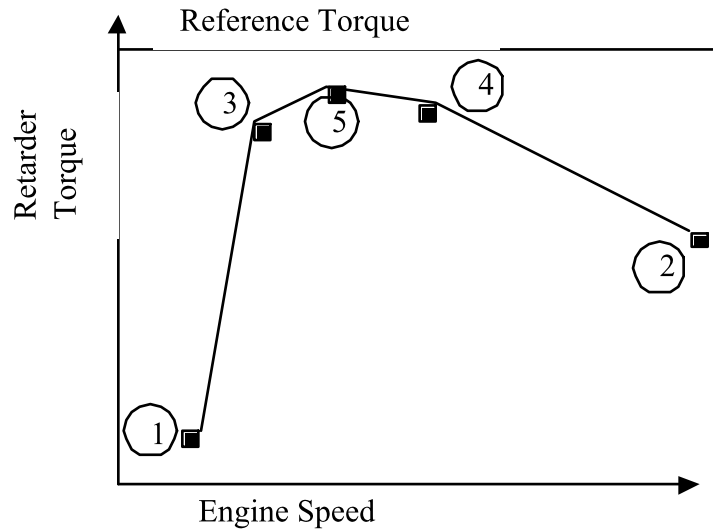

FIGURE PGN65249_A -- TYPICAL HYDRAULIC RETARDER TORQUE CURVE

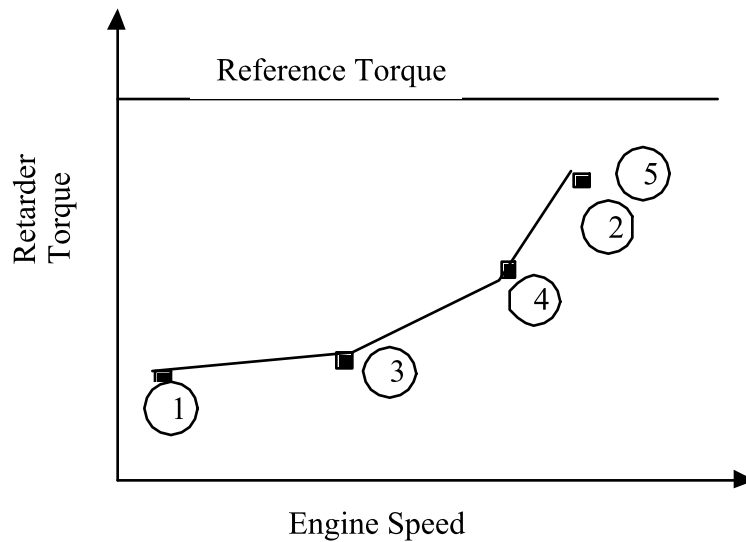

FIGURE PGN65249_B -- TYPICAL ENGINE COMPRESSION BRAKE TORQUE CURVE

pgn65250 - Transmission Configuration - TCFG -

Transmission Repetition Rate:	On request		
Data Length:	Variable bytes		
Data Page:	0		
PDU Format:	254		
PDU Specific:	226		
Default Priority:	6		
Parameter Group Number:	65250 (00FEE2 ₁₆)		
Bit Start Position /Bytes	Length	SPN Description	SPN
1	1 byte	Number of Reverse Gear Ratios	958
2	1 byte	Number of Forward Gear Ratios	957
3-4	2 bytes	Transmission Gear Ratio	581

Total message length depends on total number of forward and reverse gear ratios.

The first gear ratio transmitted in bytes 3,4 will be the highest reverse gear ratio.
Additional 2-byte gear ratios will follow:

3,4	Highest forward gear ratio
.	
a,b	Lowest reverse gear ratio
c,d	Lowest forward gear ratio
.	
e,f	Highest forward gear ratio

pgn65251 - Engine Configuration - EC -

Transmission Repetition Rate:	On change of torque/speed points of more than 10% since last transmission. Alternatively , or every 5 s.
Data Length:	34 bytes
Data Page:	0
PDU Format:	254
PDU Specific:	227
Default Priority:	6
Parameter Group Number:	65251 (00FEE3 ₁₆)

Bit Start Position /Bytes	Length	SPN Description	SPN
1-2	2 bytes	Engine Speed At Idle, Point 1 (Engine Configuration)	188
3	1 byte	Percent Torque At Idle, Point 1 (Engine Configuration)	539
4-5	2 bytes	Engine Speed At Point 2 (Engine Configuration)	528
6	1 byte	Percent Torque At Point 2 (Engine Configuration)	540
7-8	2 bytes	Engine Speed At Point 3 (Engine Configuration)	529
9	1 byte	Percent Torque At Point 3 (Engine Configuration)	541
10-11	2 bytes	Engine Speed At Point 4 (Engine Configuration)	530
12	1 byte	Percent Torque At Point 4 (Engine Configuration)	542
13-14	2 bytes	Engine Speed At Point 5 (Engine Configuration)	531
15	1 byte	Percent Torque At Point 5 (Engine Configuration)	543
16-17	2 bytes	Engine Speed At High Idle, Point 6 (Engine Configuration)	532
18-19	2 bytes	Gain (Kp) Of The Endspeed Governor (Engine Configuration)	545
20-21	2 bytes	Reference Engine Torque (Engine Configuration)	544
22-23	2 bytes	Maximum Momentary Engine Override Speed, Point 7 (Engine Configuration)	533
24	1 byte	Maximum Momentary Override Time Limit (Engine Configuration)	534
25	1 byte	Requested Speed Control Range Lower Limit (Engine Configuration)	535
26	1 byte	Requested Speed Control Range Upper Limit (Engine Configuration)	536
27	1 byte	Requested Torque Control Range Lower Limit (Engine Configuration)	537
28	1 byte	Requested Torque Control Range Upper Limit (Engine Configuration)	538
29-30	2 bytes	Extended Range Requested Speed Control Range Upper Limit (Engine configuration)	1712
31-32	2 bytes	Engine Moment of Inertia	1794
33-34	2 bytes	Default Engine Torque Limit	1846

This map describes the stationary behavior of the engine and the speed dependent available indicated torque. This map should reflect the effect of changes due to barometric pressure, engine temperature, and any other stationary changes (sensor failures, etc.) which influence the engine torque curve more than 10%. This map is only valid for maximum boost pressure. At low boost pressures the

torque limit may be much lower. The engine configuration message must be sent at any time that the engine configuration map has changed by more than 10% of speed or torque (due to events other than boost pressure) since that last time the message was transmitted. As an alternative, it may be sent periodically, once every 5 s. It shall also be sent on response to a configuration request message. The engine characteristic can be described in one of three modes. Mode 1 provides a complete curve of speed and torque points (see Figure 9). Modes 2 and 3 provide a partial curve of speed and torque points and a separate endspeed governor characteristic. In modes 2 and 3, the receiver of the engine configuration message has to calculate the minimum of the engine torque curve and the endspeed governor characteristic to get the final available engine torque. Mode 2 provides a high idle point where torque equals zero (point 6) and the endspeed governor gain Kp (see Figure 10). Mode 3 provides the kick-in point of the endspeed governor (point 2) and the governor gain Kp (see Figure 11). The selection of the three modes can be done by setting the parameters as shown in Table 14.

Mode	Torque/Speed Point 2	Governor Gain KP	High Idle Speed
1	Available	Not available	Available
2	Not Available	Available	Available
3	Available	Available	Not available

The following points are shown in Figures PGN65251_A, PGN65251_B, and PGN65251_C.

- Point 1 (required): Torque/speed point at idle
- Point 2 (required): Mode 1 & 3: Torque/speed point at which the high speed governor becomes active
Mode 2: Normal torque/speed point
- Point 3,4,5 (required): Torque/speed points between points 1 and 2 to permit linear interpolation over the entire torque range. It is required that one of these points indicate the peak torque point for the current engine torque map.
- Point 6 (mode dependent): Mode 1 & 2: High idle speed (torque = 0)
Mode 3: Not available (point is defined by the endspeed governor where torque = 0)
- Point 7 (optional): Maximum momentary engine override speed (torque = 0)
- Reference engine torque: Engine torque in Nm. This parameter is the reference value of 100% for all defined indicated engine torque parameters. It is only defined once and doesn't change if a different engine torque map becomes valid.

TABLE PGN65251_A -- ENGINE CONFIGURATION CHARACTERISTIC MODES

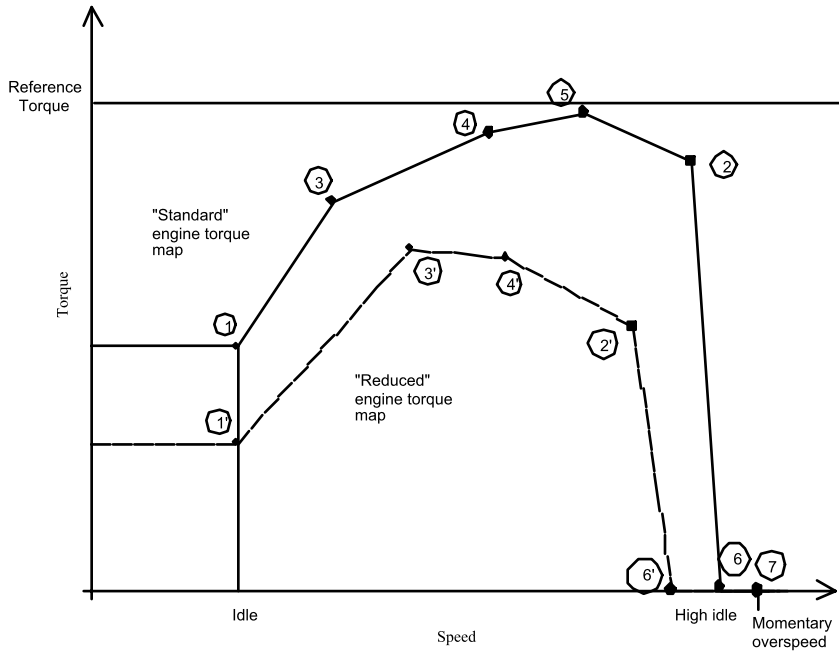

FIGURE PGN65251_A -- ENGINE CONFIGURATION MAP-MODE 1

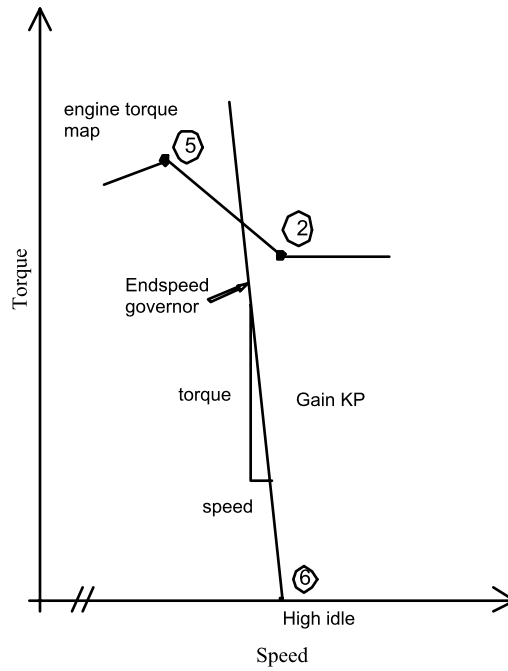

FIGURE PGN65251_B -- ENGINE CONFIGURATION MAP-MODE 2

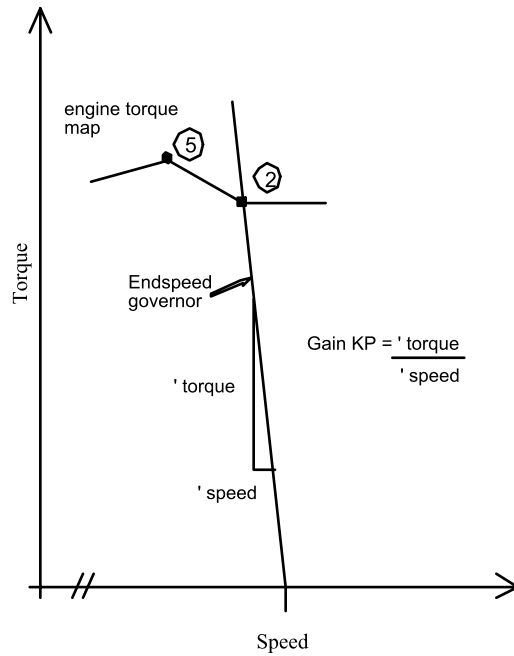

FIGURE PGN65251_C -- ENGINE CONFIGURATION MAP-MODE 3

pgn65252 - Shutdown - SHUTDOWN -

Transmission Repetition Rate: 1 s
 Data Length: 8 bytes
 Data Page: 0
 PDU Format: 254
 PDU Specific: 228
 Default Priority: 6
 Parameter Group Number: 65252 (00FEE4₁₆)

Bit Start Position /Bytes	Length	SPN Description	SPN
1.1	2 bits	Idle Shutdown has Shutdown Engine	593
1.3	2 bits	Idle Shutdown Driver Alert Mode	594
1.5	2 bits	Idle Shutdown Timer Override	592
1.7	2 bits	Idle Shutdown Timer State	590
2.7	2 bits	Idle Shutdown Timer Function	591
3.1	2 bits	A/C High Pressure Fan Switch	985
3.3	2 bits	Refrigerant Low Pressure Switch	875
3.5	2 bits	Refrigerant High Pressure Switch	605
4.1	2 bits	Wait to Start Lamp	1081
5.1	2 bits	Engine Protection System has Shutdown Engine	1110
5.3	2 bits	Engine Protection System Approaching Shutdown	1109
5.5	2 bits	Engine Protection System Timer Override	1108
5.7	2 bits	Engine Protection System Timer State	1107
6.7	2 bits	Engine Protection System Configuration	1111

pgn65253 - Engine Hours, Revolutions - HOURS -

Transmission Repetition Rate:	On request		
Data Length:	8 bytes		
Data Page:	0		
PDU Format:	254		
PDU Specific:	229		
Default Priority:	6		
Parameter Group Number:	65253 (00FEE5 ₁₆)		
Bit Start Position /Bytes	Length	SPN Description	SPN
1-4	4 bytes	Total Engine Hours	247
5-8	4 bytes	Total Engine Revolutions	249

pgn65254 - Time/Date - TD -

Transmission Repetition Rate:	On request		
Data Length:	8 bytes		
Data Page:	0		
PDU Format:	254		
PDU Specific:	230		
Default Priority:	6		
Parameter Group Number:	65254 (00FEE6 ₁₆)		
Bit Start Position /Bytes	Length	SPN Description	SPN
1	1 byte	Seconds	959
2	1 byte	Minutes	960
3	1 byte	Hours	961
4	1 byte	Month	963
5	1 byte	Day	962
6	1 byte	Year	964
7	1 byte	Local minute offset	1601
8	1 byte	Local hour offset	1602

pgn65255 - Vehicle Hours - VH -

Transmission Repetition Rate:	On request		
Data Length:	8 bytes		
Data Page:	0		
PDU Format:	254		
PDU Specific:	231		
Default Priority:	6		
Parameter Group Number:	65255 (00FEE7 ₁₆)		
Bit Start Position /Bytes	Length	SPN Description	SPN
1-4	4 bytes	Total Vehicle Hours	246
5-8	4 bytes	Total Power Takeoff Hours	248

pgn65256 - Vehicle Direction/Speed - VDS -

Transmission Repetition Rate:	On request		
Data Length:	8 bytes		
Data Page:	0		

PDU Format:		254	
PDU Specific:		232	
Default Priority:		6	
Parameter Group Number:		65256 (00FEE8 ₁₆)	
Bit Start Position /Bytes	Length	SPN Description	SPN
1-2	2 bytes	Compass Bearing	165
3-4	2 bytes	Navigation-Based Vehicle Speed	517
5-6	2 bytes	Pitch	583
7-8	2 bytes	Altitude	580

pgn65257 - Fuel Consumption (Liquid) - LFC -

Transmission Repetition Rate:		On request	
Data Length:		8 bytes	
Data Page:		0	
PDU Format:		254	
PDU Specific:		233	
Default Priority:		6	
Parameter Group Number:		65257 (00FEE9 ₁₆)	
Bit Start Position /Bytes	Length	SPN Description	SPN
1-4	4 bytes	Trip Fuel	182
5-8	4 bytes	Total Fuel Used	250

pgn65258 - Vehicle Weight - VW -

Transmission Repetition Rate:		On request	
Data Length:		8 bytes	
Data Page:		0	
PDU Format:		254	
PDU Specific:		234	
Default Priority:		6	
Parameter Group Number:		65258 (00FEEA ₁₆)	
Bit Start Position /Bytes	Length	SPN Description	SPN
1	8 bits	Axle Location	928
2-3	2 bytes	Axle Weight	582
4-5	2 bytes	Trailer Weight	180
6-7	2 bytes	Cargo Weight	181

NOTE: Request has to be responded to with as many messages as necessary to transmit all available information.

pgn65259 - Component Identification - CI -

Transmission Repetition Rate:		On request	
Data Length:		Variable bytes	
Data Page:		0	
PDU Format:		254	
PDU Specific:		235	
Default Priority:		6	
Parameter Group Number:		65259 (00FEEB ₁₆)	

Bit Start Position /Bytes	Length	SPN Description	SPN
a	5 bytes	Make	586
b	Variable - up to 200 characters ("*" delimited)	Model	587
c	Variable - up to 200 characters ("*" delimited)	Serial Number	588
d	Variable - up to 200 characters ("*" delimited)	Unit Number (Power Unit)	233

NOTE - The make, model, serial number and unit number fields in this message are optional and separated by an ASCII "*". It is not necessary to include all fields; however, the delimiter ("*") is always required.

Field:
a Make
Delimiter (ASCII "*")
b Model
Delimiter (ASCII "*")
c Serial number
Delimiter (ASCII "*")
d Unit number (Power unit)
Delimiter (ASCII "*")

pgn65260 - Vehicle Identification - VI -

Transmission Repetition Rate:	On request		
Data Length:	Variable bytes		
Data Page:	0		
PDU Format:	254		
PDU Specific:	236		
Default Priority:	6		
Parameter Group Number:	65260 (00FEEC ₁₆)		
Bit Start Position /Bytes	Length	SPN Description	SPN
1	Variable - up to 200 characters ("*" delimited)	Vehicle Identification Number	237

Byte: 1-n Vehicle Identification Number Delimiter (ASCII "*")

pgn65261 - Cruise Control/Vehicle Speed Setup - CCSS -

Transmission Repetition Rate:	On request		
Data Length:	8 bytes		
Data Page:	0		
PDU Format:	254		
PDU Specific:	237		
Default Priority:	6		
Parameter Group Number:	65261 (00FEED ₁₆)		
Bit Start Position /Bytes	Length	SPN Description	SPN
1	1 byte	Maximum Vehicle Speed Limit	74
2	1 byte	Cruise Control High Set Limit Speed	87

3 1 byte Cruise Control Low Set Limit Speed 88

pgn65262 - Engine Temperature 1 - ET1 -

Transmission Repetition Rate: 1 s
 Data Length: 8 bytes
 Data Page: 0
 PDU Format: 254
 PDU Specific: 238
 Default Priority: 6
 Parameter Group Number: 65262 (00FEEE₁₆)

Bit Start Position /Bytes	Length	SPN Description	SPN
1	1 byte	Engine Coolant Temperature	110
2	1 byte	Fuel Temperature	174
3-4	2 bytes	Engine Oil Temperature 1	175
5-6	2 bytes	Turbo Oil Temperature	176
7	1 byte	Engine Intercooler Temperature	52
8	1 byte	Engine Intercooler Thermostat Opening	1134

pgn65263 - Engine Fluid Level/Pressure 1 - EFL/P1 -

Transmission Repetition Rate: 0.5 s
 Data Length: 8 bytes
 Data Page: 0
 PDU Format: 254
 PDU Specific: 239
 Default Priority: 6
 Parameter Group Number: 65263 (00FEEF₁₆)

Bit Start Position /Bytes	Length	SPN Description	SPN
1	1 byte	Fuel Delivery Pressure	94
2	1 byte	Extended Crankcase Blow-by Pressure	22
3	1 byte	Engine Oil Level	98
4	1 byte	Engine Oil Pressure	100
5-6	2 bytes	Crankcase Pressure	101
7	1 byte	Coolant Pressure	109
8	1 byte	Coolant Level	111

pgn65264 - Power Takeoff Information - PTO -

Transmission Repetition Rate: 100 ms
 Data Length: 8 bytes
 Data Page: 0
 PDU Format: 254
 PDU Specific: 240
 Default Priority: 6
 Parameter Group Number: 65264 (00FEF0₁₆)

Bit Start Position /Bytes	Length	SPN Description	SPN
1	1 byte	Power Takeoff Oil Temperature	90

2-3	2 bytes	Power Takeoff Speed	186
4-5	2 bytes	Power Takeoff Set Speed	187
6.1	2 bits	PTO Enable Switch	980
6.3	2 bits	Remote PTO Preprogrammed Speed Control Switch	979
6.5	2 bits	Remote PTO Variable Speed Control Switch	978
7.1	2 bits	PTO Set Switch	984
7.3	2 bits	PTO Coast/Decelerate Switch	983
7.5	2 bits	PTO Resume Switch	982
7.7	2 bits	PTO Accelerate Switch	981

pgn65265 - Cruise Control/Vehicle Speed - CCVS -

Transmission Repetition Rate:	100 ms		
Data Length:	8 bytes		
Data Page:	0		
PDU Format:	254		
PDU Specific:	241		
Default Priority:	6		
Parameter Group Number:	65265 (00FEF1 ₁₆)		
Bit Start Position /Bytes	Length	SPN Description	SPN
1.1	2 bits	Two Speed Axle Switch	69
1.3	2 bits	Parking Brake Switch	70
1.5	2 bits	Cruise Control Pause Switch	1633
2-3	2 bytes	Wheel-Based Vehicle Speed	84
4.1	2 bits	Cruise Control Active	595
4.3	2 bits	Cruise Control Enable Switch	596
4.5	2 bits	Brake Switch	597
4.7	2 bits	Clutch Switch	598
5.1	2 bits	Cruise Control Set Switch	599
5.3	2 bits	Cruise Control Coast (Decelerate) Switch	600
5.5	2 bits	Cruise Control Resume Switch	601
5.7	2 bits	Cruise Control Accelerate Switch	602
6	1 byte	Cruise Control Set Speed	86
7.1	5 bits	PTO State	976
7.6	3 bits	Cruise Control States	527
8.1	2 bits	Idle Increment Switch	968
8.3	2 bits	Idle Decrement Switch	967
8.5	2 bits	Engine Test Mode Switch	966
8.7	2 bits	Engine Shutdown Override Switch	1237

pgn65266 - Fuel Economy (Liquid) - LFE -

Transmission Repetition Rate:	100 ms
Data Length:	8 bytes
Data Page:	0
PDU Format:	254
PDU Specific:	242

Default Priority:		6	
Parameter Group Number:		65266 (00FEF2 ₁₆)	
Bit Start Position /Bytes	Length	SPN Description	SPN
1-2	2 bytes	Fuel Rate	183
3-4	2 bytes	Instantaneous Fuel Economy	184
5-6	2 bytes	Average Fuel Economy	185
7	1 byte	Throttle Position	51

pgn65267 - Vehicle Position - VP -

Transmission Repetition Rate:		5 s	
Data Length:		8 bytes	
Data Page:		0	
PDU Format:		254	
PDU Specific:		243	
Default Priority:		6	
Parameter Group Number:		65267 (00FEF3 ₁₆)	
Bit Start Position /Bytes	Length	SPN Description	SPN
1-4	4 bytes	Latitude	584
5-8	4 bytes	Longitude	585

pgn65268 - Tire Condition - TIRE -

Transmission Repetition Rate:		10 s	
Data Length:		8 bytes	
Data Page:		0	
PDU Format:		254	
PDU Specific:		244	
Default Priority:		6	
Parameter Group Number:		65268 (00FEF4 ₁₆)	
Bit Start Position /Bytes	Length	SPN Description	SPN
1	8 bits	Tire Location	929
2	1 byte	Tire Pressure	241
3-4	2 bytes	Tire Temperature	242
5.1	2 bits	CTI Wheel Sensor Status	1699
5.3	2 bits	CTI Tire Status	1698
5.5	2 bits	CTI Wheel End Electrical Fault	1697
6-7	2 bytes	Tire Air Leakage Rate	2586
8.6	3 bits	Tire Pressure Threshold Detection	2587

Tire Condition Message NOTE: Message has to repeated as necessary to transmit all available information. This method of location identification requires individual SPNs to be assigned to report failures specific to each individual component (I.e. each tire, each axle, etc.).

pgn65269 - Ambient Conditions - AMB -

Transmission Repetition Rate:		1 s	
Data Length:		8 bytes	
Data Page:		0	

PDU Format:	254		
PDU Specific:	245		
Default Priority:	6		
Parameter Group Number:	65269 (00FEF5 ₁₆)		
Bit Start Position /Bytes	Length	SPN Description	SPN
1	1 byte	Barometric Pressure	108
2-3	2 bytes	Cab Interior Temperature	170
4-5	2 bytes	Ambient Air Temperature	171
6	1 byte	Air Inlet Temperature	172
7-8	2 bytes	Road Surface Temperature	79

pgn65270 - Inlet/Exhaust Conditions 1 - ICI -

Transmission Repetition Rate:	0.5 s		
Data Length:	8 bytes		
Data Page:	0		
PDU Format:	254		
PDU Specific:	246		
Default Priority:	6		
Parameter Group Number:	65270 (00FEF6 ₁₆)		
Bit Start Position /Bytes	Length	SPN Description	SPN
1	1 byte	Particulate Trap Inlet Pressure	81
2	1 byte	Boost Pressure	102
3	1 byte	Intake Manifold 1 Temperature	105
4	1 byte	Air Inlet Pressure	106
5	1 byte	Air Filter 1 Differential Pressure	107
6-7	2 bytes	Exhaust Gas Temperature	173
8	1 byte	Coolant Filter Differential Pressure	112

pgn65271 - Vehicle Electrical Power - VEP -

Transmission Repetition Rate:	1 s		
Data Length:	8 bytes		
Data Page:	0		
PDU Format:	254		
PDU Specific:	247		
Default Priority:	6		
Parameter Group Number:	65271 (00FEF7 ₁₆)		
Bit Start Position /Bytes	Length	SPN Description	SPN
1	1 byte	Net Battery Current	114
2	1 byte	Alternator Current	115
3-4	2 bytes	Alternator Potential (Voltage)	167
5-6	2 bytes	Electrical Potential (Voltage)	168
7-8	2 bytes	Battery Potential (Voltage), Switched	158

pgn65272 - Transmission Fluids - TF -

Transmission Repetition Rate:	1 s		
-------------------------------	-----	--	--

Data Length:		8 bytes	
Data Page:		0	
PDU Format:		254	
PDU Specific:		248	
Default Priority:		6	
Parameter Group Number:		65272 (00FEF8 ₁₆)	
Bit Start Position /Bytes	Length	SPN Description	SPN
1	1 byte	Clutch Pressure	123
2	1 byte	Transmission Oil Level	124
3	1 byte	Transmission Filter Differential Pressure	126
4	1 byte	Transmission Oil Pressure	127
5-6	2 bytes	Transmission Oil Temperature	177

pgn65273 - Axle Information - AI -

Transmission Repetition Rate:		1 s	
Data Length:		8 bytes	
Data Page:		0	
PDU Format:		254	
PDU Specific:		249	
Default Priority:		6	
Parameter Group Number:		65273 (00FEF9 ₁₆)	
Bit Start Position /Bytes	Length	SPN Description	SPN
1	1 byte	Steering Axle Temperature	75
2	8 bits	Drive Axle Location	930
3	1 byte	Drive Axle Lift Air Pressure	579
4	1 byte	Drive Axle Temperature	578
5	1 byte	Drive Axle Lube Pressure	2613
8	1 byte	Steering Axle Lube Pressure	2614

Axle information message NOTE: Message must be repeated as necessary to transmit all available information. This method of location identification requires individual SPNs to be assigned to report failures specific to each individual component (I.e. each tire, each axle, etc.).

pgn65274 - Brakes - B -

Transmission Repetition Rate:		1 s	
Data Length:		8 bytes	
Data Page:		0	
PDU Format:		254	
PDU Specific:		250	
Default Priority:		6	
Parameter Group Number:		65274 (00FEFA ₁₆)	
Bit Start Position /Bytes	Length	SPN Description	SPN
1	1 byte	Brake Application Pressure	116
2	1 byte	Brake Primary Pressure	117
3	1 byte	Brake Secondary Pressure	118
4.1	2 bits	Parking Brake Actuator	619

pgn65275 - Retarder fluids - RF -

Transmission Repetition Rate:	1 s		
Data Length:	8 bytes		
Data Page:	0		
PDU Format:	254		
PDU Specific:	251		
Default Priority:	6		
Parameter Group Number:	65275 (00FEFB ₁₆)		
Bit Start Position /Bytes	Length	SPN Description	SPN
1	1 byte	Hydraulic Retarder Pressure	119
2	1 byte	Hydraulic Retarder Oil Temperature	120

pgn65276 - Dash Display - DD -

Transmission Repetition Rate:	1s		
Data Length:	8 bytes		
Data Page:	0		
PDU Format:	254		
PDU Specific:	252		
Default Priority:	6		
Parameter Group Number:	65276 (00FEFC ₁₆)		
Bit Start Position /Bytes	Length	SPN Description	SPN
1	1 byte	Washer Fluid Level	80
2	1 byte	Fuel Level	96
3	1 byte	Fuel Filter Differential Pressure	95
4	1 byte	Engine Oil Filter Differential Pressure	99
5-6	2 bytes	Cargo Ambient Temperature	169

pgn65277 - Alternate Fuel 1 - A1 -

Transmission Repetition Rate:	500 ms		
Data Length:	8 bytes		
Data Page:	0		
PDU Format:	254		
PDU Specific:	253		
Default Priority:	6		
Parameter Group Number:	65277 (00FEFD ₁₆)		
Bit Start Position /Bytes	Length	SPN Description	SPN
1	1 byte	Blower Bypass Valve Position	72
2-3	2 bytes	Gas Supply Pressure	159

pgn65278 - Auxiliary Water Pump Pressure - AWPP -

Transmission Repetition Rate:	1 s		
Data Length:	8 bytes		
Data Page:	0		
PDU Format:	254		

PDU Specific:		254	
Default Priority:		6	
Parameter Group Number:		65278 (00FEFE ₁₆)	
Bit Start Position /Bytes	Length	SPN Description	SPN
1	1 byte	Auxiliary Pump Pressure	73

pgn65279 - Water in Fuel Indicator - WFI -

Transmission Repetition Rate:		10 s	
Data Length:		8 bytes	
Data Page:		0	
PDU Format:		254	
PDU Specific:		255	
Default Priority:		6	
Parameter Group Number:		65279 (00FEFF ₁₆)	
Bit Start Position /Bytes	Length	SPN Description	SPN
1.1	2 bits	Water In Fuel Indicator	97

SAE J1939-71 Revised DEC2003

Rationale

The organization of this document has changed since the previous publication. All SAE J1939 parameters, parameter groups, and other items are captured in a database. The formatting of this version of SAE J1939-71 is a result of a database report output. Paragraph numbers have been removed and the parameters are listed in SPN order, while parameter groups are listed in PGN order.

New parameters and parameter groups are reviewed and discussed by the Subcommittee on a regular basis. This document reflects all changes and additions approved and balloted through December 2001.

Relationship of SAE Standard to ISO Standard

Not applicable.

Application

As described in the parent document, SAE J1939, there are a minimum of seven documents required to fully define a complete version of this network. This particular SAE Recommended Practice, SAE J1939-71, describes an Application Layer for vehicle use

Reference Section

SAE J1349—Engine Power Test Code—Spark Ignition and Compression Ignition—Net Power Rating

SAE J1843—Accelerator Pedal Position Sensor for Use with Electronic Controls in Medium- and Heavy-Duty Diesel On-Highway Engines

SAE J1922—Powertrain Control Interface for Electronic Controls Used in Medium and Heavy-Duty Diesel On-Highway Vehicle Applications

SAE J1939—Recommended Practice for a Serial Control and Communication Vehicle Network

SAE J1939-21—Data Link Layer

Developed by the SAE Truck and Bus Control and Communication Network Subcommittee

Sponsored by the Truck and Bus and Electrical/Electronics Committee