

Issued 1992-06  
Revised 2002-04

Superseding J1962 FEB1998

**(R) Diagnostic Connector**  
**Equivalent to ISO/DIS 15031-3:December 14, 2001**

**This document supersedes SAE J1962 FEB1998, and is technically equivalent to ISO/DIS 15031-3:December 14, 2001, except for minor reorganization of Paragraphs 1 and 2.**

**Foreword**—On-Board Diagnostic (OBD) regulations require passenger cars, and light and medium duty trucks, to be equipped with a standardised connector for purposes of access to on-board diagnostic information by “generic” test equipment. This document describes the requirements for the physical connection and associated pin usage to allow for standard access to the OBD data.

SAE J1962 was originally developed to meet U.S. OBD requirements for 1996 and later model year vehicles. ISO 15031-3 was based on SAE J1962 and was intended to meet European OBD requirements for 2000 and later model year vehicles, and added a modified connector type to accommodate vehicles with a 24 V system. This document is technically equivalent to ISO 15031-3 with U.S. specific requirements identified.

SAE Technical Standards Board Rules provide that: “This report is published by SAE to advance the state of technical and engineering sciences. The use of this report is entirely voluntary, and its applicability and suitability for any particular use, including any patent infringement arising therefrom, is the sole responsibility of the user.”

SAE reviews each technical report at least every five years at which time it may be reaffirmed, revised, or cancelled. SAE invites your written comments and suggestions.

Copyright ©2002 Society of Automotive Engineers, Inc.

All rights reserved. No part of this publication may be reproduced, stored in a retrieval system or transmitted, in any form or by any means, electronic, mechanical, photocopying, recording, or otherwise, without the prior written permission of SAE.

**TO PLACE A DOCUMENT ORDER:**

**Tel:** 877-606-7323 (inside USA and Canada)  
**Tel:** 724-776-4970 (outside USA)  
**Fax:** 724-776-0790  
**Email:** [custsvc@sae.org](mailto:custsvc@sae.org)  
**http://www.sae.org**

**SAE WEB ADDRESS:**

## TABLE OF CONTENTS

1.	Scope .....	3
1.1	Purpose .....	3
1.2	Differences from ISO Document .....	3
2.	References .....	4
2.1	Applicable Publications .....	4
2.1.1	SAE Publications .....	4
2.1.2	ISO Documents .....	4
2.2	Related Publications .....	4
2.2.1	SAE Publications .....	4
2.2.2	ISO Documents .....	4
3.	Terms and Definitions .....	5
4.	Vehicle Connector Location/Access .....	5
4.1	Consistency of Location .....	5
4.1.1	Location of Vehicle Connector Type A .....	5
4.1.2	Location of Vehicle Connector Type B .....	5
4.2	Ease of Access .....	5
4.3	Visibility .....	5
4.4	Vehicle Operation .....	5
5.	Vehicle and External Test Equipment Connector Design .....	6
5.1	Dimensions .....	6
5.2	Number of Contacts .....	6
5.3	Contact Requirements .....	6
5.3.1	Contact Types .....	6
5.3.2	Contact Spacing .....	6
5.4	Connector Mating .....	6
5.5	Connector Shape/Features .....	6
5.6	Spring Clip .....	6
5.7	Temperature Class .....	6
5.8	External Test Equipment Connector Cycle Life .....	6
5.9	Strain Relief .....	6
5.10	Contact and Connector Parameters and Performance Requirements .....	7
5.10.1	Preconditioning .....	7
5.10.2	Functional Parameters for Contacts .....	7
5.10.3	Performance Requirements for Contacts .....	7
5.10.4	Connector System Performance Requirements .....	7
5.10.5	Accelerated Environmental Exposures for the Vehicle Connector .....	7
6.	Contact Allocation and Specifications for Related Electrical Circuits .....	8
6.1	Vehicle and External Test Equipment Connector Contact Designation .....	8
6.2	General Contact Allocation .....	8
6.3	Vehicle Connector Contact Allocation .....	8
6.3.1	Vehicle Connector Contacts 1, 3, 8, 9, 11, 12, and 13 .....	8
6.3.2	Vehicle Connector Contact 2 .....	8
6.3.3	Vehicle Connector Contact 4 .....	8
6.3.4	Vehicle Connector Contact 5 .....	9
6.3.5	Vehicle Connector Contact 6 .....	9
6.3.6	Vehicle Connector Contact 7 .....	9
6.3.7	Vehicle Connector Contact 10 .....	9

SAE J1962 Revised APR2002

6.3.8	Vehicle Connector Contact 14 .....	9
6.3.9	Vehicle Connector Contact 15 .....	9
6.3.10	Vehicle Connector Contact 16 .....	10
6.4	Vehicle Connector Contact Protection .....	10
6.5	External Test Equipment Connector Contact Allocations and Requirements for Related Circuits .....	10
6.5.1	External Test Equipment Connector Contacts 1, 3, 8, 9, 11, 12, and 13.....	10
6.5.2	External Test Equipment Connector Contacts 2, 6, 7, 10, 14, and 15.....	10
6.5.3	External Test Equipment Connector Contact 4 .....	10
6.5.4	External Test Equipment Connector Contact 5 .....	10
6.5.5	External Test Equipment Connector Contact 16 .....	11
6.6	External Test Equipment Connector Contact Protection .....	11
6.7	Minimum Impedance between External Test Equipment Connector Contacts 4, 5, and the External Surface of External Test Equipment .....	11
7.	Notes .....	14
7.1	Marginal Indicia.....	14
Appendix A (normative)	Diagnostic Connection Type A .....	15
A.1	Vehicle Connector Type A.....	15
A.2	External Test Equipment Connector Type A .....	16
Appendix B (normative)	Diagnostic Connection Type B .....	17
B.1	Vehicle Connector Type B.....	17
B.2	External Test Equipment Connector Type B .....	18

**1. Scope**

**1.1 Purpose**—This document supersedes SAE J1962 FEB1998, and is technically equivalent to ISO/DIS 15031-3:December 14, 2001.

This document is intended to satisfy the requirements of an OBD connector as required by U.S. On-Board Diagnostic (OBD) regulations. The diagnostic connection specified in this document consists of two mating connectors, the vehicle connector and the external test equipment connector.

This document specifies:

- a. The functional requirements for the vehicle connector. These functional requirements are separated into four principal areas: connector location/access, connector design, connector contact allocation, and electrical requirements for connector and related electrical circuits,
- b. The functional requirements for the external test equipment connector. These functional requirements are separated into three principal areas: connector design, connector contact allocation, and electrical requirements for connector and related electrical circuits.

**1.2 Differences from ISO Document**—The ISO 15031-3 document is intended to satisfy the requirements of OBD requirements in countries other than the U.S., and includes functionality not required or not allowed in the U.S.

Notable exceptions are:

- a. Proposed U.S. OBD regulations specify a connector location that is more restrictive than specified in this document.
- b. Proposed U.S. OBD regulations do not allow greater than 20 V at the SAE J1962 connector. Only the Type A connector as defined in this document is allowable.

## SAE J1962 Revised APR2002

Differences between the documents are highlighted in the technical requirements sections of this document. Deleted text is highlighted with ~~strike through~~ and new text is highlighted with ***bold italic***.

**NOTE— To maintain equivalency of the documents, a comma is used as a decimal marker for numeric values in this document.**

### 2. References

**2.1 Applicable Publications**—The following publications form a part of this specification to the extent specified herein. Unless otherwise indicated, the latest version of SAE publications shall apply.

2.1.1 SAE PUBLICATIONS—Available from SAE, 400 Commonwealth Drive, Warrendale, PA 15096-0001.

SAE J1850 MAY2001—Class B Data Communication Network Interface  
SAE J1978—OBD II Scan Tool - Equivalent to ISO/DIS 15031-4:December 14, 2001

2.1.2 ISO DOCUMENTS—Available from ANSI, 25 West 43rd Street, New York, NY 10036-8002.

ISO 8092-2:2000—Road vehicles - Connections for on-board electrical wiring harnesses - Part 2: Definitions, test methods and general performance requirements.  
ISO 9141-2:1994—Road vehicles - Diagnostic systems - Part 2: CARB requirements for interchange of digital information.  
ISO 9141-2:1994/Amd.1:1996—Road vehicles - Diagnostic systems - Part 2: CARB requirements for interchange of digital information Amendment 1.  
ISO 14230-4:2000—Road vehicles - Keyword protocol 2000 for diagnostic systems - Part 4: Requirements for emission-related systems.  
ISO/DIS 15031-3:December 14, 2001—Road vehicles - Communication between vehicle and external test equipment for emissions-related diagnostics - Part 3: Diagnostic connector and related electrical circuits, specification and use  
ISO/DIS 15765-4:2001—Road vehicles – Diagnostics on Controller Area Network (CAN) – Part 4: Requirements for emissions-related systems  
ISO 16750-2—Road vehicles — Environmental conditions and testing for electrical and electronical equipment - Part 2: Electrical load.

**2.2 Related Publications**—The following publications are provided for information purposes only and are not a required part of this specification.

2.2.1 SAE PUBLICATIONS—Available from SAE, 400 Commonwealth Drive, Warrendale, PA 15096-0001.

SAE J1930—Electrical/Electronic Systems Diagnostic Terms, Definitions, Abbreviations, and Acronyms – Equivalent to ISO/TR 15031-2:April 30, 2002  
SAE J1979—E/E Diagnostic Test Modes - Equivalent to ISO/DIS 15031-5:April 30, 2002  
SAE J2012—Diagnostic Trouble Code Definitions - Equivalent to ISO/DIS 15031-6:April 30, 2002

2.2.2 ISO DOCUMENTS—Available from ANSI, 25 West 43rd Street, New York, NY 10036-8002.

ISO 6722-3:1993—Road vehicles - Unscreened low-tension cables - Part 3: Conductor sizes and dimensions for thick-wall insulated cables.  
ISO 6722-4:1993—Road vehicles - Unscreened low-tension cables - Part 4: Conductor sizes and dimensions for thin-wall insulated cables.  
ISO 8092-3:1996—Road vehicles - Connections for on-board electrical wiring harnesses - Part 3: Tabs for multi-pole connections; dimensions and specific requirements  
ISO 15031-1:2001—Road vehicles - Communication between vehicle and external test equipment for emissions-related diagnostics - Part 1: General information.

### 3. *Terms and Definitions*

3.1 **Connection**—Two mated connectors or contacts.

3.2 **Connector**—Assembly of contact and housing which terminates conductors for the purpose of providing connection and disconnection to a suitable mating connector.

3.3 **Contact**—Conductive element in a connector (including means for cable attachment) which mates with a corresponding element to provide an electrical path.

3.4 **Female Contact**—Electrical contact (including means for cable attachment) intended to make electrical engagement on its inner surface and to accept entry of a male contact thus forming an electrical connection. Examples: receptacle, sleeve.

3.5 **Male Contact**—Electrical contact (including means for cable attachment) intended to make electrical engagement on its outer surface and to enter a female contact thus forming an electrical connection. Examples: tab, pin, blade.

### 4. *Vehicle Connector Location/Access*

#### 4.1 **Consistency of Location**

**NOTE**— *Proposed U.S. OBD regulations specify a connector location that is more restrictive than specified in this document. Applicability of those regulations should be verified by the user of this document to ensure vehicle compliance with OBD regulations.*

4.1.1 **LOCATION OF VEHICLE CONNECTOR TYPE A**—If the vehicle connector type A is used, the connector shall be located in the passenger or driver's compartment in the area bounded by the driver's end of the instrument panel to 300 mm beyond the vehicle centerline, attached to the instrument panel and easy to access from the driver's seat. The preferred location is between the steering column and the vehicle centerline. The vehicle connector shall be mounted to facilitate mating and unmating.

4.1.2 **LOCATION OF VEHICLE CONNECTOR TYPE B**—If the vehicle connector type B is used, the connector shall be located in the passenger or driver's compartment in the area bounded by the driver's end of the instrument panel, including the outer side, and an imagined line 750 mm beyond the vehicle centerline. It shall be attached to the instrument panel and easy to access from the driver's seat *or* from the Co-drivers seat *or* from the outside. The vehicle connector shall be mounted to facilitate mating and unmating.

4.2 **Ease of Access**—Access to the vehicle connector shall not require a tool for the removal of an instrument panel cover, connector cover, or any barriers. The vehicle connector shall be fastened and located so as to permit a one-handed/blind insertion of the mating external test equipment connector. Figure 4 illustrates the diagnostic connector access area for mated connection in the vehicle.

4.3 **Visibility**—The vehicle connector shall be out of the occupant's (front and rear seat) normal line of sight but easily visible to a "crouched" technician.

4.4 **Vehicle Operation**—Attachment of any external test equipment to the vehicle connector shall not preclude normal physical and electrical operation of the vehicle.

## 5. *Vehicle and External Test Equipment Connector Design*

**5.1 Dimensions**—For basic dimensions of the vehicle and external test equipment connector see Figures 1 and 2. For the physical dimensions of the connector type A see Figures A1 and A2 and for the connector type B see Figures B1 and B2.

The connector type B of the external test equipment connector shall be mateable with the connector type A and type B of the vehicle connector and the compliance of the electrical, mechanical, and climatic performances of the connection shall be guaranteed. The connector type A of the external test equipment connector shall be mateable with the connector type A of the vehicle connector and the compliance of the electrical, mechanical, and climatic performances of the connection shall be guaranteed.

**5.2 Number of Contacts**—The vehicle and external test equipment connectors shall each be capable of accommodating 16 contacts.

### 5.3 Contact Requirements

5.3.1 CONTACT TYPES—The vehicle connector shall consist of female contacts that will mate with the male blade contacts of the external test equipment connector.

5.3.2 CONTACT SPACING—Contact spacing is shown in Figures A1, A2, B1, and B2.

**5.4 Connector Mating**—The external test equipment connector contact mating shall be designed so that the signal ground and the chassis ground contacts of the external test equipment connector will make electrical contact prior to any other test equipment connector contacts making electrical contact. On the disconnect cycle, these same two contacts will not lose electrical contact until all of the other contacts have been disconnected.

**5.5 Connector Shape/Features**—The mating portions of both connectors shall be «D» shaped. The connectors shall have easily discernible polarisation features to allow for easy connection in a one-handed / blind operation.

The vehicle connector and the external test equipment connector shall have latching features that assure the external test equipment connector will remain mated when properly connected. The latching feature shall be designed to provide a positive feel when the external test equipment connector is fully seated. The latching feature shall not require the activation of any levers on either connector to mate or unmate. Pulling on the external test equipment connector in the disconnecting direction to separate the two mated connectors shall not result in any damage to either connector.

**5.6 Spring Clip**—An optional spring clip (as specified in Figure 1) may be used on the external test equipment connector.

**5.7 Temperature Class**—The minimum temperature range for the selected material shall be in accordance with the class 2 of the environmental temperature range specified in table 3 of ISO 8092-2 (–40 °C to +85 °C).

**5.8 External Test Equipment Connector Cycle Life**—The external test equipment manufacturer shall specify the minimum number of mating cycles the external test equipment connector is capable of while meeting the requirements.

**5.9 Strain relief**—The external test equipment connector shall have strain relief features for the cable connected to it.

## 5.10 Contact and Connector Parameters and Performance Requirements

- 5.10.1 PRECONDITIONING—Take unused samples and perform 200 mating cycles before the test in 5.10.5 and the requirements in 5.10.3 and 5.10.4.
- 5.10.2 FUNCTIONAL PARAMETERS FOR CONTACTS
- Blade size for external test equipment connector: Shall conform to the dimensions shown in Figure 2.
  - Minimum Current - carrying capacity for contacts: 10 A, DC at 20 °C
  - Temperature range according to class 2 of the environmental temperature range in table 3 of ISO 8092-2: -40 °C to +85 °C
  - Voltage range in accordance with ISO 16750-2: **-0.05 to 30.0 V DC**.
  - The contact system shall accept cross-sectional area of cable conductors of up to: 0,75 mm<sup>2</sup> and 18 AWG.
- 5.10.3 PERFORMANCE REQUIREMENTS FOR CONTACTS—The contact system (i.e. mated contact pairs) shall meet the performance requirements in a) and b) below following each of the environmental exposures listed in the 5.10.5. Tests of connection resistance are to be taken as specified in 4.8.1.1 of ISO 8092-2.
- Resistance interface (measured at 1 A): 3 mΩ maximum
  - Recommended resistance cable to cable per contact pair: 10 mΩ at initial mating when tested with a constant current source of 1 A according to ISO 8092-2, clause 4.8.1.3.
  - Recommended connection resistance at low current: 100 mΩ at initial mating when tested with a constant current source of 100 μA **at 20 mV** according to ISO 8092-2, clause 4.8.1.2.
- 5.10.4 CONNECTOR SYSTEM PERFORMANCE REQUIREMENTS—The connector system shall meet the performance requirements outlined in a) through e) below following each of the environmental exposures listed in 5.10.5. Measurements shall be taken at room temperature (23 °C ± 5 °C).
- Insulation resistance between adjacent contacts tested as in 4.12 of ISO 8092-2: 20 MΩ minimum.
  - Contact retention in housing tested as in 4.7.1 of ISO 8092-2: 80 N minimum.
  - Connection and disconnection force tested as in 4.3.1 of ISO 8092-2 fully equipped with 16 contact pairs: 88 N maximum.
  - Connector mating force with 16 contact pairs:
    - without spring clip: 110 N maximum,
    - with spring clip: 142 N maximum (see Figure 1).
  - Polarisation feature shall prevent mismatching of connectors when a force of 300 N is applied.
  - Mounting Feature: The vehicle connector mounting feature shall withstand a force of 300 N applied to the connector mating area in the direction of the connecting and disconnecting process without mechanical and electrical problems.
- 5.10.5 ACCELERATED ENVIRONMENTAL EXPOSURES FOR THE VEHICLE CONNECTOR—Accelerated environmental testing shall be conducted for the vehicle connector while not being mated to the external test equipment connector. Perform each environmental exposure a) through d) with separate sample groups. After exposure, the vehicle connector shall be mated to original external test equipment connector for the performance tests in 5.10.3 and 5.10.4.
- Thermal Cycling: Subject the sample to 1000 cycles as follows (see 4.22 of ISO 8092-2):
    - 30 min at a temperature of -40 °C ± 2 °C;
    - 10 s max. transition time;
    - 30 min at a temperature of 110 °C ± 2 °C;
    - 10 s max. transition time.

- b. Temperature/humidity cycling: Subject the sample to 15 cycles as follows (see 4.10 of ISO 8092-2):
- Hold the chamber temperature at  $t_c = 23\text{ °C} \pm 5\text{ °C}$  and at 45 to 75% RH (relative humidity) for 4 h;
  - Raise  $t_c$  to  $55\text{ °C} \pm 2\text{ °C}$  at 95 to 99 % RH within 0,5 h;
  - Hold  $t_c$  at  $55\text{ °C} \pm 2\text{ °C}$  at 95 to 99 % RH for 10 h;
  - Lower  $t_c$  to  $-40\text{ °C} \pm 2\text{ °C}$  within 2.5 h (During these periods the relative humidity is uncontrolled.);
  - Hold  $t_c$  at  $-40\text{ °C} \pm 2\text{ °C}$  for 2 h (During these periods the relative humidity is uncontrolled.);
  - Raise  $t_c$  to  $85\text{ °C} \pm 2\text{ °C}$  within 1,5 h from  $-40\text{ °C} \pm 2\text{ °C}$  (During these periods the relative humidity is uncontrolled.);
  - Hold  $t_c$  at  $85\text{ °C} \pm 2\text{ °C}$  for 2 h (During these periods the relative humidity is uncontrolled.);
  - Allow to return to room temperature of  $23\text{ °C} \pm 5\text{ °C}$  within 1,5 h (During these periods the relative humidity is uncontrolled.).

Alternative test for temperature/humidity cycling — 15 cycles of the following:

- 16 hours at 95 % RH and 40 °C,
- 2 hours at  $-40\text{ °C}$ ,
- 2 hours at  $+85\text{ °C}$ ,
- 4 hours at room temperature.

- c. Mechanical Shock: 3 shocks at 50 g in each of the 3 mutually perpendicular axes of the connector.  
d. Vibration: Sinusoidal 1,5 mm  $\pm$  0,15 mm amplitude by 15 g for 2 hours in each of the 3 mutually perpendicular axes at room temperature.

## **6. Contact Allocation and Specifications for Related Electrical Circuits**

**6.1 Vehicle and External Test Equipment Connector Contact Designation**—See Figure 3 and Table 1 for vehicle connector and external test equipment connector contact designations.

**6.2 General Contact Allocation**—See Table 1 for a summary of contact allocations.

### **6.3 Vehicle Connector Contact Allocation**

**6.3.1 VEHICLE CONNECTOR CONTACTS 1, 3, 8, 9, 11, 12, AND 13**—Allocation of vehicle connector contacts 1, 3, 8, 9, 11, 12, and 13 is left to the discretion of the vehicle manufacturer.

**6.3.2 VEHICLE CONNECTOR CONTACT 2**—If SAE J1850 10,4 VPW (Variable Pulse Width) is used in a vehicle to supply OBD required communication services, then contact 2 of the vehicle connector shall be the SAE J1850 10,4 VPW (Variable Pulse Width) signal connection.

If SAE J1850 41,6 PWM (Pulse Width Modulation) is used in a vehicle to supply OBD required communication services, then contact 2 of the vehicle connector shall be the bus positive signal of the SAE J1850 41,6 PWM (Pulse Width Modulation) connection.

If neither SAE J1850 10,4 VPW (Variable Pulse Width) nor SAE J1850 41,6 PWM (Pulse Width Modulation) is used in a vehicle to supply OBD (on-board diagnosis) required communication services, then assignment of this contact is left to the discretion of the vehicle manufacturer, provided this assignment does not interfere with the operation of, nor cause damage to, tools conforming to SAE J1978.

**6.3.3 VEHICLE CONNECTOR CONTACT 4**—Vehicle connector contact 4 is designated chassis ground and shall be connected electrically to the vehicle chassis in such a way as to provide power ground for external test equipment taking current as in SAE J1978.

NOTE— Section 6.5.3 External Test Equipment Connector Contact 4 specifies the use of this contact.



## SAE J1962 Revised APR2002

- 6.3.4 VEHICLE CONNECTOR CONTACT 5—Vehicle connector contact 5 is designated signal ground and shall be implemented in the vehicle connector in such a way as to provide a ground reference for the communication transceivers in external test equipment and as a possible power ground for test equipment taking current as in SAE J1978.

Its implementation in the vehicle shall take into consideration noise contributions and node-to-node voltage offset limitations of the OBD communication interface used in the vehicle. The use of a battery minus (-), common vehicle clean signal ground, «clean», «logic», or other connection points within a vehicle that minimise node-to-node voltage offsets and noise is recommended.

NOTE— Section 6.5.4 External Test Equipment Connector Contact 5 specifies the use of this contact.

- 6.3.5 VEHICLE CONNECTOR CONTACT 6—If ISO 15765-4 CAN is used in a vehicle to supply OBD required communication services, then contact 6 of the vehicle connector shall be the CAN-High bus signal connection.

If ISO 15765-4 is not used in a vehicle to supply OBD required communication services, then assignment of this contact is left to the discretion of the vehicle manufacturer, provided this assignment does not interfere with the operation of, nor cause damage to, tools conforming to SAE J1978.

- 6.3.6 VEHICLE CONNECTOR CONTACT 7—If a two wire or a one wire ISO 9141-2 or ISO 14230-4 interface is used in a vehicle to supply OBD required communication services, then contact 7 of the vehicle connector shall be the K line of the ISO 9141-2 or ISO 14230-4 interface.

If neither a two wire nor a one wire ISO 9141-2 or ISO 14230-4 interface is used in a vehicle to supply OBD required communication services, then assignment of this contact is left to the discretion of the vehicle manufacturer, provided this assignment does not interfere with the operation of, nor cause damage to, tools conforming to SAE J1978.

- 6.3.7 VEHICLE CONNECTOR CONTACT 10—If an SAE J1850 41,6 PWM (Pulse Width Modulation) interface is used in a vehicle to supply OBD required communication services, then contact 10 of the vehicle connector shall be the bus negative signal of the SAE J1850 41,6 PWM (Pulse Width Modulation) interface.

If an SAE J1850 41,6 PWM (Pulse Width Modulation) interface is not used in a vehicle to supply OBD required communication services, then assignment of this contact is left to the discretion of the vehicle manufacturer, provided this assignment does not interfere with the operation of, nor cause damage to, tools conforming to SAE J1978.

- 6.3.8 VEHICLE CONNECTOR CONTACT 14—If ISO 15765-4 CAN is used in a vehicle to supply OBD required communication services, then contact 14 of the vehicle connector shall be the CAN-Low bus signal connection.

If ISO 15765-4 is not used in a vehicle to supply OBD required communication services, then assignment of this contact is left to the discretion of the vehicle manufacturer, provided this assignment does not interfere with the operation of, nor cause damage to, tools conforming to SAE J1978.

- 6.3.9 VEHICLE CONNECTOR CONTACT 15—If a two wire ISO 9141-2 or ISO 14230-4 interface is used in a vehicle to supply OBD required communication services, then contact 15 of the vehicle connector shall be the L line of the ISO 9141-2 or ISO 14230-4 interface.

If a two wire ISO 9141-2 or ISO 14230-4 interface is not used in a vehicle to supply OBD required communication services, then assignment of this contact is left to the discretion of the vehicle manufacturer, provided this assignment does not interfere with the operation of, nor cause damage to, tools conforming to SAE J1978.

6.3.10 VEHICLE CONNECTOR CONTACT 16—Vehicle connector contact 16 is designated to provide permanent positive voltage for the external test equipment, both for power and also as a reference for K-Line communications. It is recommended that this connection is protected by the use of a fuse or other circuit protection element. This circuit may be grouped with other circuits.

The following shall apply:

- a. For the usage of connector type A according to Appendix A the nominal supply voltage at contact 16 shall be 12 V DC and the current supply supported shall be at a minimum of 4,0 A,
- b. For the usage of connector type B according to Appendix B the nominal supply voltage at contact 16 shall be 24 V DC and the current supply supported shall be at a minimum of 2,0 A,

6.4 **Vehicle Connector Contact Protection**—It is recommended that the vehicle manufacturer provides circuit protection in the event that the contacts of the vehicle connector are shorted together. This protection is limited to the ranges of voltages present at the vehicle connector before the external test equipment connector is mated to it.

#### 6.5 External Test Equipment Connector Contact Allocations and Requirements for Related Circuits

6.5.1 EXTERNAL TEST EQUIPMENT CONNECTOR CONTACTS 1, 3, 8, 9, 11, 12, AND 13—The use of external test equipment connector contacts 1, 3, 8, 9, 11, 12, and 13 is left to the discretion of the test equipment manufacturer.

The external test equipment connector contacts, seen from the point of connection to the vehicle, shall normally be in a high impedance state, that is at greater than 500 k $\Omega$  impedance relative to signal ground and at greater than 500 k $\Omega$  impedance relative to chassis ground.

Before the condition of these external test equipment connector contacts is changed from this high impedance state, the external test equipment user and/or the external test equipment shall verify the proper usage of these vehicle connector contacts.

6.5.2 EXTERNAL TEST EQUIPMENT CONNECTOR CONTACTS 2, 6, 7, 10, 14, AND 15—Assignment and use of external test equipment connector contacts 2, 6, 7, 10, 14, and 15 shall be compatible with the assignment and use of their mating contact in the vehicle connector (see paragraph 6.3).

6.5.3 EXTERNAL TEST EQUIPMENT CONNECTOR CONTACT 4—External test equipment connector contact 4 is designated chassis ground. This contact may be used by the external test equipment as a power ground. Implementation of this contact in the external test equipment connector is optional.

6.5.4 EXTERNAL TEST EQUIPMENT CONNECTOR CONTACT 5—External test equipment connector contact 5 is designated signal ground. This contact shall be used by the SAE J1978 external test equipment as the signal ground reference for vehicle communication transceivers.

External test equipment shall not draw more than 1,5 A through this contact.

NOTE— The 1,5 A limit refers to the use of the external test equipment covered by this document (e.g., support of the requirements of SAE J1978)

Support of other uses of the SAE J1962 connectors (e.g., shorting a manufacturer discretionary contact to ground) is not covered by this limitation.

6.5.5 EXTERNAL TEST EQUIPMENT CONNECTOR CONTACT 16—External test equipment connector contact 16 is designated as permanent positive voltage and is available to supply operating power and a reference voltage to the external test equipment.

6.6 External Test Equipment Connector Contact Protection—It is recommended that all circuits connected to the contacts of the external test equipment connector be protected to the extent that no damage will come to these circuits if any contact of the external test equipment connector:

- a. Is connected to vehicle connector contact 16 - as permanent positive voltage for up to 10 A;
- b. Is connected to vehicle connector contact 4 - vehicle chassis ground, or
- c. Is connected to vehicle connector contact 5 - vehicle signal ground.

6.7 Minimum Impedance between External Test Equipment Connector Contacts 4, 5, and the External Surface of External Test Equipment—The minimum impedance shall be 1 MΩ between each of the following:

- External test equipment connector contacts 4 and 5,
- External test equipment connector contact 4 and the external surface of the external test equipment,
- External test equipment connector contact 5 and the external surface of the external test equipment.

Dimensions in millimetres

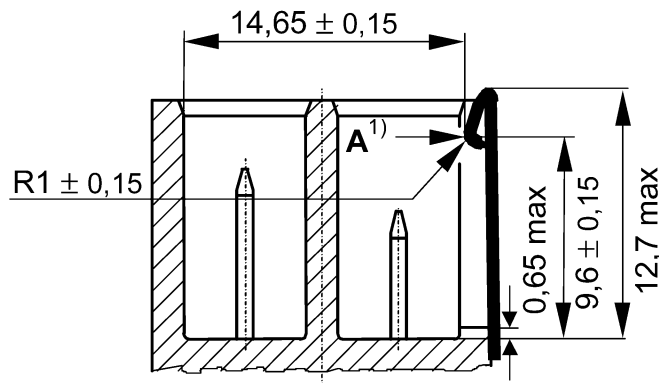

1) A force applied as shown by arrow "A" shall deflect clip outward for a distance of  $2,5 \pm 0,15$ , clip shall recover to original position. Connector shall meet specifications in 5.10.4.c), with spring clip in place.

FIGURE 1—SPRING CLIP DETAIL (OPTIONAL)

Dimensions in millimetres

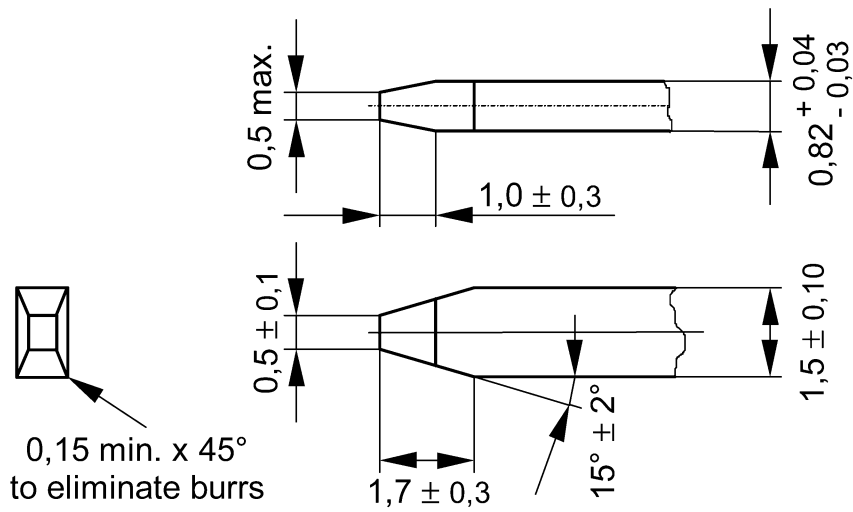

Dimensions of the 1,5 x 0,8 blade according to ISO 8092-3 are also acceptable.

FIGURE 2—BLADE DETAIL

1	2	3	4	5	6	7	8
9	10	11	12	13	14	15	16

FIGURE 3—CONTACT DESIGNATION FOR VEHICLE CONNECTOR MATING END VIEW

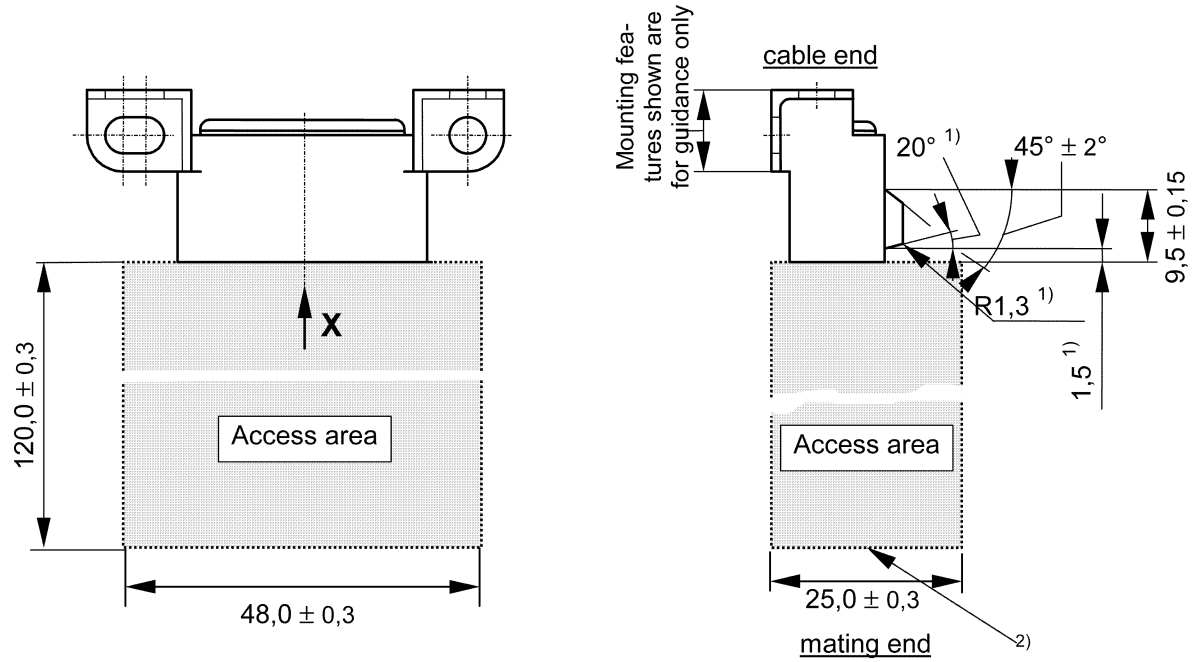

1) Nominal values.

2) Access to mating end to be clear in this area for the connecting external test equipment connector.

FIGURE 4—VEHICLE DIAGNOSTIC CONNECTOR ACCESS AREA

TABLE 1—GENERAL CONTACT ALLOCATIONS

Contact	General allocation
1	Discretionary <sup>1)</sup>
2	Bus positive line of SAE J1850 <sup>2)</sup>
3	Discretionary <sup>1)</sup>
4	Chassis ground
5	Signal ground
6	CAN_H line of ISO 15765-4 <sup>2)</sup>
7	K line of ISO 9141-2 and ISO 14230-4 <sup>2)</sup>
8	Discretionary <sup>1)</sup>
9	Discretionary <sup>1)</sup>
10	Bus negative line of SAE J1850 <sup>2)</sup>
11	Discretionary <sup>1)</sup>
12	Discretionary <sup>1)</sup>
13	Discretionary <sup>1)</sup>
14	CAN_L line of ISO 15765-4 <sup>2)</sup>
15	L line of ISO 9141-2 and ISO 14230-4 <sup>2)</sup>
16	Permanent positive voltage
<p><sup>1)</sup> Assignment of contacts 1, 3, 8, 9, 11, 12 and 13 in the vehicle connector is left to the discretion of the vehicle manufacturer.</p> <p><sup>2)</sup> Note, for contacts 2, 6, 7, 10, 14 and 15 the related diagnostic communication assignments are shown. These contacts may also be used for alternate assignments in the vehicle connector. See section 6.3 Vehicle connector contact allocation, and section 6.5 External test equipment connector contact allocations and requirements for related circuits, for further information.</p>	

## 7. Notes

- 7.1 Marginal Indicia**—*Many editorial changes and document organizational changes have been included in this document to be consistent with the equivalent ISO document, but do not affect the technical content of the document.* The change bar (I) located in the left margin is for the convenience of the user in locating areas where *technical* revisions have been made to the previous issue of the report. An (R) symbol to the left of the document title indicates a complete revision of the report.

APPENDIX A

(NORMATIVE)  
DIAGNOSTIC CONNECTION TYPE A

A.1 *Vehicle Connector Type A*—The following figure specifies the vehicle connector.

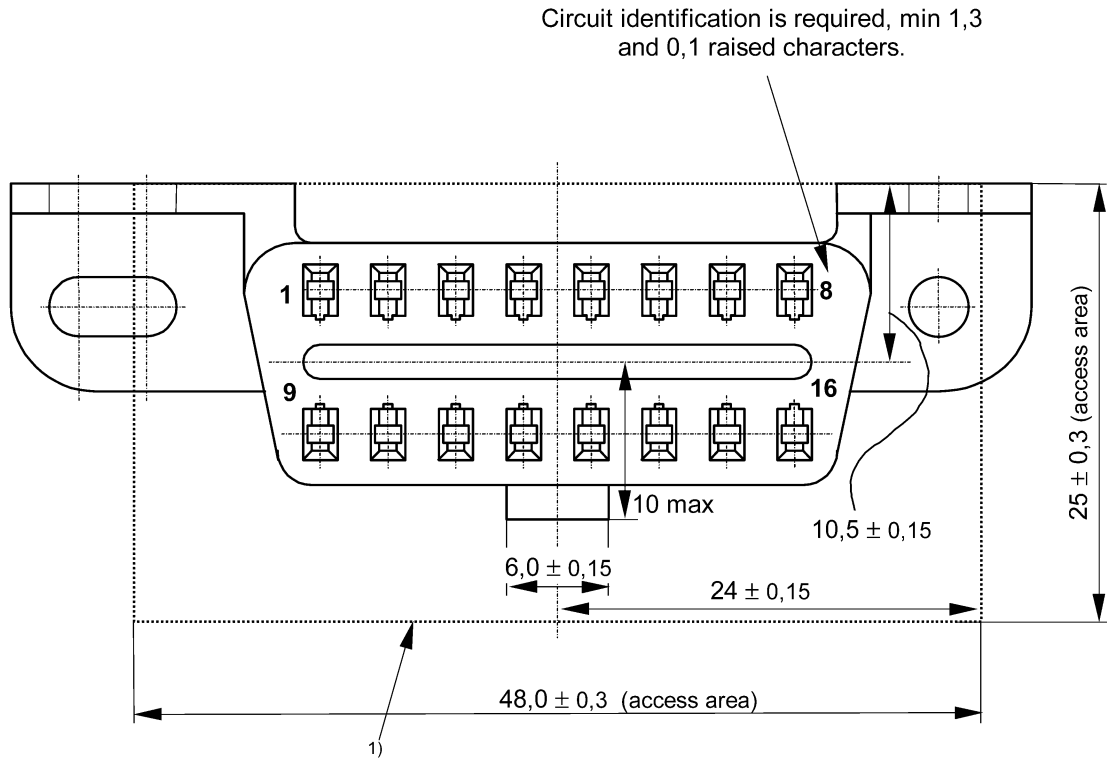

1) Access to mating end to be clear in this area for the connecting external test equipment connector.

FIGURE A1—VEHICLE CONNECTOR TYPE A

**A.2 External Test Equipment Connector Type A**—The following figures specify the external test equipment connector.

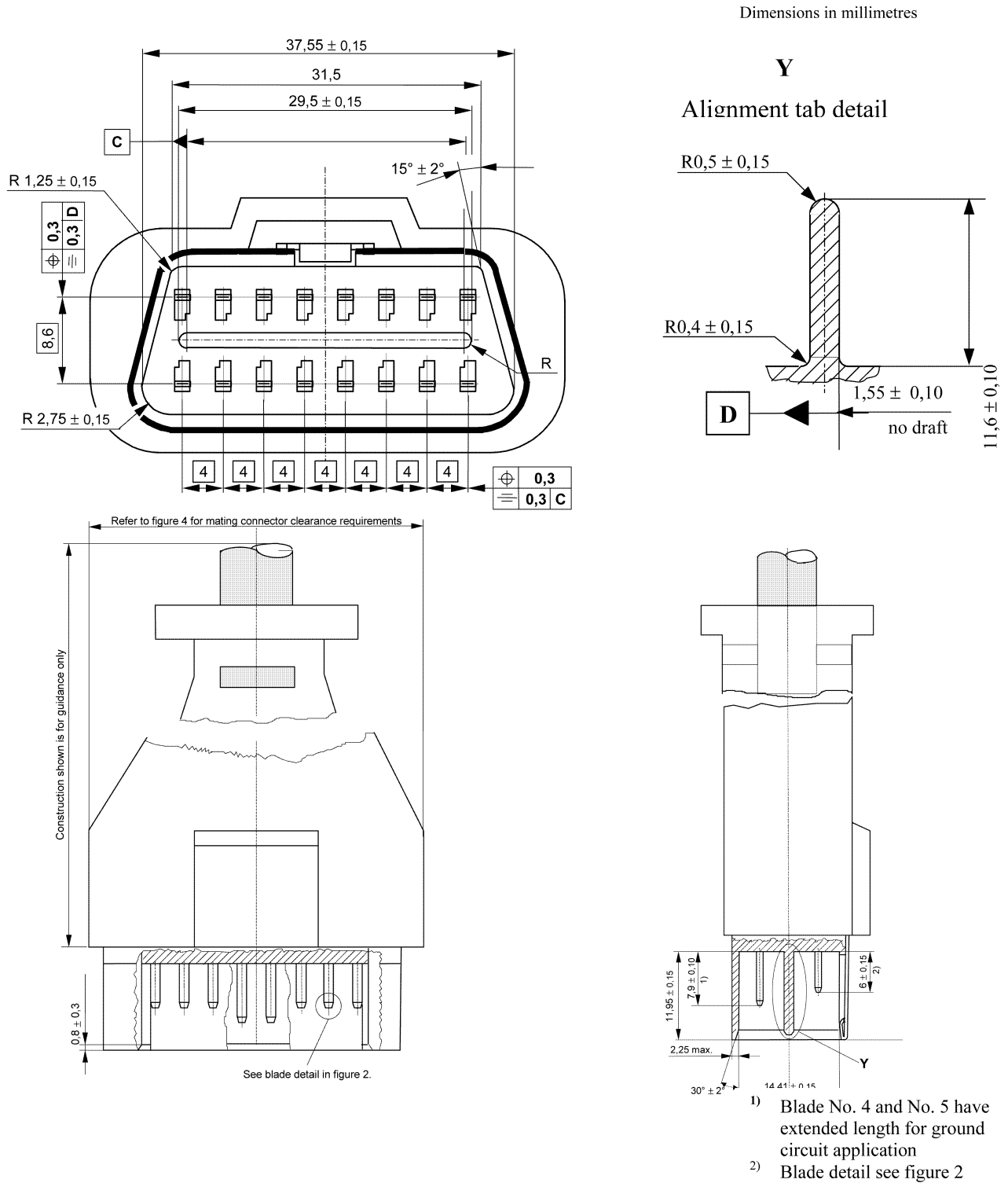

- 1) Blade No. 4 and No. 5 have extended length for ground circuit application
- 2) Blade detail see figure 2

FIGURE A2—EXTERNAL TEST EQUIPMENT CONNECTOR TYPE A



APPENDIX B  
(NORMATIVE)  
DIAGNOSTIC CONNECTION TYPE B

B.1 Vehicle Connector Type B

**NOTE—** Proposed U.S. OBD regulations do not allow greater than 20 V at the vehicle connector, therefore, this connector type may not be allowed for compliance with U.S. OBD regulations.

The following figure specifies the vehicle connector.

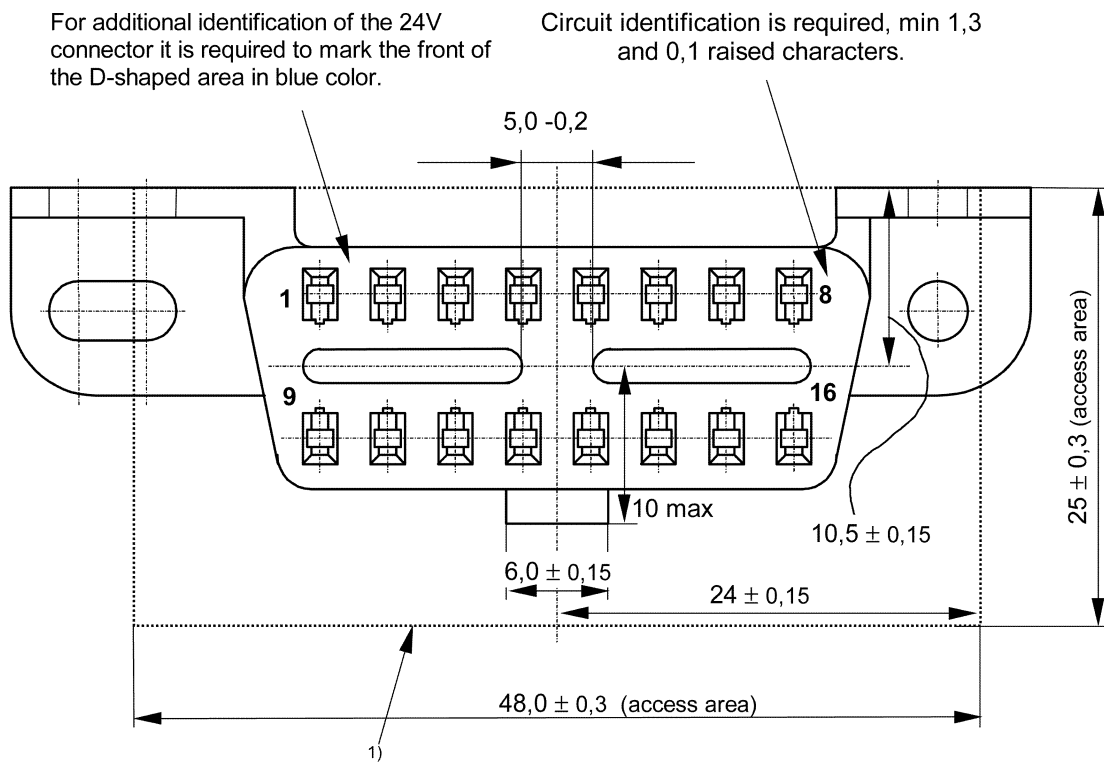

1) Access to mating end to be clear in this area for the connecting external test equipment connector.

FIGURE B1—VEHICLE CONNECTOR TYPE B

**B.2 External Test Equipment Connector Type B**—The following figures specify the external test equipment connector.

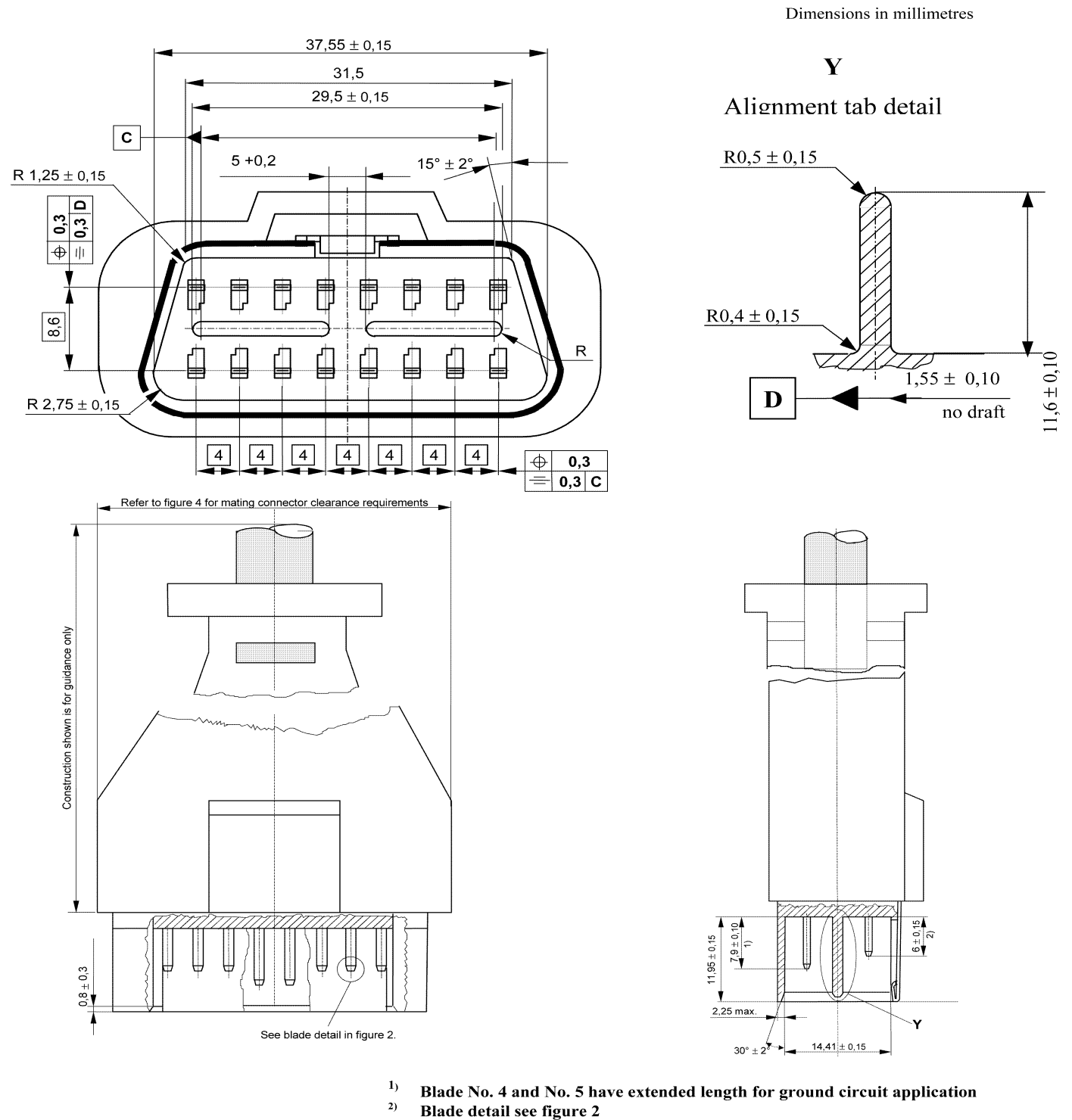

FIGURE B2—EXTERNAL TEST EQUIPMENT CONNECTOR TYPE B

## SAE J1962 Revised APR2002

**Rationale**—ISO 15031-3 was created to be referenced in OBD regulations outside of the United States, and contains the same technical content as the previous version of SAE J1962 with the following additions:

- a. Provisions for ISO 15765-4 (CAN) as a diagnostic serial data link (only 500 Kbps is allowed in U.S. regulations.)
- b. Allowance for 24 VDC connector as defined in ISO 15031-3 (not allowed in U.S. regulations).

This document was issued to include the same technical content, in the same order, and with the same section references as the ISO document, but includes exceptions required by proposed U.S. regulations.

**Relationship of SAE Standard to ISO Standard**—This document is technically equivalent to ISO 15031-3 with U.S. specific requirements identified.

**Application**—This document is intended to satisfy the requirements of an OBD connector as required by U.S. On-Board Diagnostic (OBD) regulations. The diagnostic connection specified in this document consists of two mating connectors, the vehicle connector and the external test equipment connector.

This document specifies:

- a. the functional requirements for the vehicle connector. These functional requirements are separated into four principal areas: connector location/access, connector design, connector contact allocation, and electrical requirements for connector and related electrical circuits,
- b. the functional requirements for the external test equipment connector. These functional requirements are separated into three principal areas: connector design, connector contact allocation, and electrical requirements for connector and related electrical circuits.

### Reference Section

SAE J1850 MAY2001—Class B Data Communication Network Interface

SAE J1930—Electrical/Electronic Systems Diagnostic Terms, Definitions, Abbreviations, and Acronyms  
– Equivalent to ISO/TR 15031-2:April 30, 2002

SAE J1978—OBD II Scan Tool - Equivalent to ISO/DIS 15031-4:December 14, 2001

SAE J1979—E/E Diagnostic Test Modes - Equivalent to ISO/DIS 15031-5:April 30, 2002

SAE J2012—Diagnostic Trouble Code Definitions - Equivalent to ISO/DIS 15031-6:April 30, 2002

ISO 6722-3:1993—Road vehicles - Unscreened low-tension cables - Part 3: Conductor sizes and dimensions for thick-wall insulated cables

ISO 6722-4:1993—Road vehicles - Unscreened low-tension cables - Part 4: Conductor sizes and dimensions for thin-wall insulated cables

ISO 8092-3:1996—Road vehicles - Connections for on-board electrical wiring harnesses - Part 3: Tabs for multi-pole connections; dimensions and specific requirements

ISO 8092-2:2000—Road vehicles - Connections for on-board electrical wiring harnesses - Part 2: Definitions, test methods and general performance requirements.

ISO 9141-2:1994—Road vehicles - Diagnostic systems - Part 2: CARB requirements for interchange of digital information

**SAE J1962 Revised APR2002**

ISO 9141-2:1994/Amd.1:1996—Road vehicles - Diagnostic systems - Part 2: CARB requirements for interchange of digital information Amendment 1

ISO 14230-4:2000—Road vehicles - Keyword protocol 2000 for diagnostic systems - Part 4: Requirements for emission-related systems

ISO 15031-1:2001—Road vehicles - Communication between vehicle and external test equipment for emissions-related diagnostics - Part 1: General information

ISO/DIS 15031-3:December 14, 2001—Road vehicles - Communication between vehicle and external test equipment for emissions-related diagnostics - Part 3: Diagnostic connector and related electrical circuits, specification and use

ISO/DIS 15765-4:2001—Road vehicles – Diagnostics on Controller Area Network (CAN) – Part 4: Requirements for emissions-related systems

ISO 16750-2—Road vehicles — Environmental conditions and testing for electrical and electronical equipment - Part 2: Electrical load

**Developed by the SAE Vehicle Electrical and Electronics Diagnostic Systems Standards Committee**